

INSTALLATION INSTRUCTIONS

PRODUCT: LOKI

CONFIGURATION: BYPASS DOORS

TROLLEY: TOP MOUNT

TRACK MOUNT: WALL

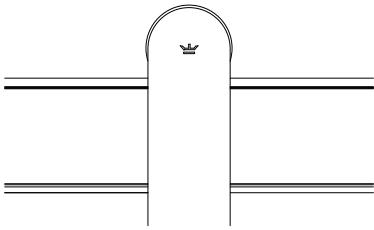

The corresponding Product Specification document is to be comprehensively reviewed prior to product installation takes place.

To deviate, or to not comprehensively and precisely follow all applicable product specifications and installation instructions can result in unsafe or hazardous site conditions that can cause bodily harm or death.

Krownlab products are covered by U.S. patents and trademarks. For more information visit www.krownlab.com

2024-02-20

I. TOOLS + MATERIALS REQUIRED

TOOLS

- Tape measure
- Level
- Stud finder
- Ratchet and Imperial socket set
- Torque wrench capable of measuring up to 110 inch-lbs (9.5 ft-lbs)
- Imperial Allen wrench and bit set
- Standard bit kit with driver
- Power drill
- Imperial drill bit index and countersink bit
- 1-3/4" Forstner drill bit, or similar (for drywall)
- Router with grooving bit (for orders including wood door panels only)

TOOLS FOR DRILLING AND CUTTING TRACK

- Miter or chop saw and carbide toothed blade
- 9/16" metal drill bit

MATERIALS

- Blue painters tape
- Pencil or other non permanent marking tool

2. VERIFY ALL COMPONENTS

BASE KIT

Quantity included of each item is specific to ordered product configuration.

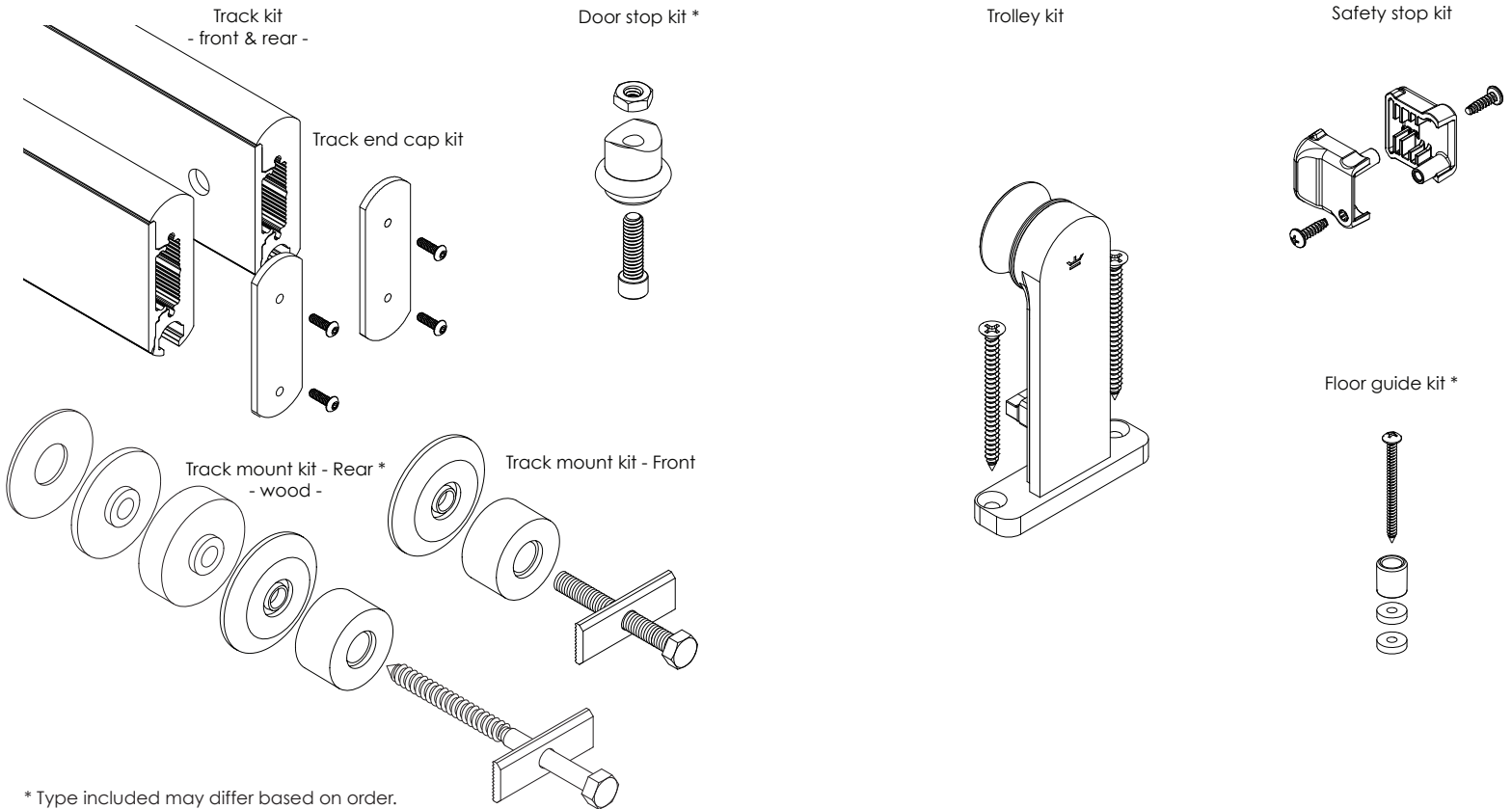

SYSTEM OPTIONS AND ADDITIONS

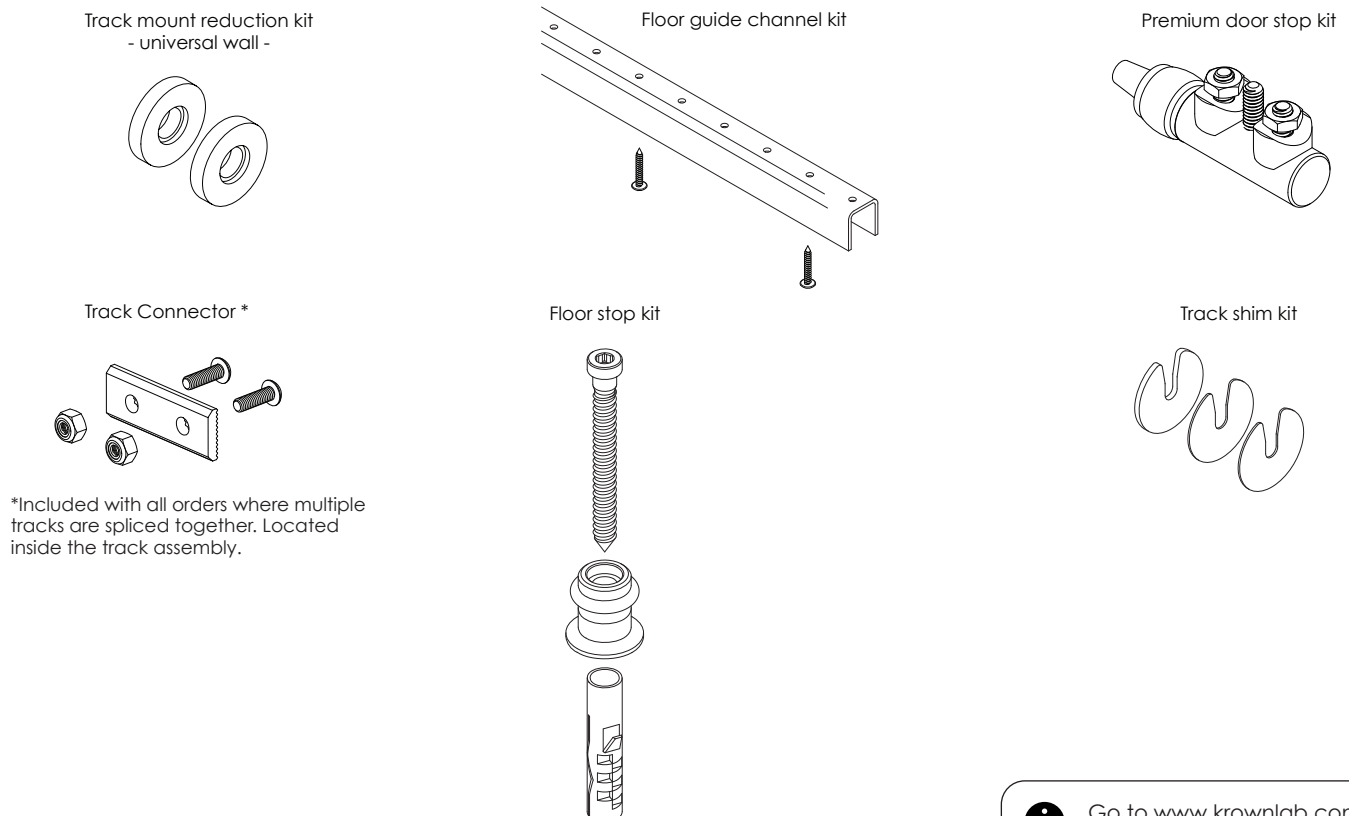

Go to www.krownlab.com for our complete product range.

3. REMOVE TRACK COVERS

- ① Remove the tracks from the protective sleeve and gently pry the covers from the bases with a slender plastic (non-marring) tool.
- ② If your order contains multiple tracks to be spliced together, remove the Track Connector located inside the track cavity.

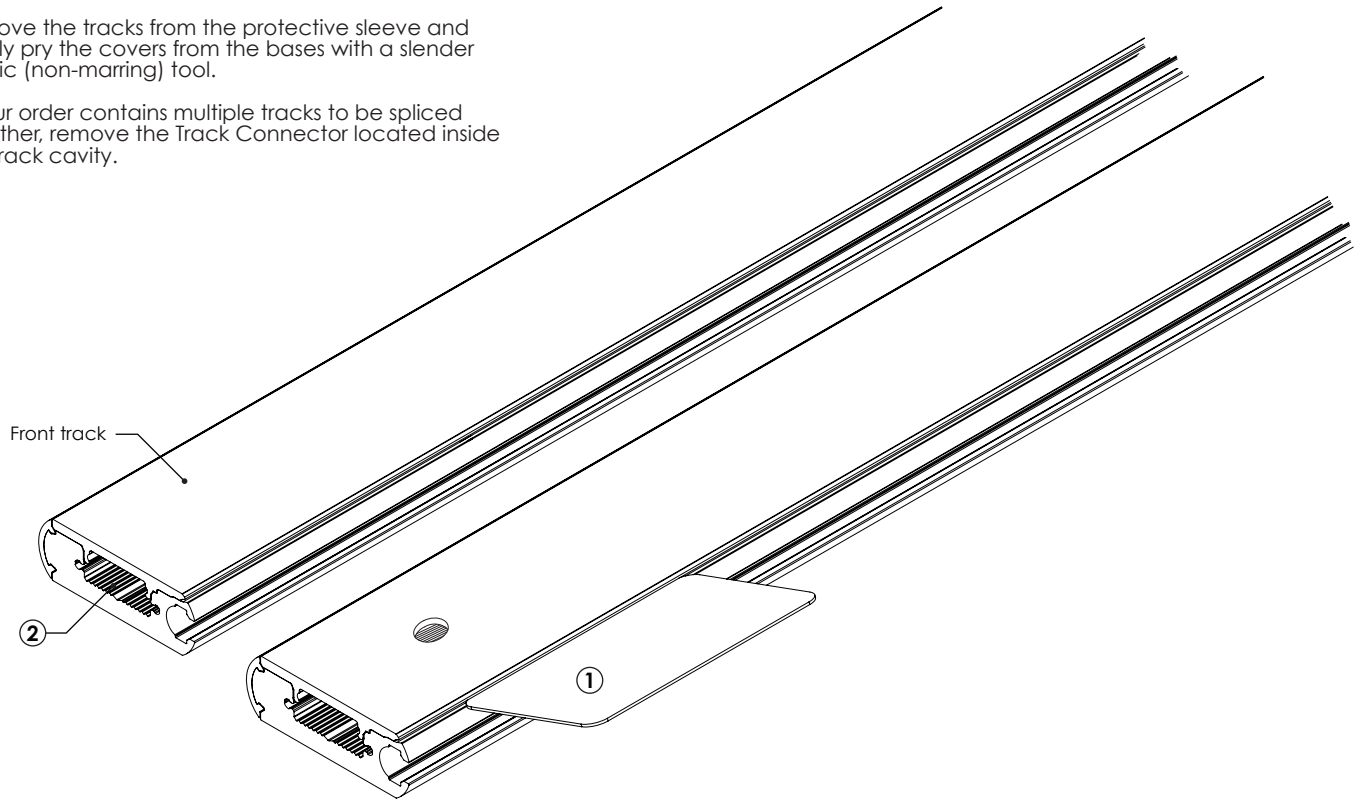

4. LOCATE REAR TRACK ATTACHMENT POINTS

- ① Determine the height of the track centerline:

$$\text{HEIGHT} = \text{DOOR PANEL HEIGHT} + 3''$$

This will result in approximately 3/8" of clearance between your door panel and the floor. Adjust if desired or necessary. Track height can be adjusted after installation as outlined in succeeding steps.

- ❗ Add 3/4" to this dimension if you are using the optional floor guide channel without door recess.
- ② Mark the track centerline on your wall.
- ③ On the wall, mark the centerline of the door opening. This mark also locates the middle of the track (or track run if multiple tracks are connected).
- ④ Translate hole pattern in the rear track base to the track centerline line.
- ❗ Ensure that the determined lateral track wall position is considered.

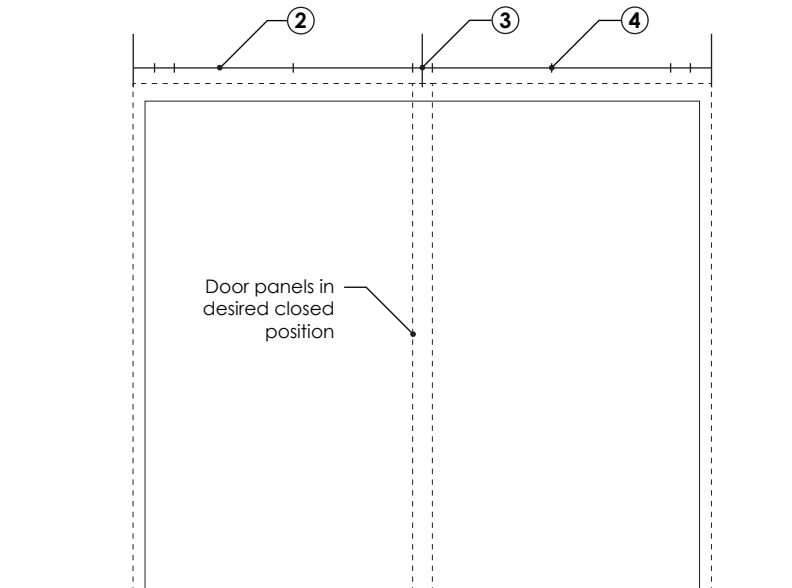

5. CONNECT TRACK BASES

Installations with multiple adjoining tracks are required to be interlocked in order to provide a continuous weight bearing surface. Reference track mounting point hole spacing in table below. Skip to the next step for single-track installations.

- ① Butt track bases end-to-end ensuring that the colored sticker dot indicators are matching and face track connection point(s) as shown.
- ② Using the track connector washer plate centered over the seam as a template, mark track bases for drilling.
- ③ Drill 13/64" holes in each track base.
- ④ Connect track bases by installing the track connector as shown. Ensure that washer plate teeth align with teeth in the track base before tightening.
- ⑤ Using a torque wrench, tighten fasteners to 48 inch-lbs (4 ft-lbs).

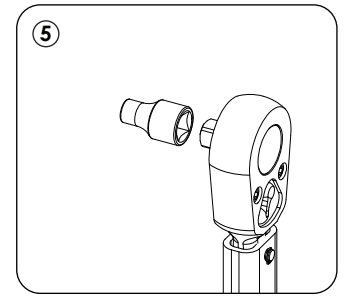

Panel weight	X Minimum	X Maximum
All	1-1/2"	3"

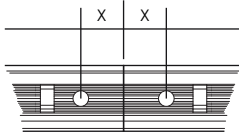

Track connectors are mandatory for all adjoined tracks in order to provide a continuous weight bearing surface.

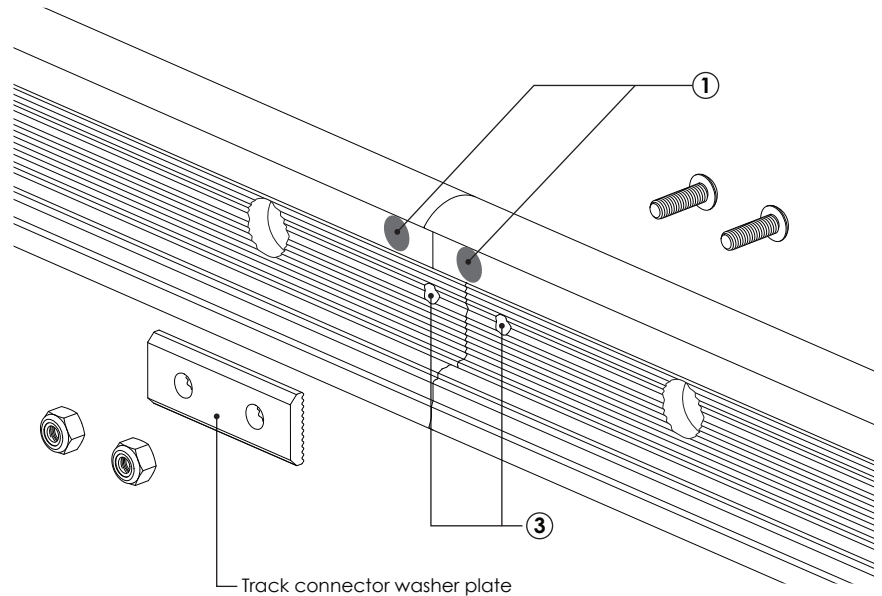

6. INSTALL DRYWALL INSERTS

This step is for walls with a non-structural surface only. I.e., drywall, pin-up board or other materials that are structurally weaker than the substrate. Skip to the next step if your finished wall surface is structural.

- ① Use a 1-3/4" Forstner bit or similar to remove the drywall at each mounting point.
- ② Place a drywall insert into each cavity.
- ⓘ To perform their function, drywall inserts must be up against the structural material of your wall and flush with the finished surface. If needed, use the included steel shims as shown.

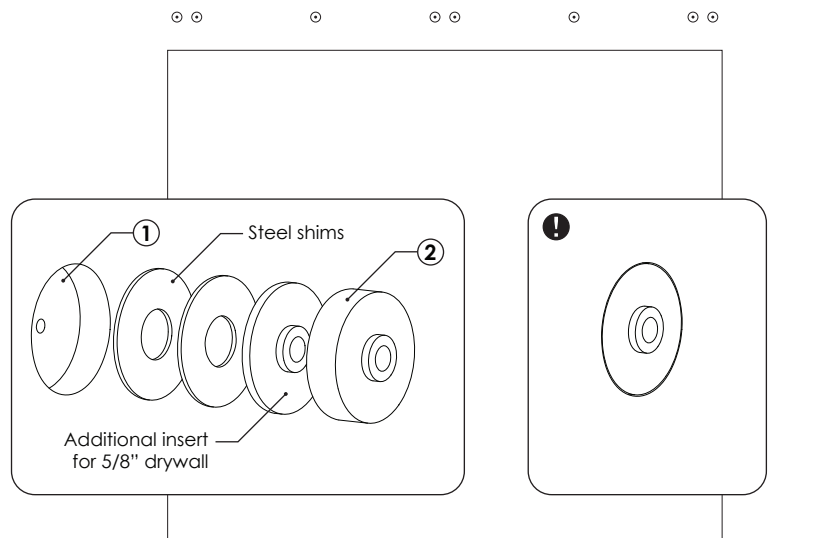

7. PILOT DRILL STRUCTURAL WALL

- ① Drill a pilot hole at each mounting point.
- ❗ Ensure that each mounting point engages an appropriate amount of structural material.
- ❗ Metal-studded framed walls must have 3" of solid blocking secured to studs or other framing members at each mounting point.
- ❗ Wood framed walls must have 3" of solid wood blocking secured to studs or other framing members. Mounting points can alternatively be secured to stud centers.



Structural requirements and suitability of other wall conditions to be determined by contractor or other qualified professional.



8. DETERMINE WALL CLEARANCE

- ① Taking any protruding wall element into consideration, determine the desired door panel to wall surface clearance. Examples include: baseboard, door trim, electrical outlets and wall switches.
- ② Identify the most appropriate track stand-off configuration referencing drawings below.
- ❗ 3/8" minimum recommended door panel to wall surface clearance.
- ③ Wall clearance can be further adjusted based on trolley location on top of door panel. Reference step 16.

*Minimum achievable system wall clearance is dependant upon door panel thickness.

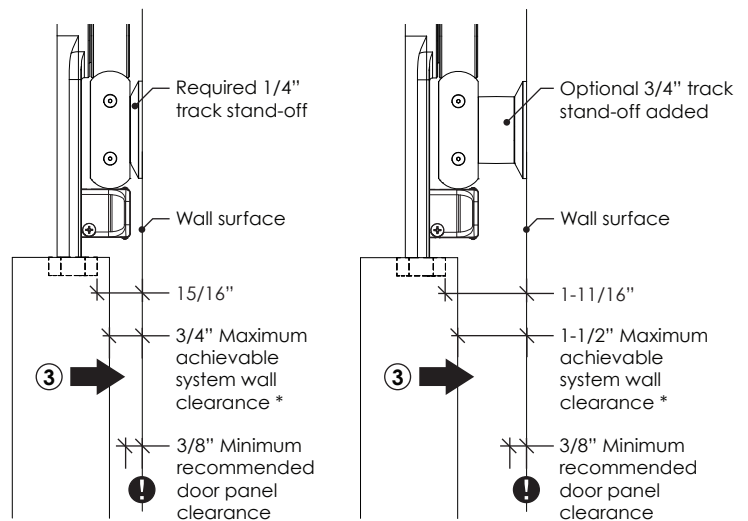

9. INSTALL DOOR STOPS

- ① Slide one door stop into each end of both track bases. Do not yet tighten fasteners.
- ⚠ If installing Premium Door Stops, reference applicable installation instructions in parallel.

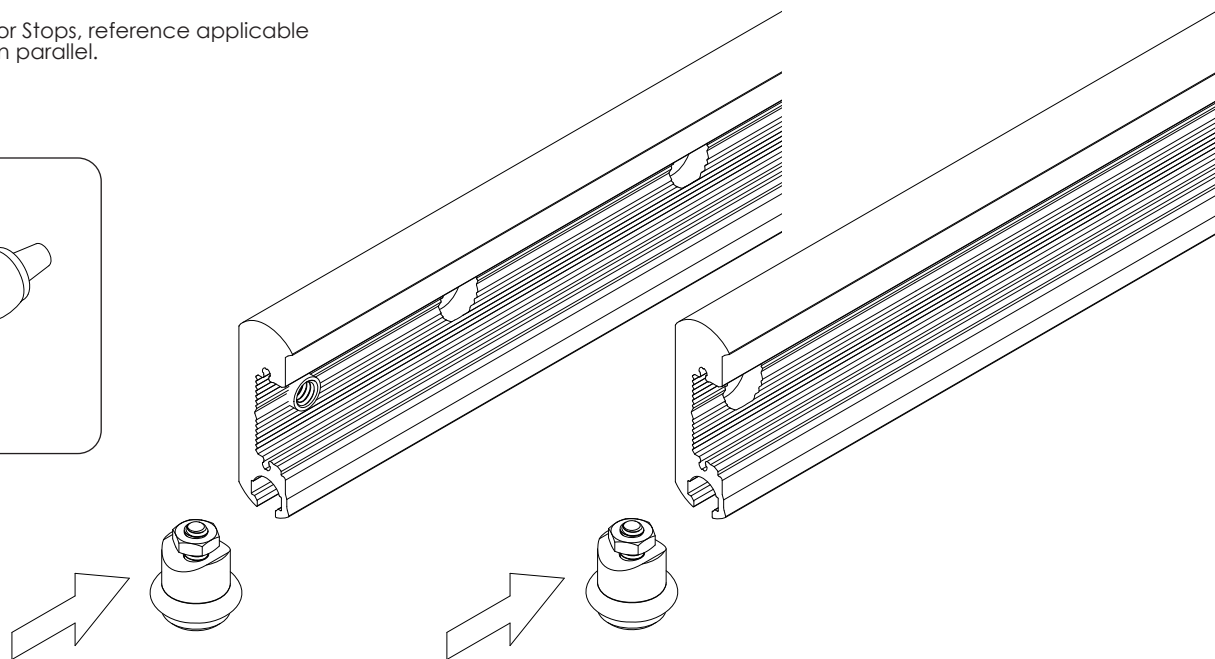
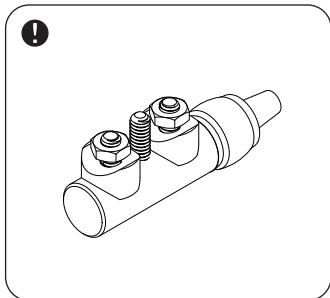

10. INSTALL END CAPS

- ① Gently secure end caps to each end of both track bases.
- ⚠ Do not over-tighten!

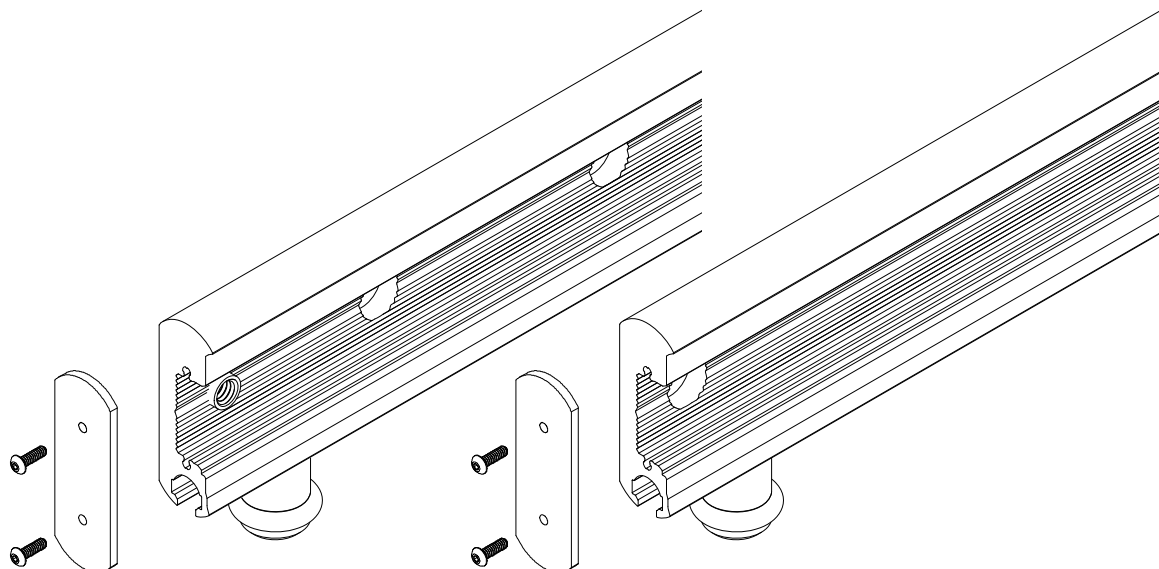

11. MOUNT REAR TRACK BASE TO WALL

- ① If needed, gently press to slide track springs to be 1" away from holes to prevent clamping a spring under track washer plate. Evenly space springs along the length of track to ensure track cover is well-retained.
- ② With the track base slot facing down, loosely install one end of your track with the selected stack-up of track stand-offs and corresponding mounting fastener.
- ③ Repeat with the opposite end of the track.
- ⚠ Support the track assembly along its length if multiple tracks are connected.
- ④ Loosely install the remaining mounting points.

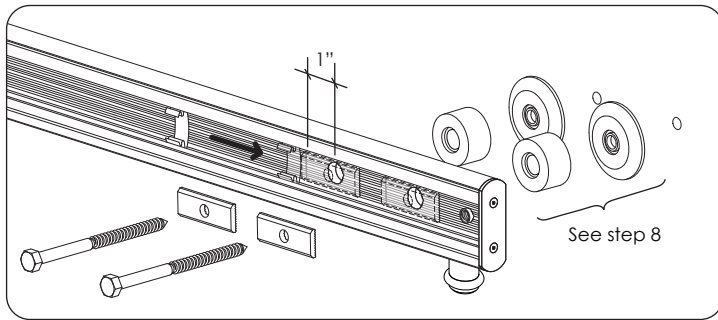

⚠ Krownlab offers a range of mounting point fasteners for different wall conditions. Lag screws for walls with wood blocking are illustrated here. Contractor or other qualified professional to ensure suitability of provided fasteners for site-specific wall conditions.

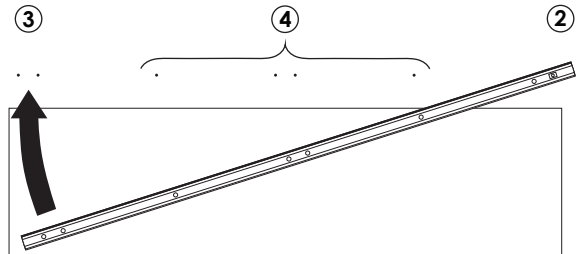

⚠ Krownlab's products are to be secured to structural elements able to support the weight of the door panel(s) and the dynamic forces of a sliding door system as determined by a qualified professional.

12. LEVEL AND ADJUST REAR TRACK HEIGHT

- ① Snug, but don't yet tighten each track fastener starting at the center and moving toward the ends. For maximum adjustment, start by positioning the washer plate in the center (neutral) position.
- ⚠ Be sure to account for sloped or uneven floor when determining final desired track height.
- ② Using a level, adjust the position of the washer plate at each mounting point until track is level. If desired, adjust overall track height.
- ⚠ Ensure that washer teeth align with teeth in the track base before tightening fasteners.
- ③ Tighten all mounting points, doing final tightening by hand.
- ⚠ Do not over-tighten to deform track washer plates.

⚠ Installation on a vertical surface is required in order to ensure track base is installed plumb.

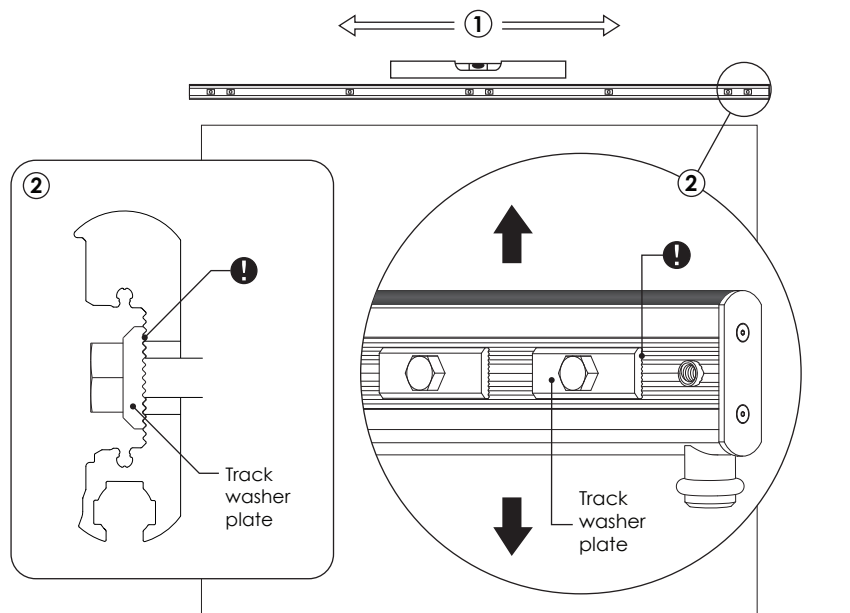
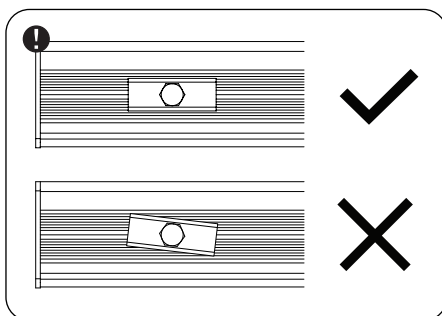

13. SYSTEM OPTION - INSTALL TRACK SHIMS

- ① Sight down the length of your track to determine if unevenness in the wall surface is causing your track to bow. Skip to the next step if track base is straight.
 - ② If out of true, loosen select track attachment points as needed and insert shims from below as shown. Ensure that the opening of the shim faces up. Start with one of the thinner shims, adding and swapping shims as needed until the track is straight along entire length to within the thickness of one shim.
- ⚠ Never use more than one shim kit at any mounting point. Track shims may only be used at mounting points that pull the track out of true.
 - ⚠ NOTE: Bowing in the track will negatively affect the system performance, causing increased friction and excessive wear. Krownlab's warranty does not cover wear caused by improper installation.
- ③ Retighten track fasteners to provided specifications.

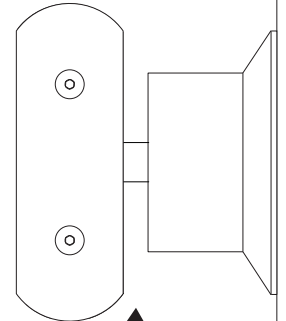
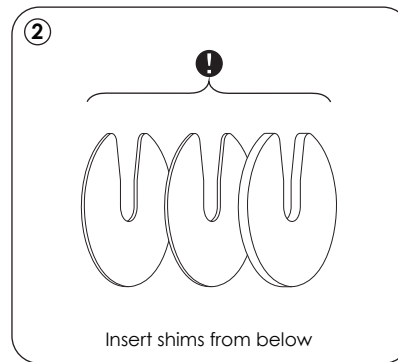

Do not use shims for the purpose to extend the track standoff distance.

14. SECURE REAR TRACK COVER

- ① Confirm that track base is level, straight, and that all mounting points have been securely fastened.
 - ② Inspect each track spring to ensure no interference with the mounting hardware and that they are evenly spaced along the length of the track base.
- ⚠ For installations with multiple connected tracks, ensure that the colored sticker dot indicators on inside of track cover are matching track base color and face track connection point(s).
 - ⚠ Ensure that the arrow on the inside of the track cover is facing up.
- ③ Carefully reattach track cover(s) to track base confirming fully seated and securely attached along the entire length. Adjust track spring locations if needed.

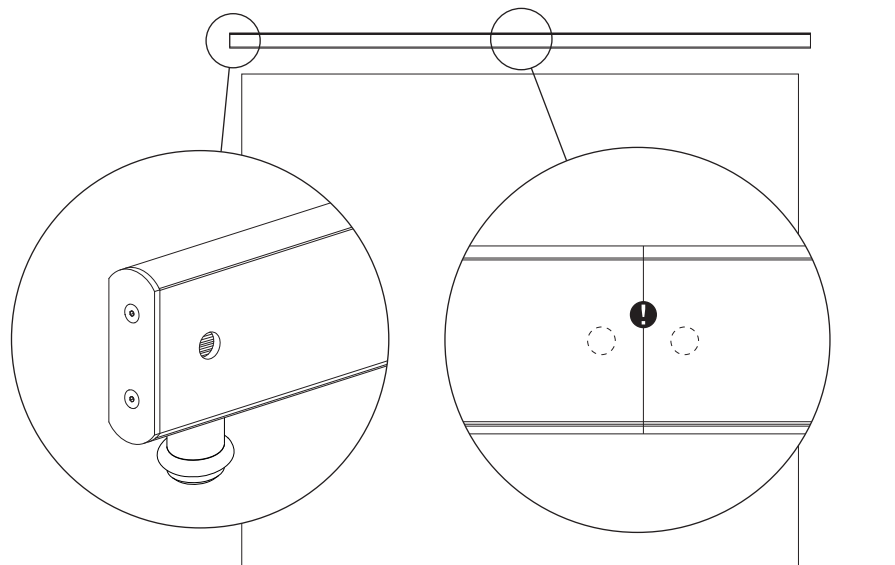
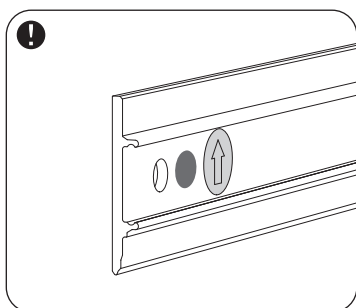
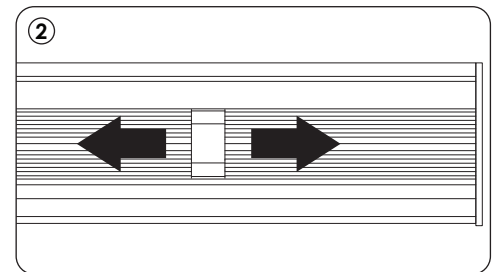

15. PREPARE FRONT AND REAR DOOR PANELS FOR

Refer to the separate installation instructions for the floor guide that is included with your order*. Once door is appropriately prepared, return to this document for next steps.

*Included floor guide may vary from examples shown below.

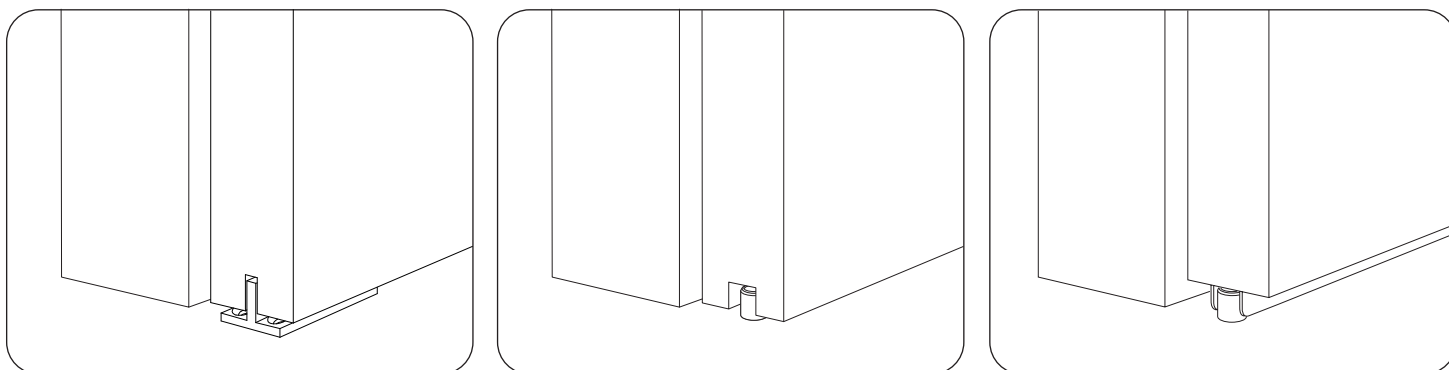

Installation of a floor guide is required and must for safety be engaged along the full length of door travel.

16. PREPARE FRONT AND REAR DOOR PANELS FOR TROLLEYS

- 1 Route the top of the door panels to accept the trolleys as shown.
- 2 Also prepare doors for - but do not yet install - door pulls and other door hardware part of the installation.
- 3 Adjust location of recesses to achieve the right door panel clearance from wall and door trim. Minimum dimension is driven by door panel material.



Fasteners are to be secured to the door panel top rail header and are to engage the horizontal grain, not the end-grain of the vertical stile.

Trolleys are to be secured to structural material able to support the weight of the door panel and the dynamic forces of a sliding door system.

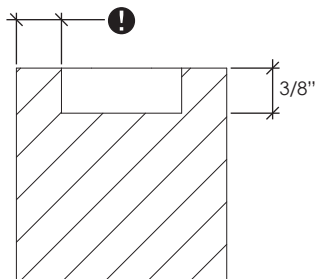
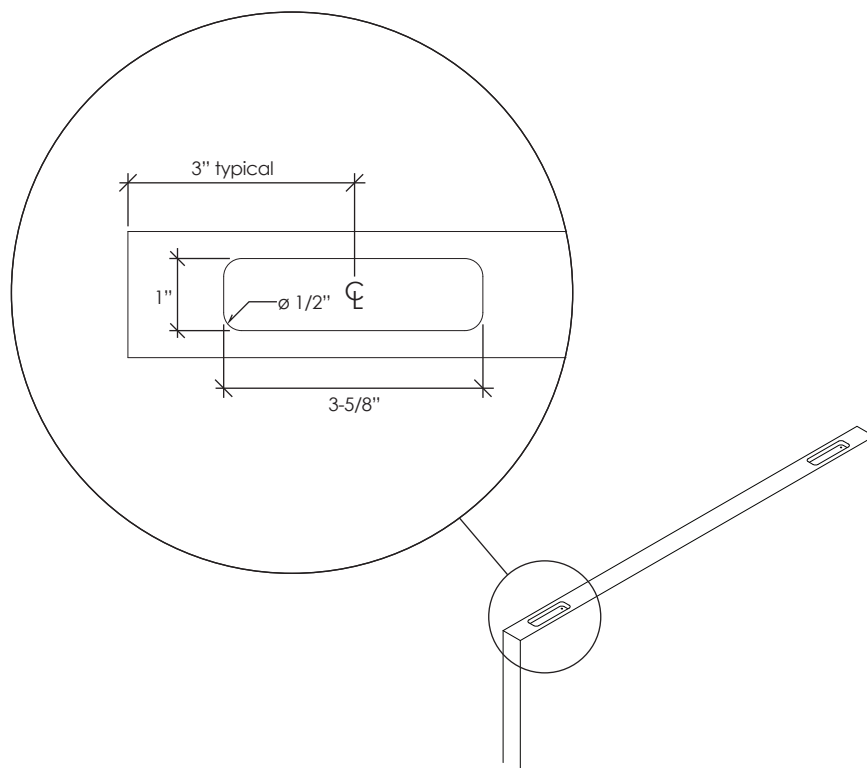

17. ATTACH TROLLEYS TO REAR DOOR PANEL

- ① Drill pilot holes and securely attach the trolleys with the fasteners provided using a torque wrench. Tighten fasteners to between 36 and 108 inch-lbs (3-9 ft-lbs), depending on door materials.
- ⚠ Ensure that the routed door panel recesses are flat, and that trolleys are installed parallel to the face of the door panel.
- ② Carefully hang rear door panel.
- ⚠ Do not yet install your door pulls or other door hardware.

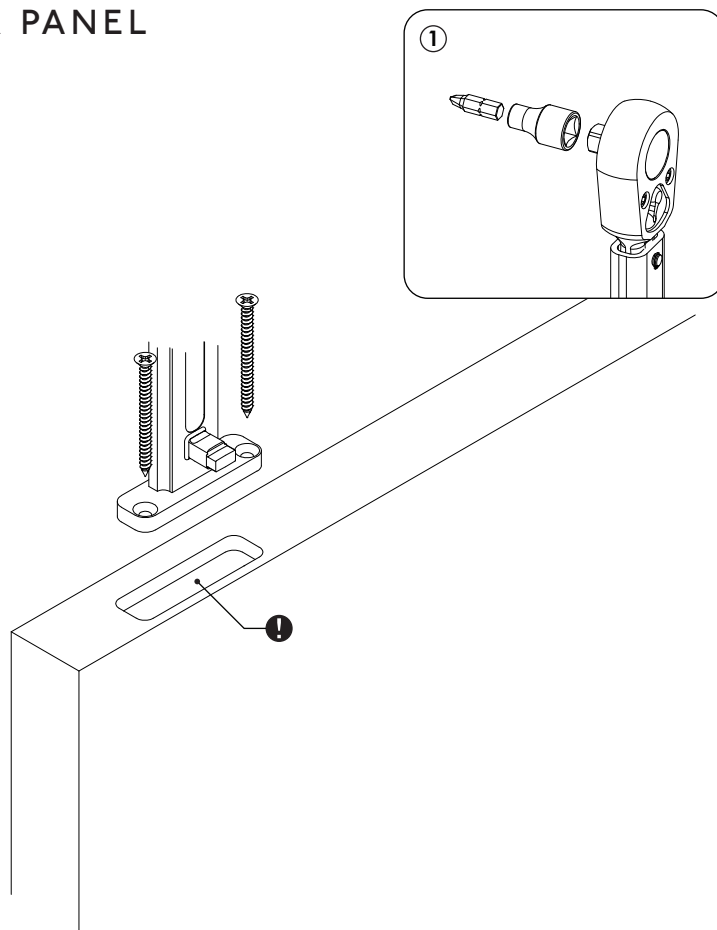
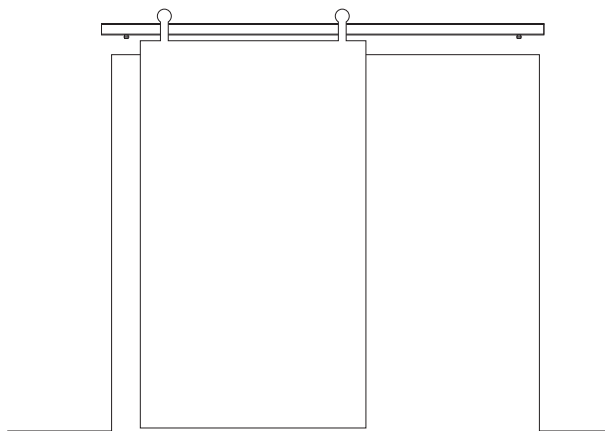

18. ADJUST REAR DOOR PANEL HEIGHT

- ① If desired, door panel height can be adjusted up or down by raising or lowering the track base as outlined in step 12.

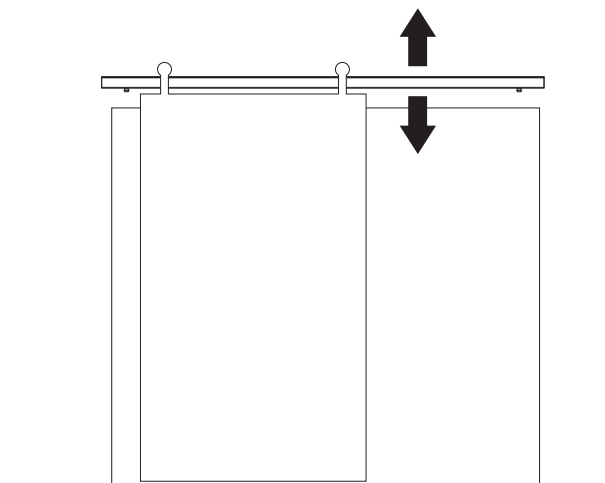

19. INSTALL REAR DOOR PANEL SAFETY STOPS

If installing Premium Door Stops, reference those installation instructions in parallel.

- 1 Remove protective cap from trolley post.
- 2 For **Standard Door Stop** installation, place curved safety stops towards door stops, and flat safety stops away from door stops as shown. For **Premium Door Stop** installation, reference separately provided installation instructions.
- 3 Ensure the first safety stop is fully seated and properly aligned so that half of the trolley post is completely covered by the safety stop.
- 3 Slide the second safety stop over the other side of the post.
- 4 Ensure that both safety stops are aligned and fully seated.
- 4 Thread provided screws into both sides of the safety stops using a #2 Phillips Screw Driver and lightly tighten.
- 5 Repeat above steps for second trolley with reverse safety stop positions.

NOTE: Keep the protective caps and reuse when removing and rehangng door panel to prevent damage to the track.



Not correctly installing safety stops can result in the door panel derailing during normal use which can cause damage and a safety hazard.

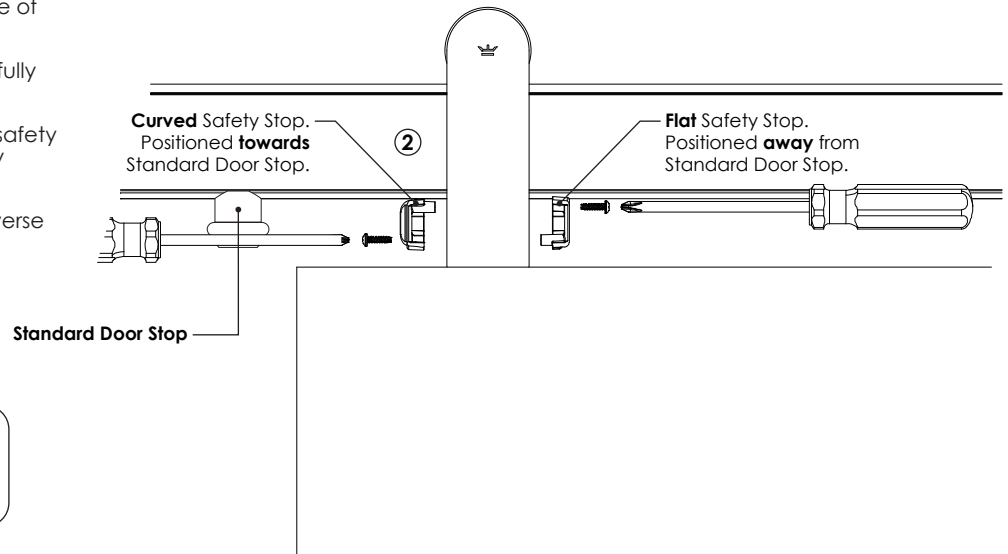
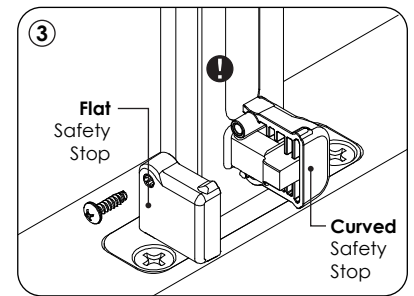

20. INSTALL REAR FLOOR GUIDE

Refer to the separate installation instructions for the floor guide that is included with your order*. Once installed, continue to next step.

*Included floor guide may vary from example(s) shown below.

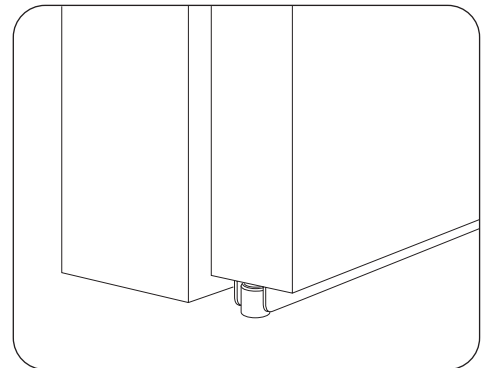
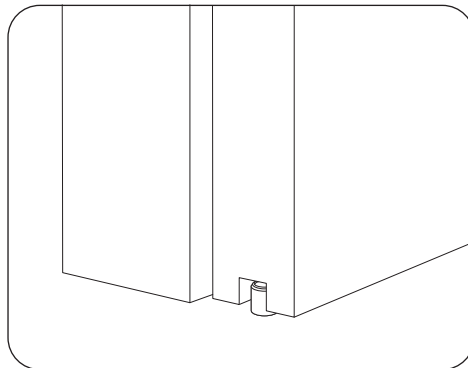
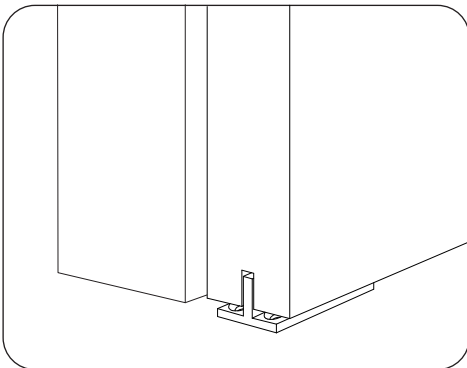

Installation of a floor guide is required and must for safety be engaged along the full length of door travel.

21. MOUNT FRONT TRACK BASE TO REAR TRACK

- ① If needed, gently press to slide track springs to be 1" away from holes to prevent clamping a spring under track washer plate. Evenly space springs along the length of track to ensure track cover is well-retained.
- ② With the track base slot facing down, loosely install one end of your track with the provided stack-up of track stand-offs and mounting fasteners.
- ③ Repeat with the opposite end of the track.
- ⚠ Support the track assembly along its length if multiple tracks are connected.
- ④ Loosely install the remaining mounting points.

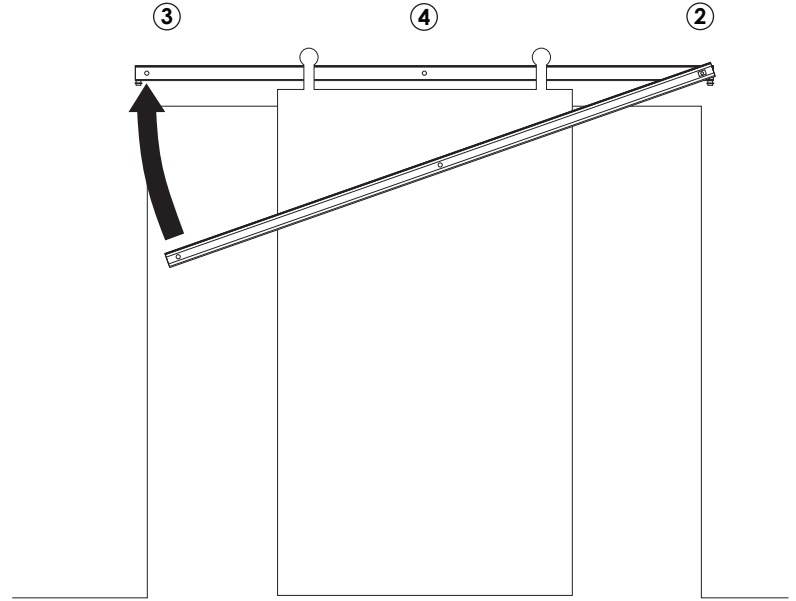
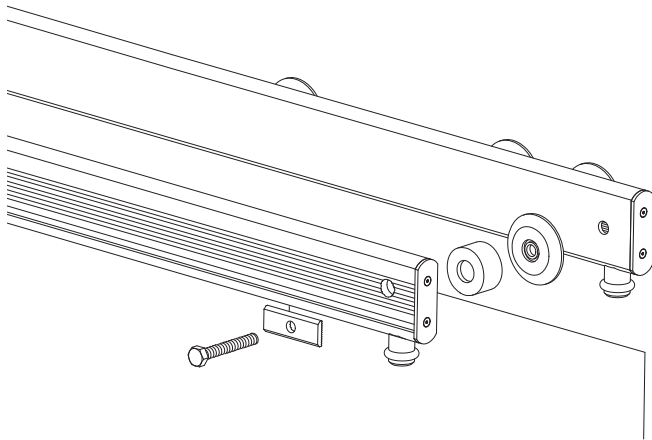

22. LEVEL AND ADJUST FRONT TRACK HEIGHT

- ① Snug, but don't yet tighten each track fastener starting at the center and moving toward the ends. For maximum adjustment, start by positioning the washer plate in the center (neutral) position.
- ② Using a level, adjust the position of the track washer plate at each mounting point until track is level, and level with rear track. If desired, adjust overall track height.
- ⚠ Ensure that washer teeth align with teeth in the track base before tightening fasteners.
- ③ Using a torque wrench, tighten fasteners to 120 inch-lbs (10 ft-lbs).
- ⚠ Do not over-tighten to deform track washer plates.

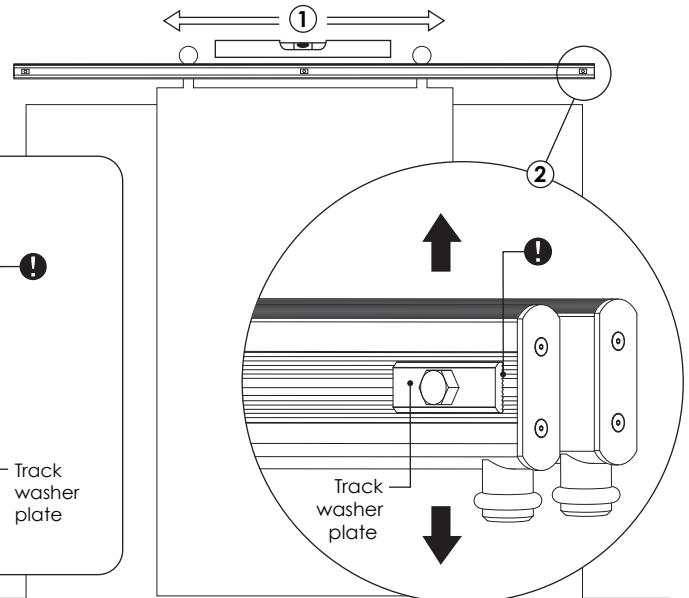
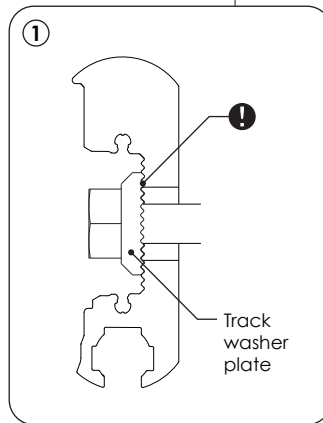
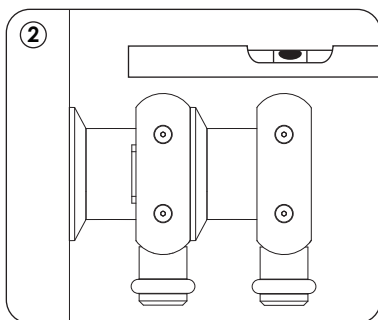
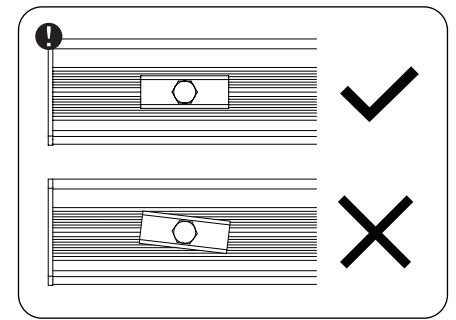
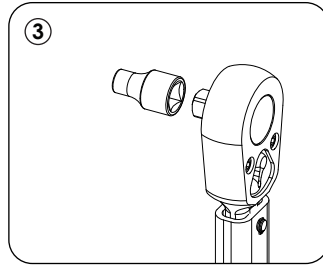

23. SECURE FRONT TRACK COVER

- 1 Confirm that track base is level, straight, and that all mounting points have been securely fastened.
- 2 Inspect each track spring to ensure no interference with the mounting hardware and that they are evenly spaced along the length of the track base.
- ⚠ For installations with multiple connected tracks, ensure that the colored sticker dot indicators on inside of track cover are matching track base color and face track connection point(s).
- ⚠ Ensure that the arrow on the inside of the track cover is facing up.
- 3 Carefully reattach track cover(s) to track base confirming fully seated and securely attached along the entire length. Adjust track spring locations if needed.

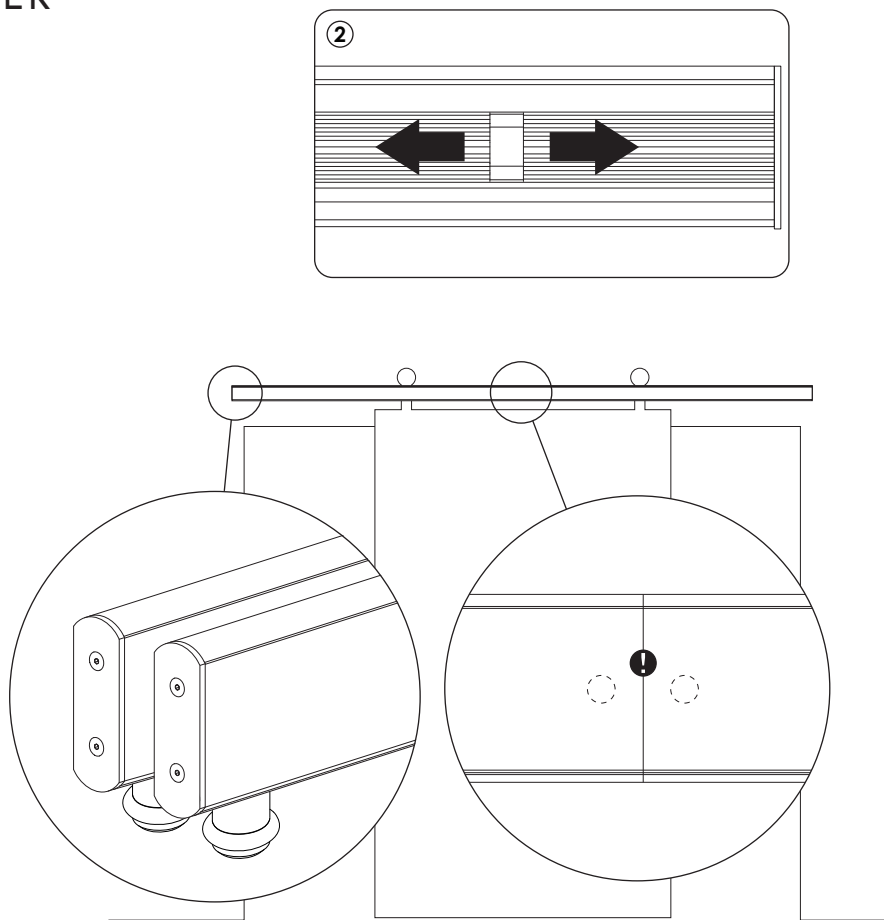
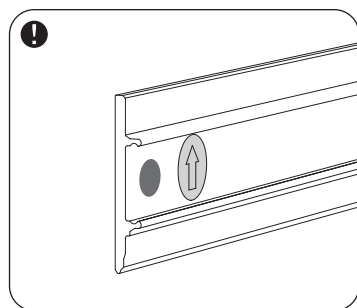

24. ATTACH TROLLEYS TO FRONT DOOR PANEL

- 1 Drill pilot holes and securely attach the trolleys with the fasteners provided using a torque wrench. Tighten fasteners to between 36 and 108 inch-lbs (3-9 ft-lbs), depending on door materials.
- ⚠ Ensure that the trolleys are installed parallel to the face of the door panel.
- 2 Carefully hang rear door panel.
- ⚠ Do not yet install your door pulls or other door hardware.

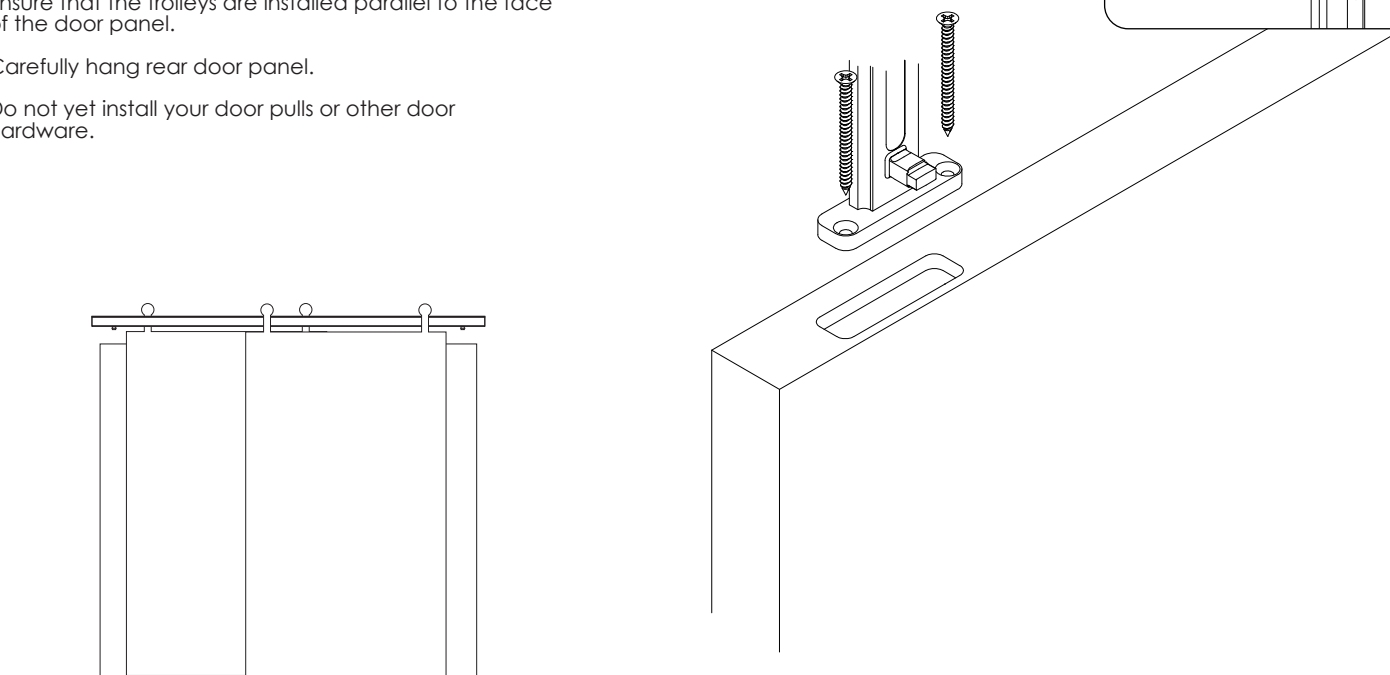
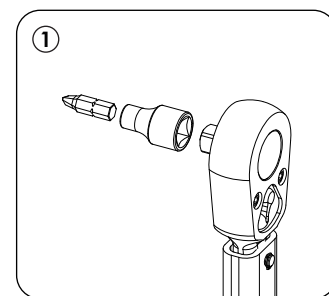

25. ADJUST FRONT DOOR PANEL HEIGHT

- ① If desired, door panel height can be adjusted up or down by raising or lowering the track base as outlined in step 22.

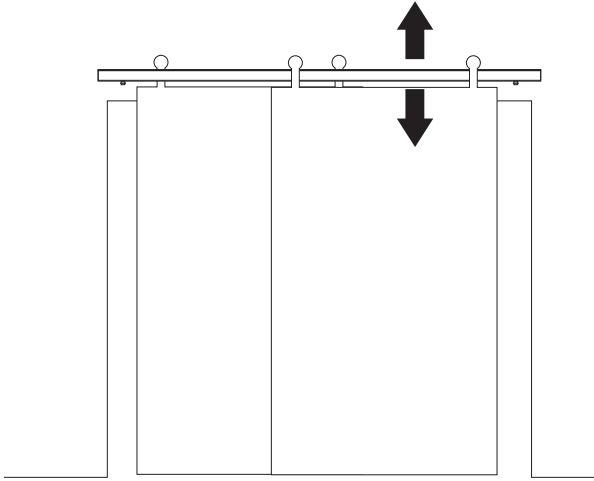

26. INSTALL FRONT DOOR PANEL SAFETY STOPS

If installing Premium Door Stops, reference those installation instructions in parallel.

- ① Remove protective cap from trolley post.
- ② For **Standard Door Stop** installation, place curved safety stops towards door stops, and flat safety stops away from door stops as shown. For **Premium Door Stop** installation, reference separately provided installation instructions.
- ⚠ Ensure the first safety stop is fully seated and properly aligned so that half of the trolley post is completely covered by the safety stop.
- ③ Slide the second safety stop over the other side of the post.
- ⚠ Ensure that both safety stops are aligned and fully seated.
- ④ Thread provided screws into both sides of the safety stops using a #2 Phillips Screw Driver and lightly tighten.
- ⑤ Repeat above steps for second trolley with reverse safety stop positions.

NOTE: Keep the protective caps and reuse when removing and rehang door panel to prevent damage to the track.

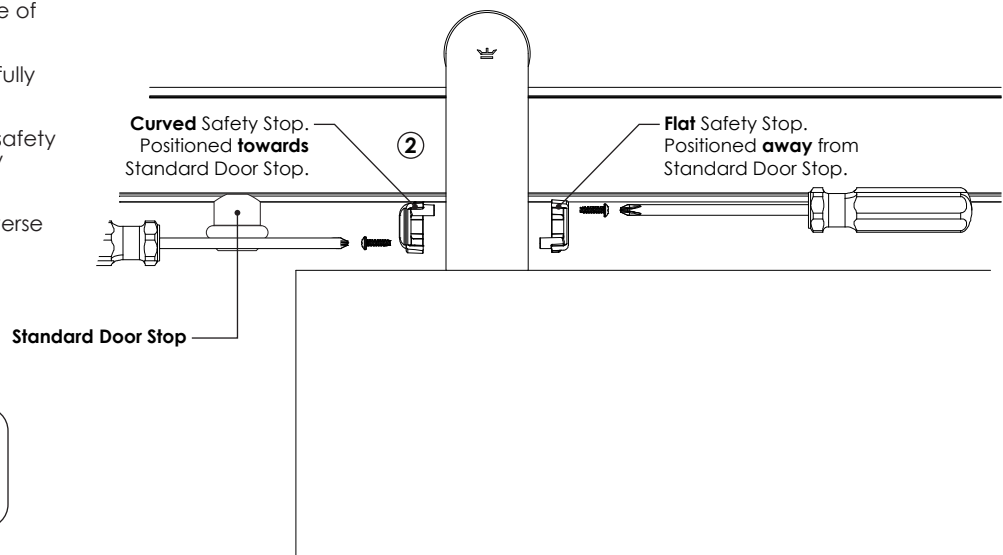
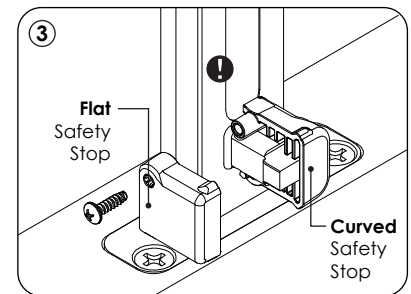

Not correctly installing safety stops can result in the door panel derailing during normal use which can cause damage and a safety hazard.

27. INSTALL FRONT FLOOR GUIDE

Refer to the separate installation instructions for the floor guide that is included with your order*. Once installed, continue to next step.

*Included floor guide may vary from examples shown below.

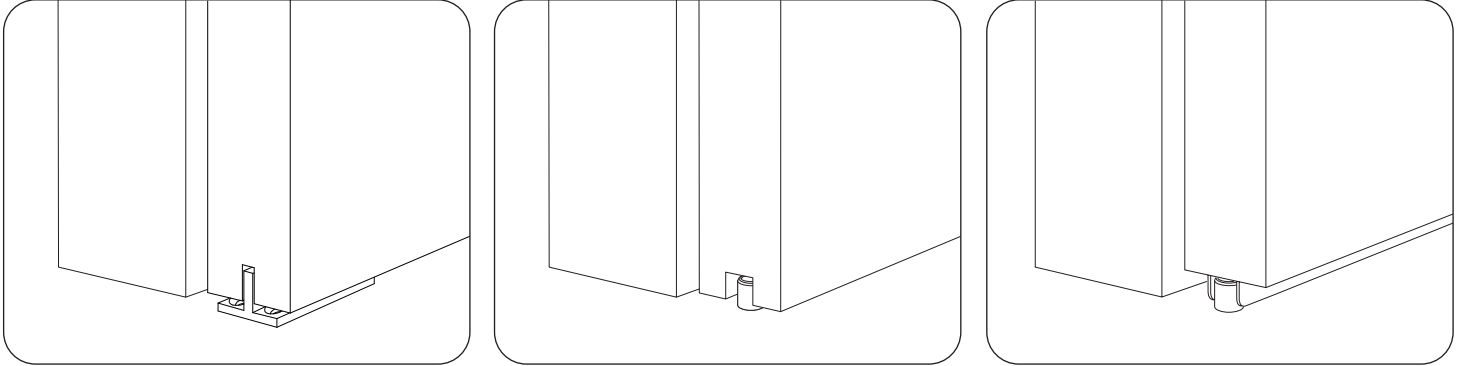

Installation of a floor guide is required and must for safety be engaged along the full length of door travel.

28. INSTALL DOOR PULLS

- ① If applicable, install door pulls following applicable installation instructions.

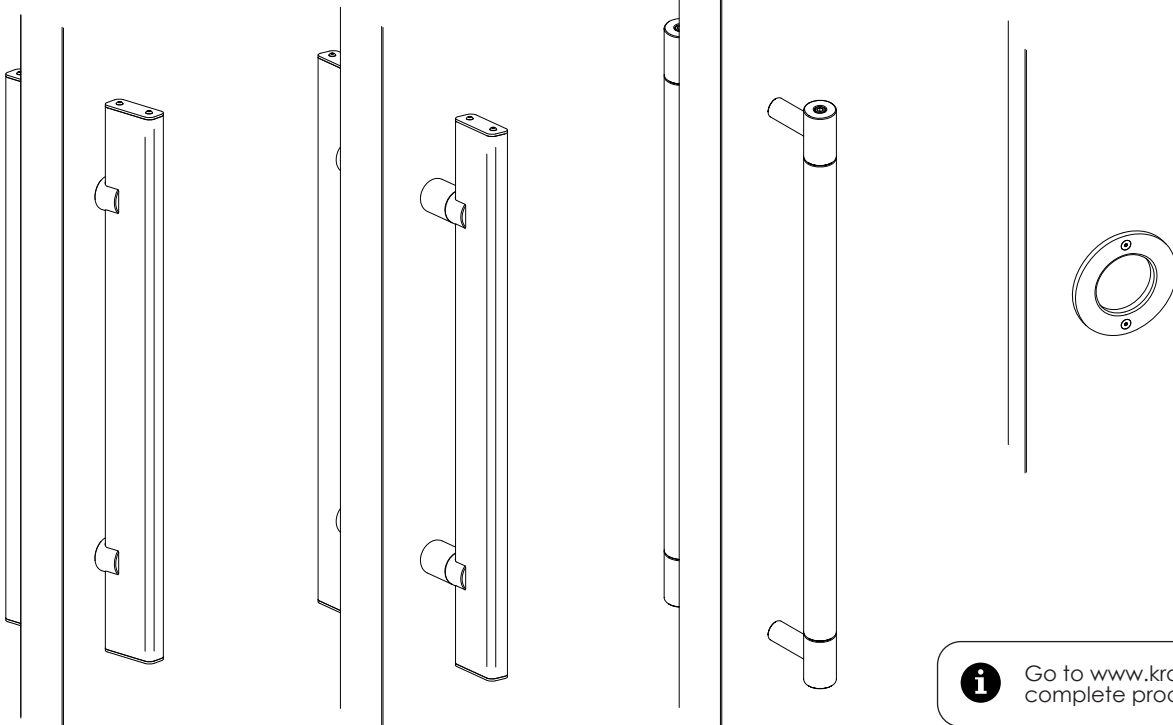

Go to www.krownlab.com for our complete product range.

29. SET DOOR TRAVEL

If installing Premium Door Stops, reference those installation instructions in parallel.

- 1 With the doors in their desired open positions, slide the door stops until they touch the safety stop of the nearby trolley.
- 2 Repeat with the doors in their desired closed position.
- 3 Tighten all door stop fasteners in place by hand.
- 4 Note minimum distance from track end.
- 5 Using a torque wrench, tighten fasteners to 110 inch-lbs (9.5 ft-lbs).

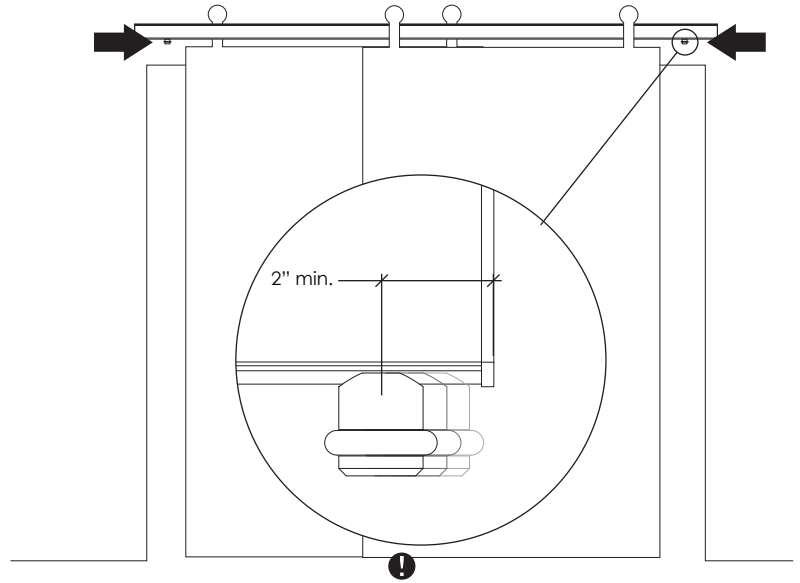
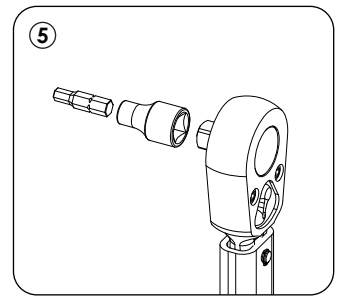

Not tightening door stops to provided specs can cause the door to slide off the end of the track and cause damage and a safety hazard.

30. CARE AND MAINTENANCE

- 1 Krownlab products require routine care and maintenance. Read and understand these requirements in our Product Care & Maintenance guide.
- 1 Thoroughly clean product and remove all debris and fingerprints immediately after installation as described in our Product Care & Maintenance guide.
- 2 Enjoy your new exceptional Krownlab Sliding Door System.



Not properly following Krownlab's Care & Maintenance guide can cause excessive wear and degrade product performance over time.