



PDX - ORE

AXEL

INSTALLATION INSTRUCTIONS

1 Locate all hardware components.

** Depends on track length*

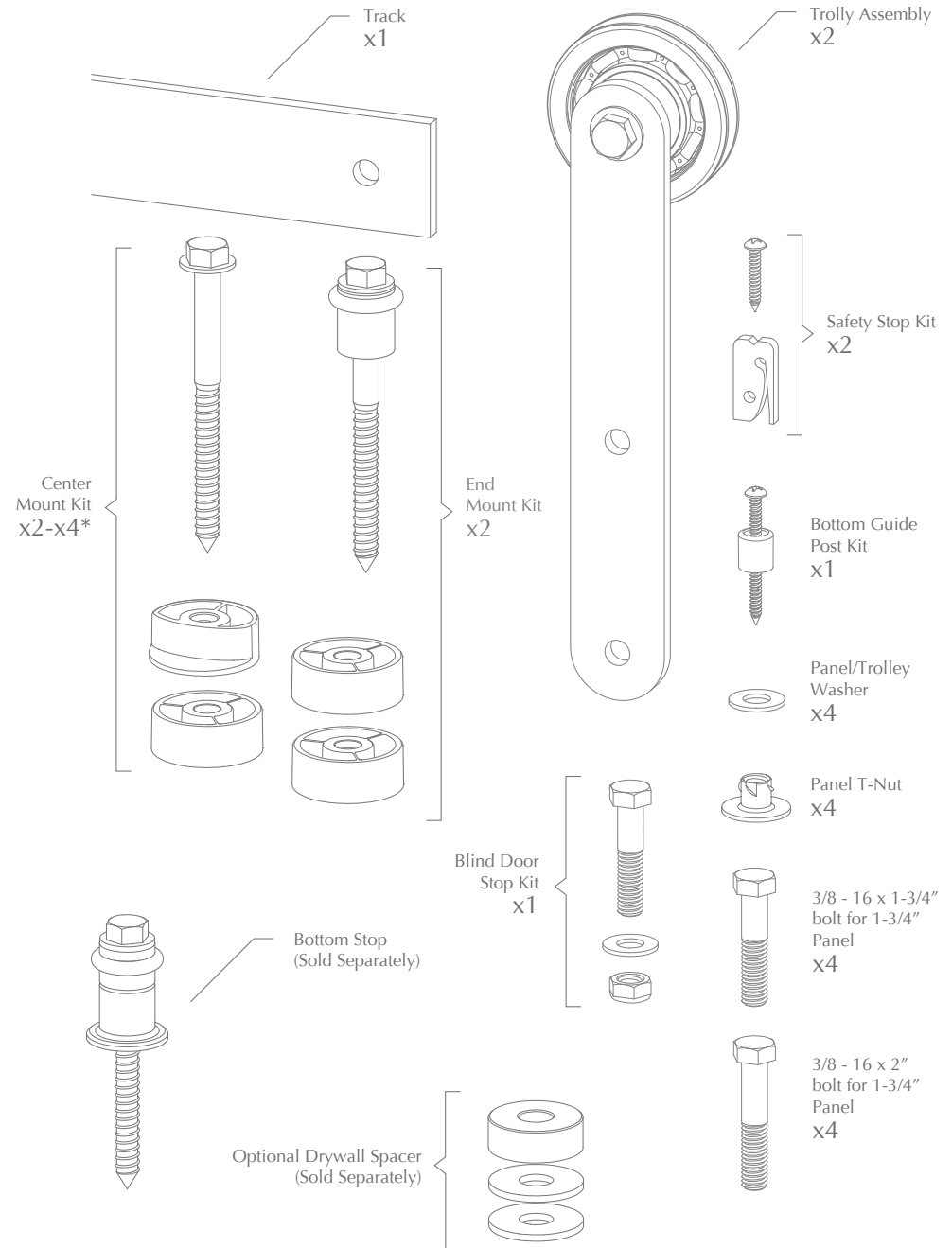

2 Determine if you need to modify your track.

AXEL comes in three sizes to suit most door openings:

- 70" track is designed for 32" opening + 36" door panel
- 94" track is designed for 44" opening + 48" door panel
- 116" track is designed for 55" opening + 59" door panel

If your door opening and panel match the dimensions listed above, Skip to step 4; otherwise, follow step 3.

For bi-parting installations with 2 doors and one opening, see steps 2, 3 and 4, shown at the right.

3 Modify your door travel by either of the following two options.

Option 1

Follow the instructions found here:
www.krownlab.com/axel-modify

Option 2

- Calculate panel overlap "X":
 $X = \text{Panel overlap} = (\text{panel width} - \text{opening width})/2$
- Calculate hole location: Hole location = $(\text{panel width} * 2) - X - 1$
- [Optional] Cut track 1" beyond additional hole.

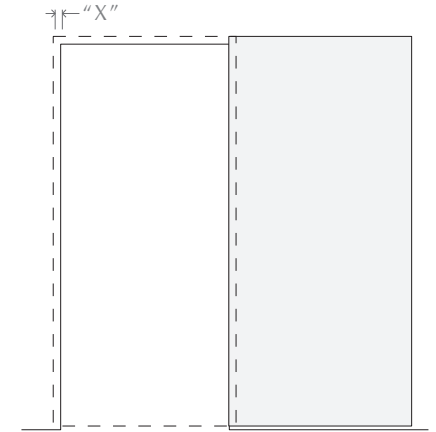

2 [For bi-parting installations only] Determine if you need to modify your track.

AXEL comes in three sizes to suit most door openings:

- 140" track is designed for 68" opening + two 36" door panels
- 188" track is designed for 92" opening + two 48" door panels
- 232" track is designed for 106" opening + two 59" door panels

Skip to step 4 if your door opening and panel match the dimensions listed above. Otherwise, follow step 3.

3 [For bi-parting installations only] Modify your door travel by either of the following two options.

Option 1

Follow the instructions found here:
www.krownlab.com/axel-modify

Option 2

- Calculate panel overlap "X":
 $X = \text{Panel overlap} = (\text{panel width} - \text{opening width})/2$
- Calculate hole location:
Hole location = $(\text{panel width} * 2) - X - 1$
- [Optional] Cut track 1" beyond additional hole.

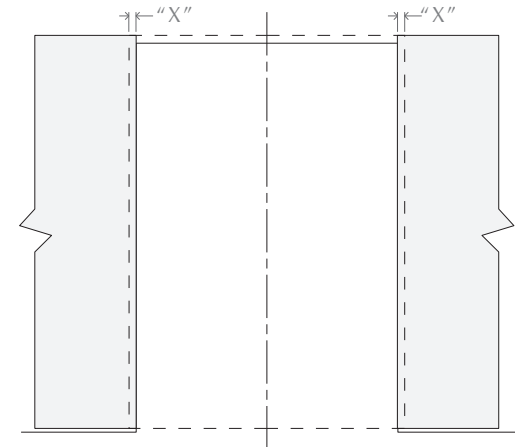

4 Determine track location.

- A. Centerline of track = $1\text{-}1/2'' + \text{door panel height}$
(if using optional bottom guide channel, add an additional $3/4''$).
- B. Install first trolley stop $1''$ to left or right of door opening.

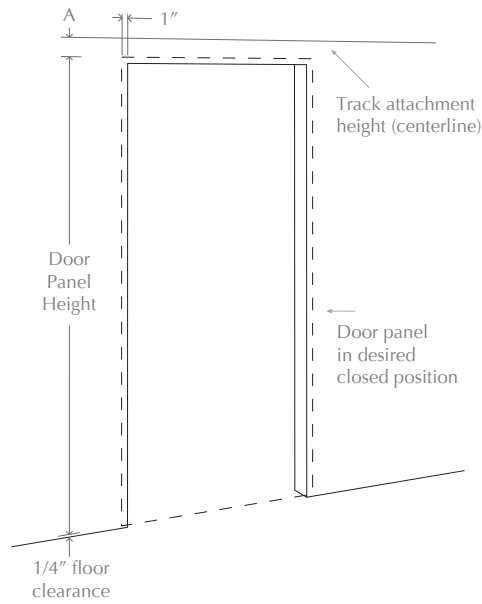

4 [For bi-parting installations only] Determine the track location.

- A. Centerline of track = $1\text{-}1/2'' + \text{door panel height}$
(if using optional bottom guide channel, add an additional $3/4''$).
 - B. Install trolley stops $1''$ off center of door opening.
- To finish your installation, follow steps 5 through 12.

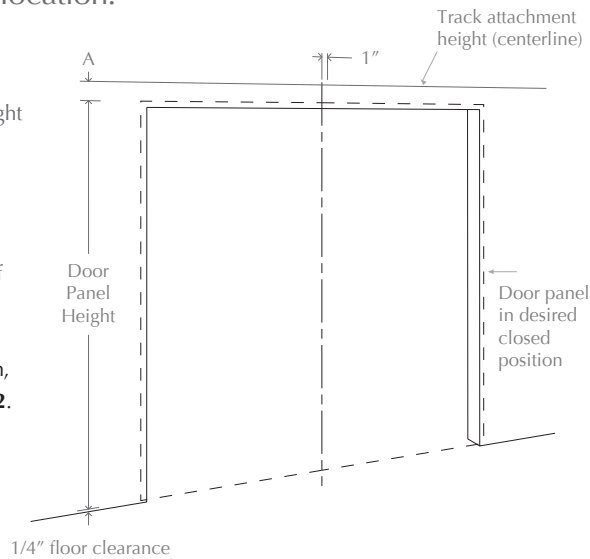

5 Install your track.

Use one spacer for $1\text{-}3/8''$ thick panels ($3/16''$ clearance behind panel).
Use both spacers for $1\text{-}3/4''$ panels ($7/16''$ clearance behind panel).

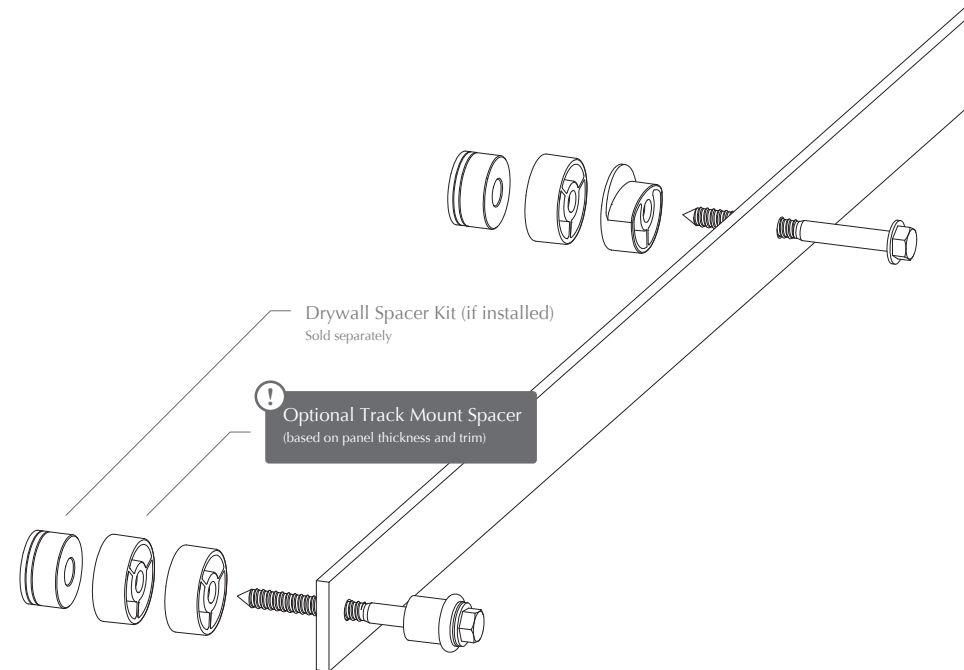

Black bumpers included in Trolley Stop Track Mount Kits are designed to stop the door panel. Position them at end of track, or where you want door panel to stop.

To ensure door panel stays in the fully open and closed positions, bias center holes slightly high.

6 Rout the bottom of door panel for bottom guide post.

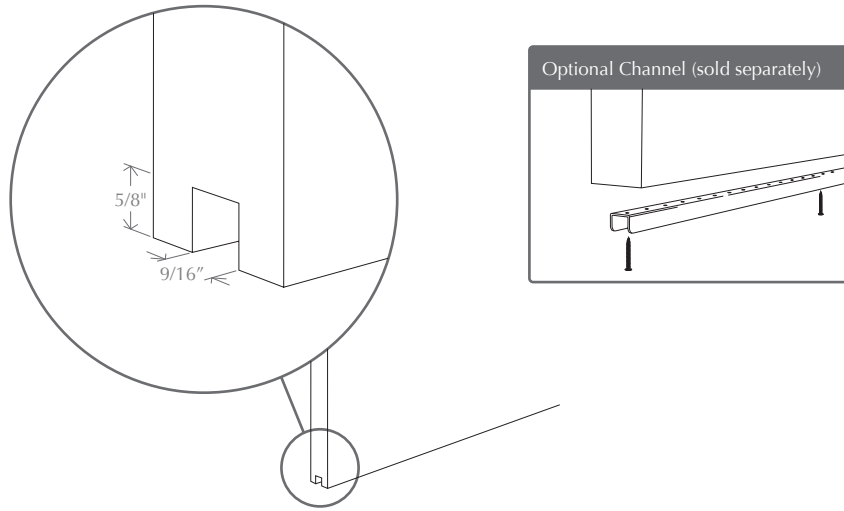

7 Drill holes in door panel for mounting trolleys.

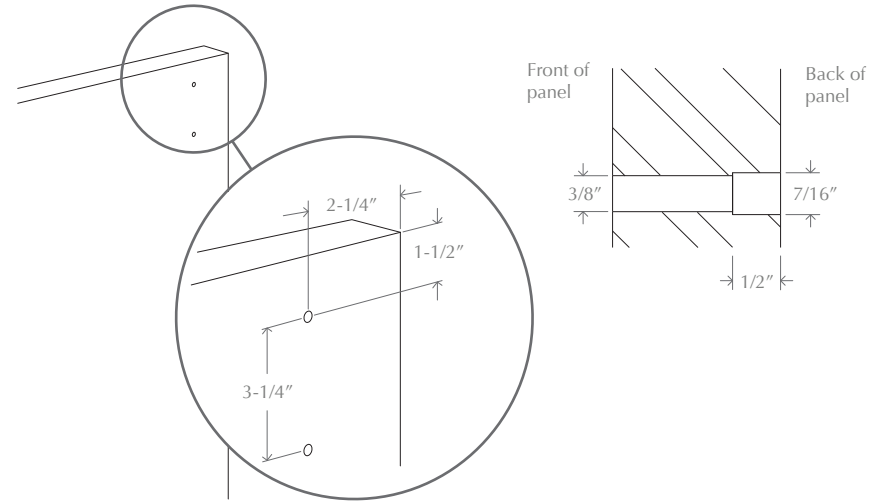

8 Install safety stop to top of door panel.
Do not over-tighten screw.

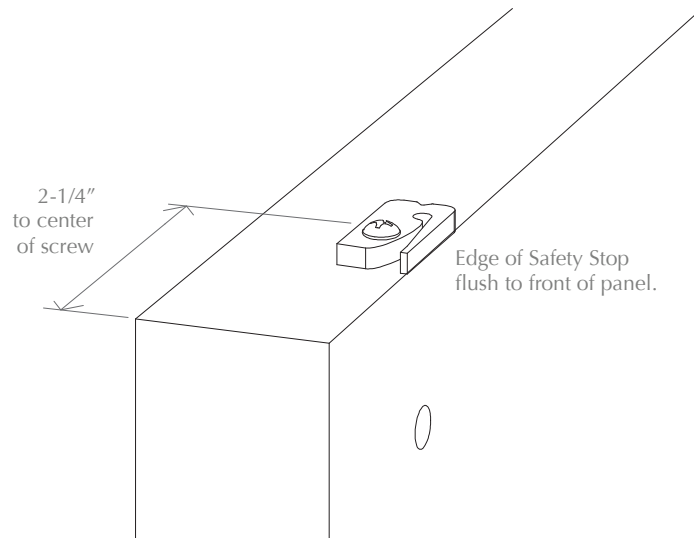

9 Mount trolleys to door panel.

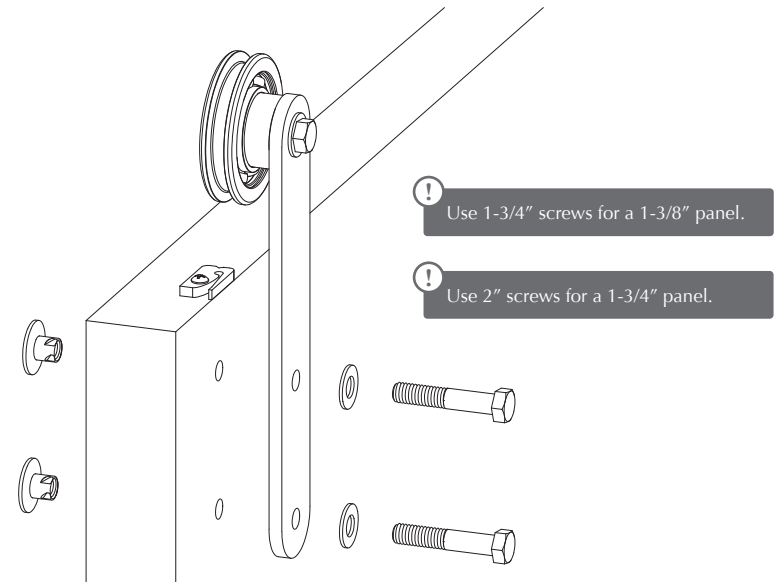

10 Determine bottom guide post location.

- A. Temporarily hang door panel, and guide door panel plumb if needed.
- B. Mark area on floor where door panel overlaps in open and closed position.
- C. Mark area on floor where centerline of bottom guide post falls.
- D. Remove door panel and install bottom guide post in panel overlap area marked in previous step, as shown below.

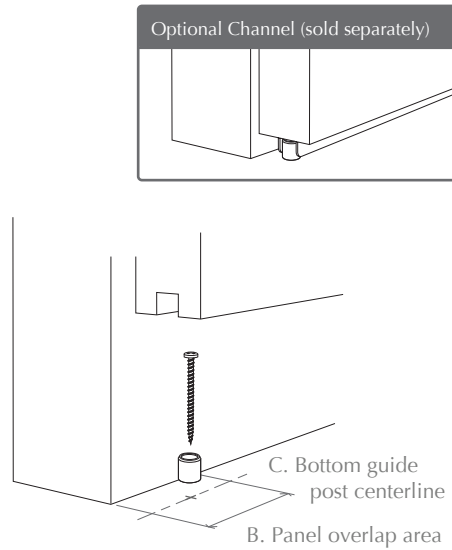

11 Re-hang door panel. Rotate safety-stop in place.

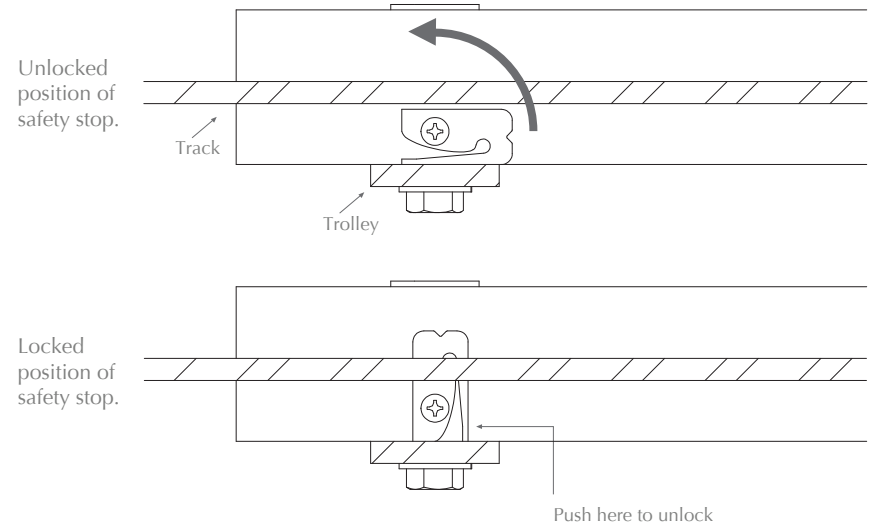

12 Product Care.

Common Parts:

Wheels (bearings) should occasionally be lubricated with bearing oil (e.g. SHC 630 Synthetic Gear and Bearing Oil by Exxon Mobil Corp: www.mobil.com).

Using a dry cloth, wipe bearing and wheel wearing surfaces and remove any build-up of dust or debris every few thousand cycles or every few months, whichever comes first.

Brushed Stainless:

To clean any time after installation, use a non-abrasive lint free cloth or sponge and household glass cleaner. (Remember to test an inconspicuous area prior to cleaning hardware.)

Do not use steel wool, or a Scotch Brite pad, as it can scratch the product.

Raw + Black Steel:

Maintain as much or as little as necessary for desired degree of patina. To prevent rusting, apply oil periodically.

13 Dispose of packing materials.

