

DOCUMENT:	PRODUCT SPECIFICATIONS - CONFIGURATIONS	DOOR APPLICATION:	ALCOVE, CORNER, BYPASSING	DRAWING SCALE:	3/4" = 1'-0" (1:16)	KROWNLAB 2351 NW York St. Portland, OR 97210 +1 503 292 6998 www.krownlab.com support@krownlab.com	
SYSTEM:	FREYA	PANEL THICKNESS:	5/16" TO 1/2"	UNITS:	INCHES		
MOUNTING STYLE:	GLASS	MAXIMUM WEIGHT:	TRACK CONFIGURATION DEPENDENT	DATE:	11/16/2023		

ALCOVE

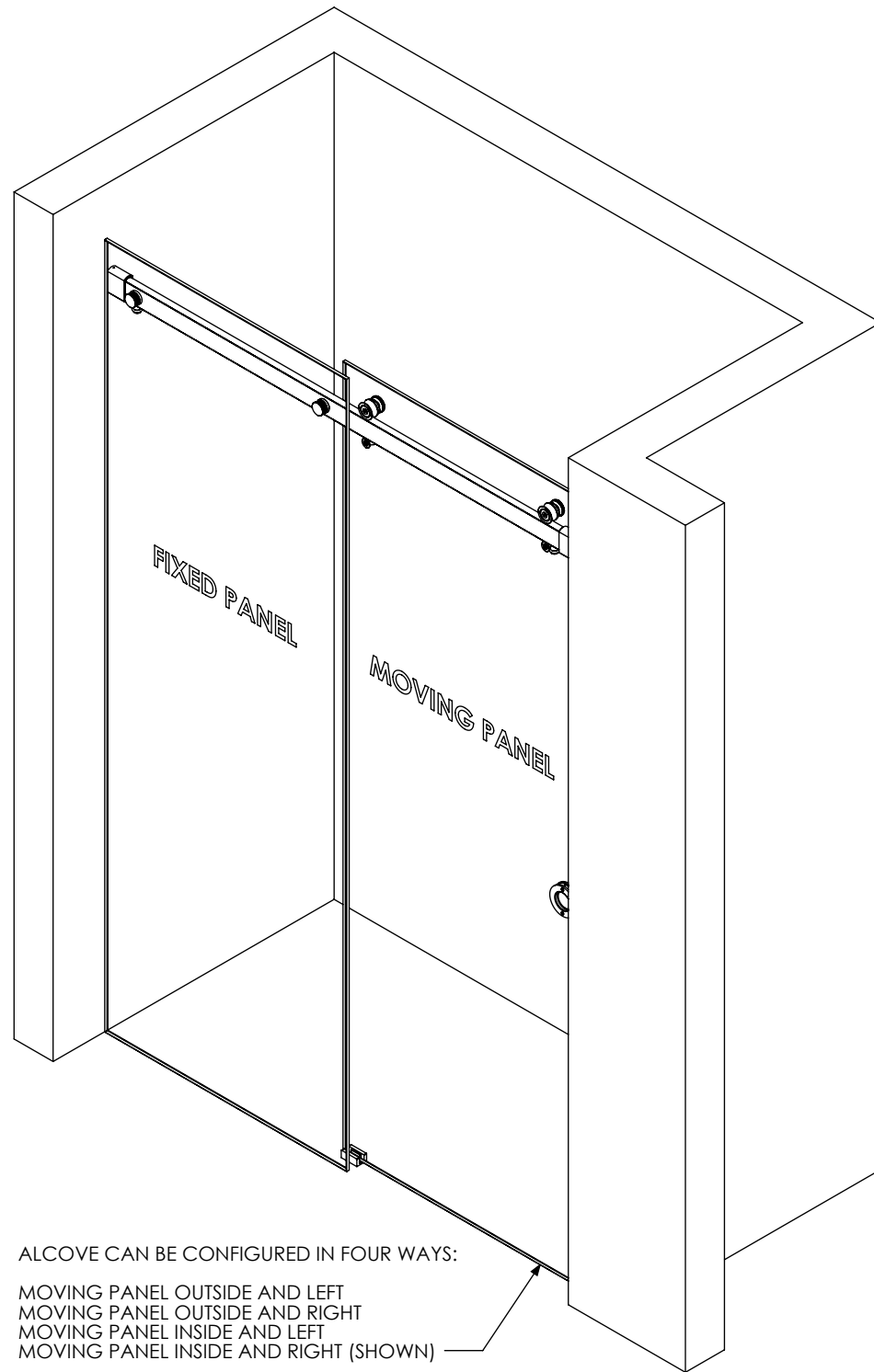

ALCOVE CAN BE CONFIGURED IN FOUR WAYS:
 MOVING PANEL OUTSIDE AND LEFT
 MOVING PANEL OUTSIDE AND RIGHT
 MOVING PANEL INSIDE AND LEFT
 MOVING PANEL INSIDE AND RIGHT (SHOWN)

ALCOVE GLASS THICKNESS RANGE: 3/8" To 1/2"

CORNER

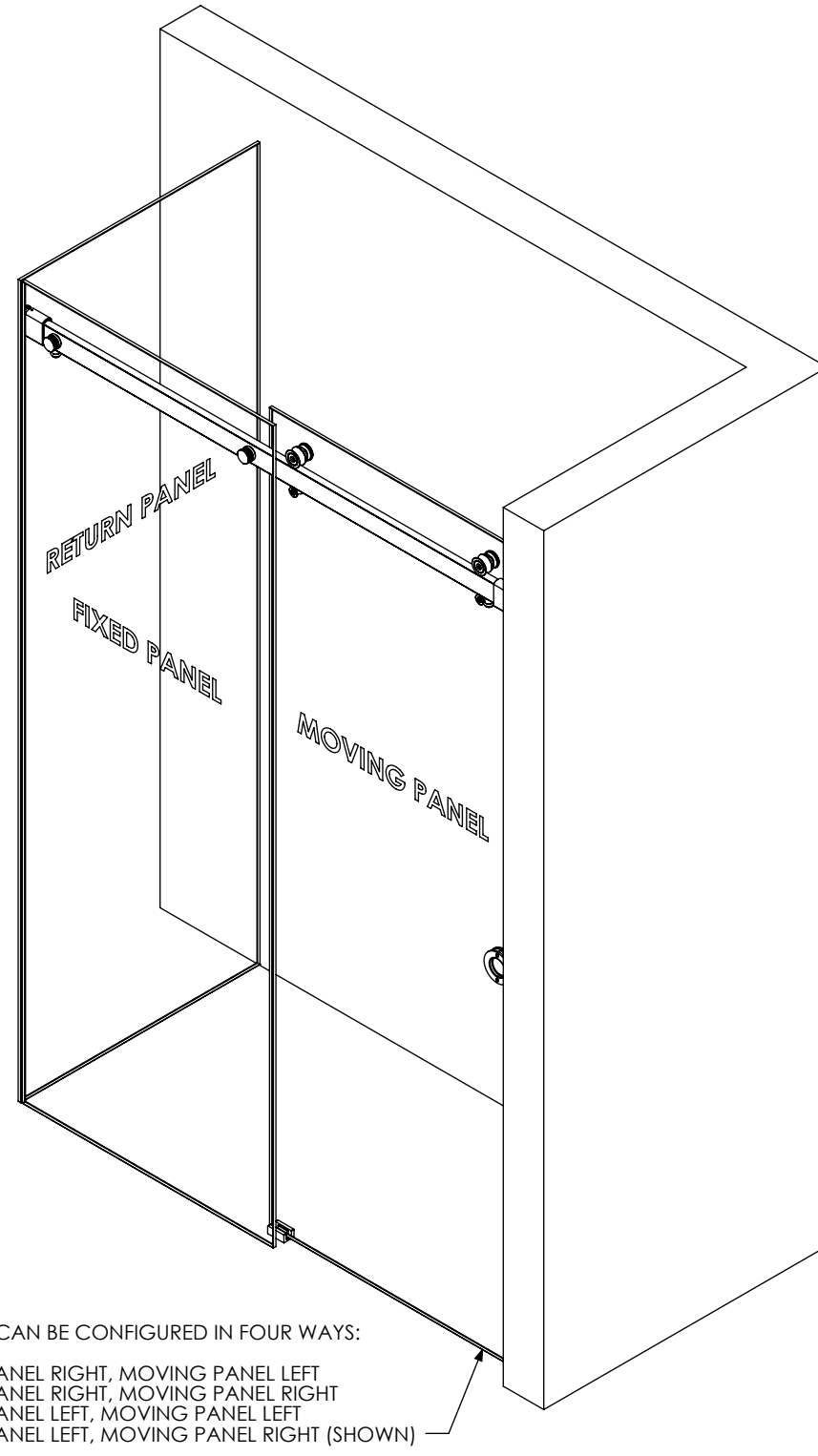

CORNER CAN BE CONFIGURED IN FOUR WAYS:
 RETURN PANEL RIGHT, MOVING PANEL LEFT
 RETURN PANEL RIGHT, MOVING PANEL RIGHT
 RETURN PANEL LEFT, MOVING PANEL LEFT
 RETURN PANEL LEFT, MOVING PANEL RIGHT (SHOWN)

CORNER GLASS THICKNESS RANGE: 3/8" To 1/2"

BYPASSING

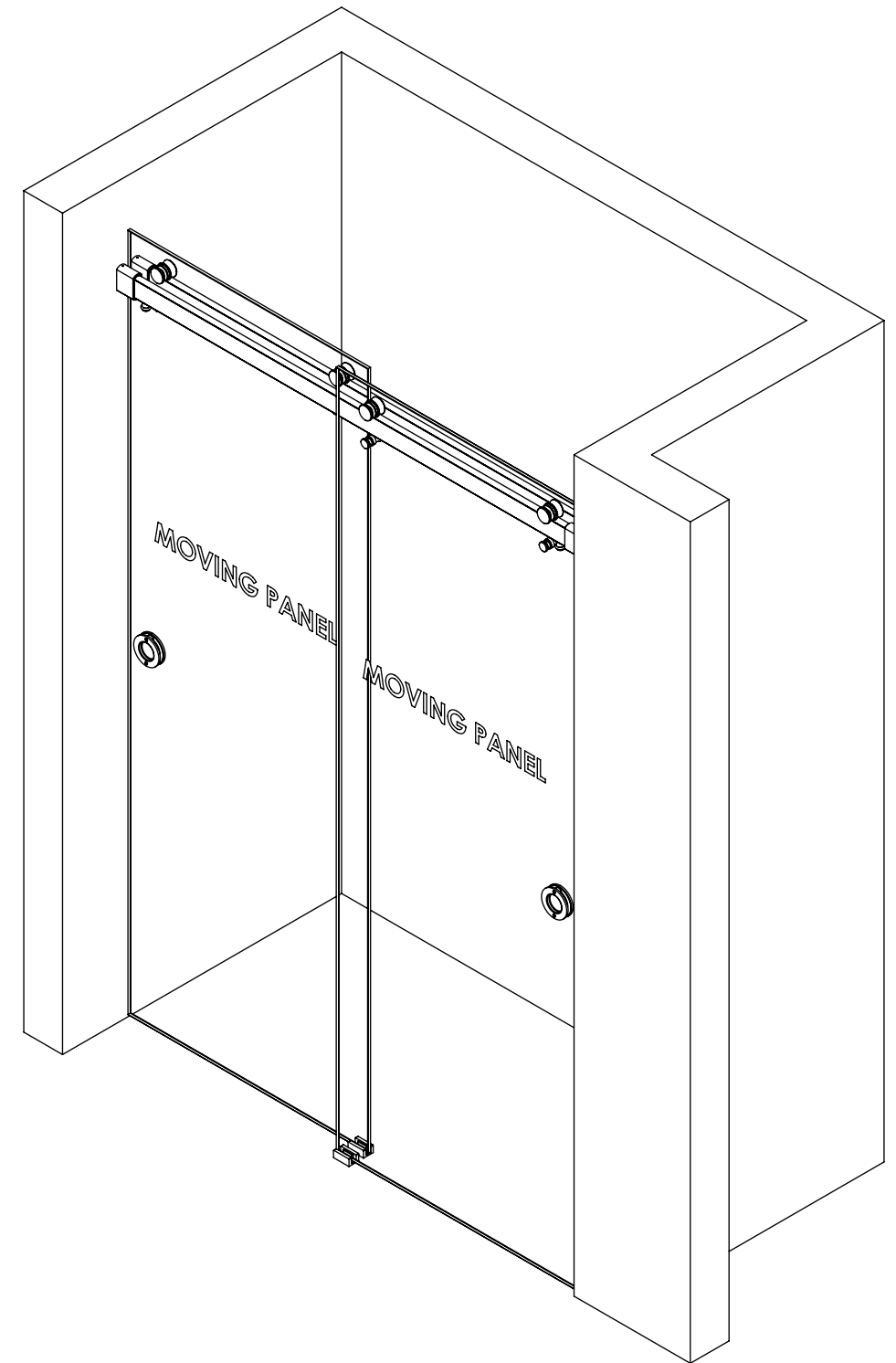

BYPASS GLASS THICKNESS RANGE: 5/16" To 1/2"

DOCUMENT: PRODUCT SPECIFICATIONS
 SYSTEM: FREYA
 MOUNTING STYLE: GLASS

DOOR APPLICATION: BYPASSING
 PANEL THICKNESS: 5/16" TO 1/2"
 MAXIMUM WEIGHT: TRACK LENGTH DEPENDENT (SEE TABLE BELOW)

DRAWING SCALE: 3/4" = 1'-0" (1:16)
 UNITS: INCHES
 DATE: 11/16/2023

KROWNLAB
 2351 NW York St.
 Portland, OR 97210
 +1 503 292 6998
 www.krownlab.com
 support@krownlab.com

KROWNLAB
 PDX - ORE

TRACK SPAN	MAX. PANEL WEIGHT
60"	125lb
72"	100lb

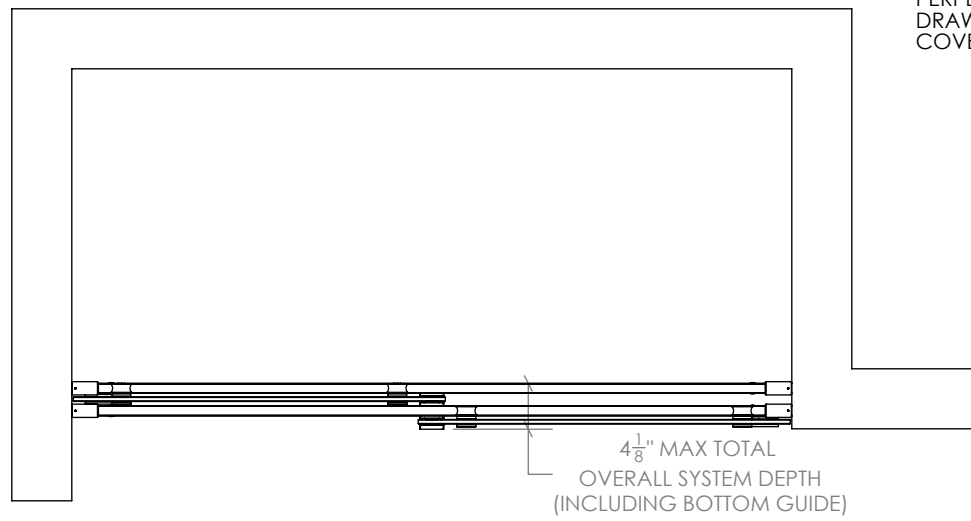
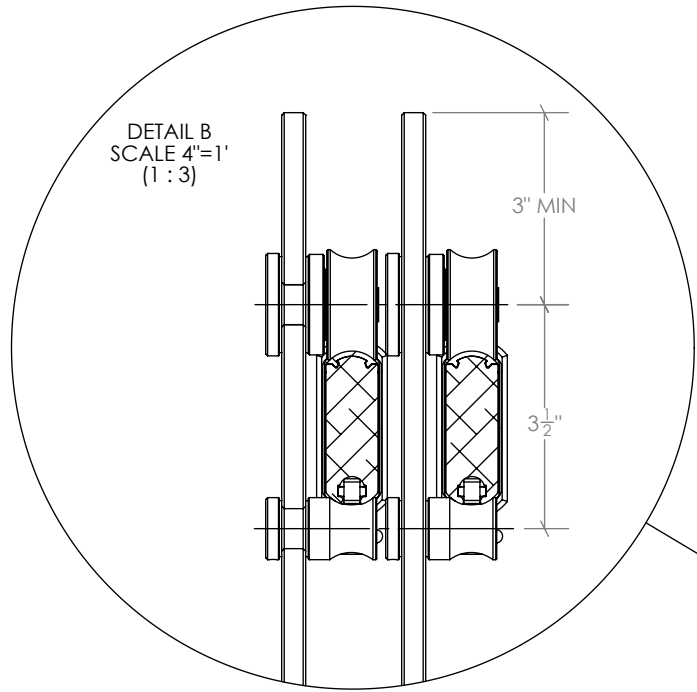

GENERIC WALL SHOWN. THE TRU-LEVEL PERPENDICULAR TRACK MOUNTING DRAWING IN THE FOLLOWING PAGES COVERS SUPPORTED WALL TYPES.

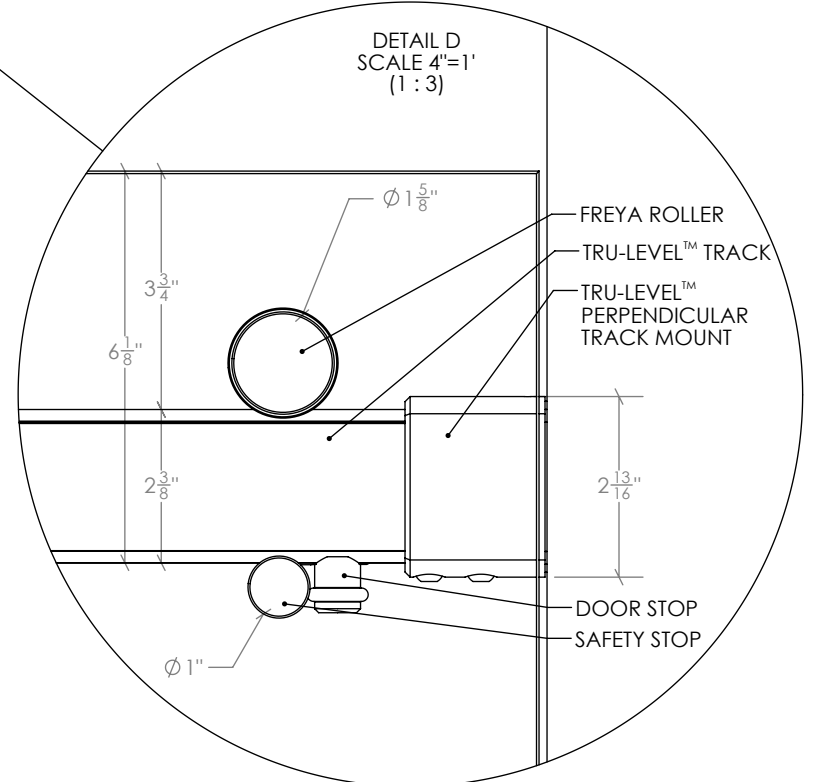
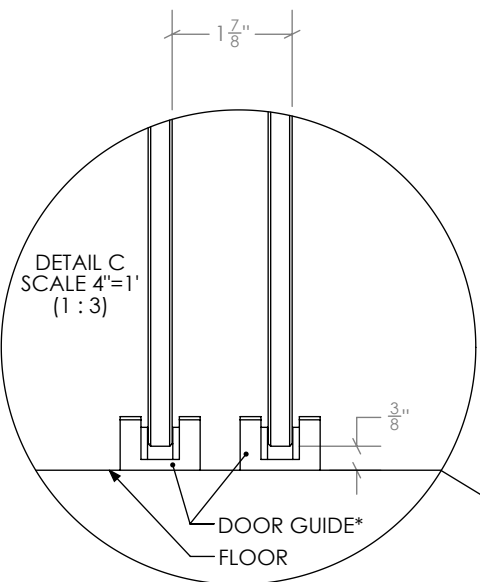
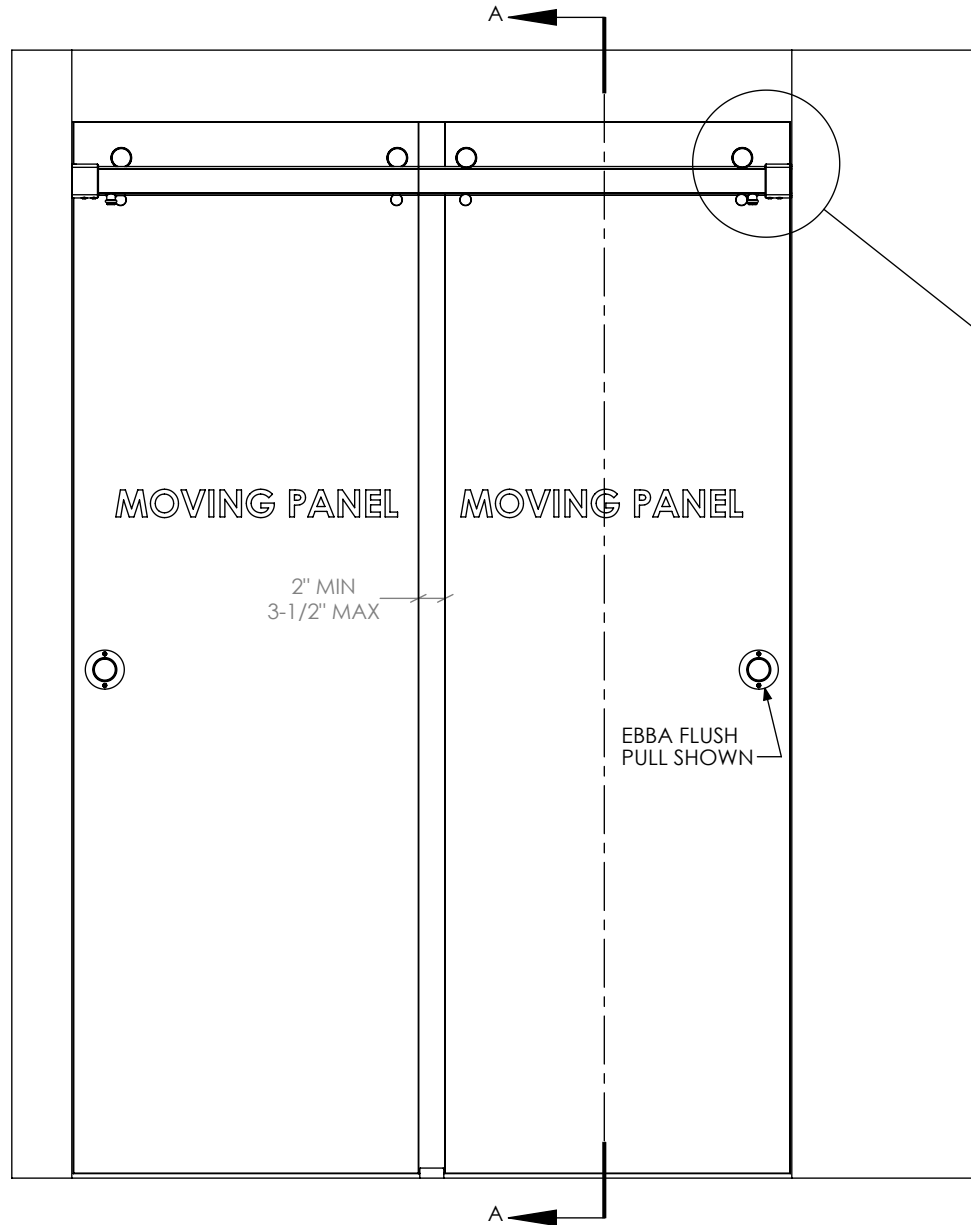
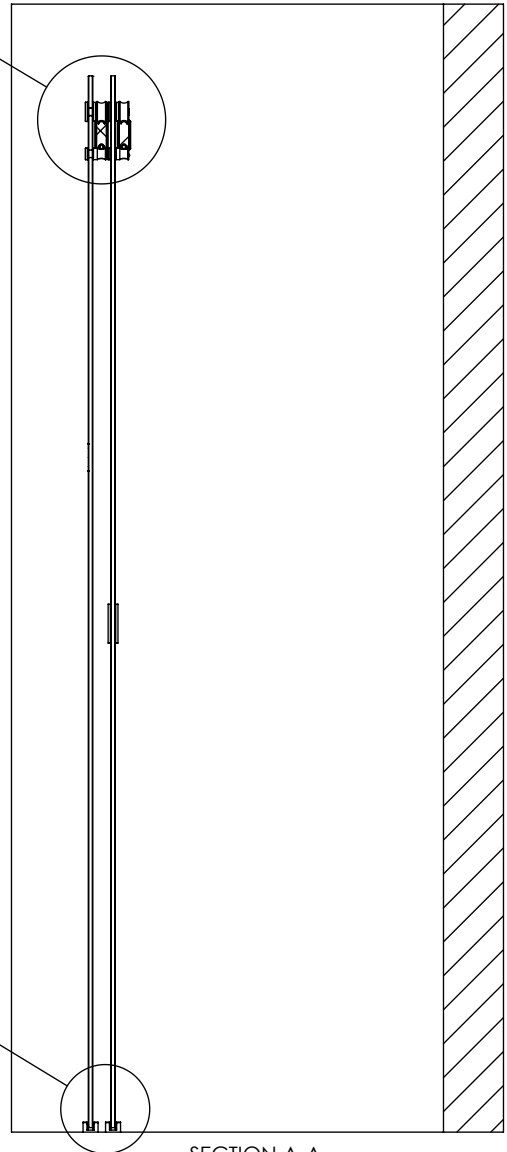
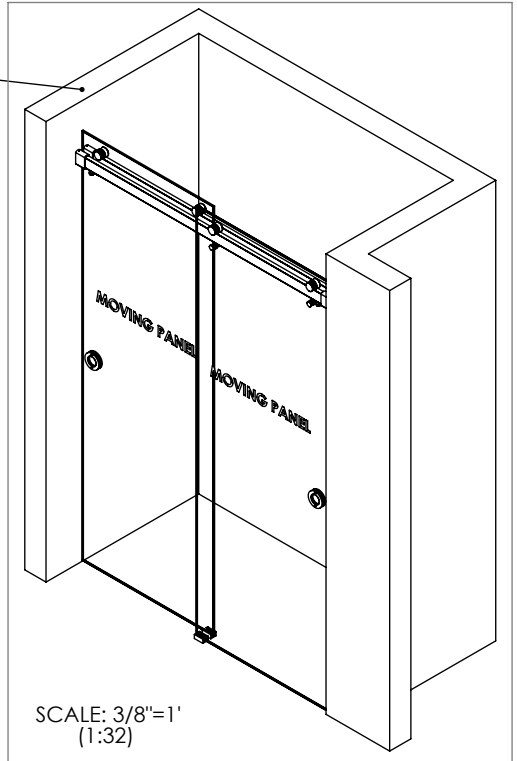

DOCUMENT:	PRODUCT SPECIFICATIONS	DOOR APPLICATION:	ALCOVE, CORNER, BYPASSING	DRAWING SCALE:	3/4" = 1'-0" (1:3)	KROWNLAB 2351 NW York St. Portland, OR 97210 +1 503 292 6998 www.krownlab.com support@krownlab.com	
SYSTEM:	FREYA	PANEL THICKNESS:	5/16" TO 1/2"	UNITS:	INCHES		
MOUNTING STYLE:	GLASS	MAXIMUM WEIGHT:	TRACK CONFIGURATION DEPENDENT	DATE:	11/16/2023		

WHAT'S INCLUDED PER DOOR PANEL:
 2 x - FREYA GLASS MOUNT TROLLEY KIT
 1 x - DOOR GUIDE KIT (DOOR GUIDE MAY DIFFER - MULTIPLE OPTIONS EXIST)
 1 x - TRU-LEVEL™ TRACK SYSTEM WITH ALL MOUNTING HARDWARE (SEE SEPARATE PAGE)

ALL GLASS PANELS AND FIXED MOUNTING HARDWARE MUST BE SOURCED THROUGH GLASS INSTALLER OR OTHER PARTY

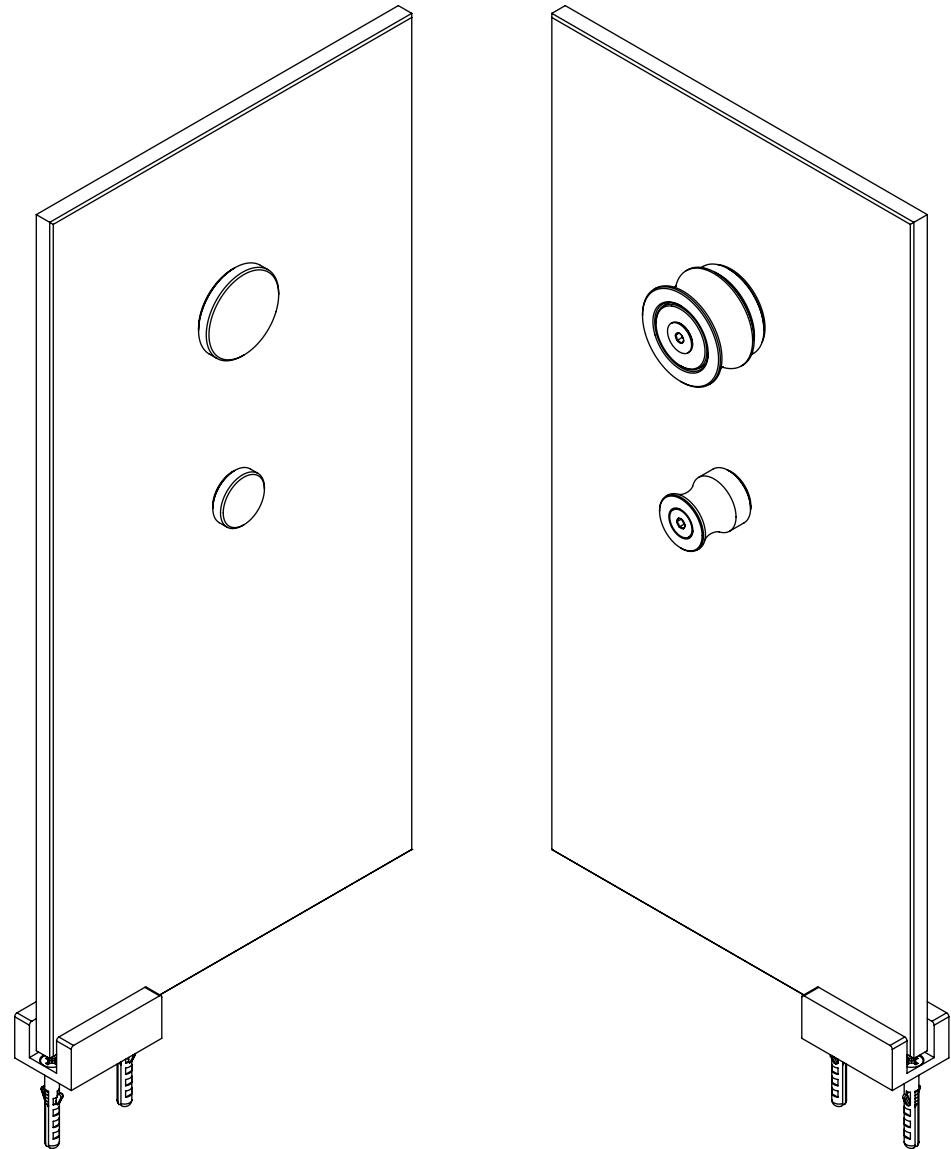

FREYA GLASS MOUNT TROLLEY KIT (x 2 INCLUDED)

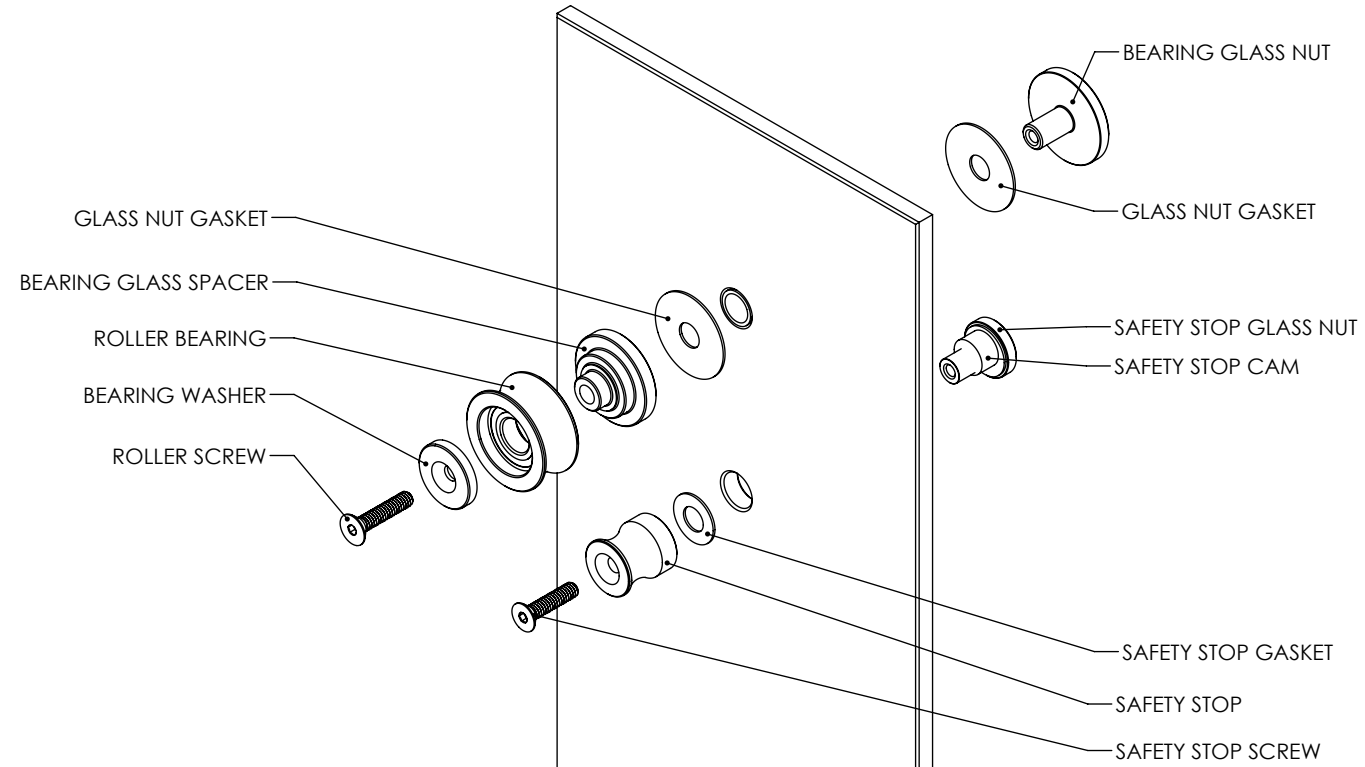

DOOR GUIDE KIT (x 1 INCLUDED*)

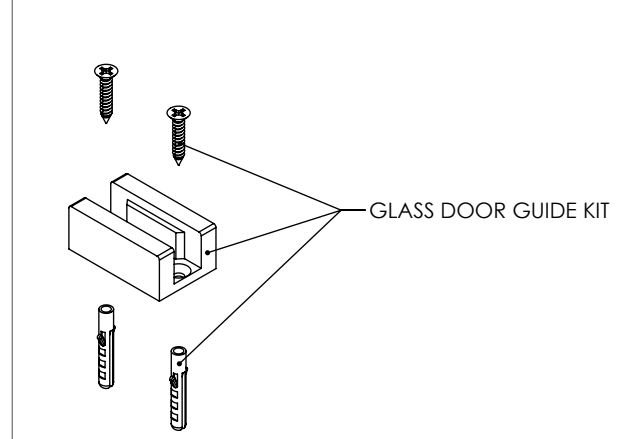

* = THE DOOR GUIDE MAY DIFFER - MULTIPLE OPTIONS EXIST

DOCUMENT: PRODUCT SPECIFICATIONS - GLASS DOOR PANEL SPECIFICATIONS	DOOR APPLICATION: ALCOVE, CORNER, BYPASSING	DRAWING SCALE: 3/4" = 1'-0" (1:12)	KROWNLAB 2351 NW York St. Portland, OR 97210 +1 503 292 6998 www.krownlab.com support@krownlab.com
SYSTEM: FREYA	PANEL THICKNESS: 5/16" TO 1/2"	UNITS: INCHES	
MOUNTING STYLE: GLASS	MAXIMUM WEIGHT: TRACK CONFIGURATION DEPENDENT	DATE: 11/16/2023	



ALL GLASS PANELS AND FIXED MOUNTING HARDWARE ARE TO BE SOURCED THROUGH GLASS INSTALLER OR OTHER PARTY, AND MUST MEET THE FOLLOWING REQUIREMENTS:

GLASS PANELS MUST BE FLAT POLISHED AND HAVE A 1MM CHAMFER ON ALL EDGES.

ALL HOLES MUST BE DRILLED OR CNC MACHINED WITH STRAIGHT WALLS AND SEAMED EDGES. DO NOT WATER-JET - NO TAPERED HOLES.

ALL TEMPERED GLASS IS SUBJECT TO EXPERIENCE SPONTANIOUS BREAKAGE. IT IS THE BUYERS RESPONSIBILITY TO DETERMINE AND APPROVE GLASS SPECIFICATION(S) SUITABLE TO MEET ALL FACTORS RELEVANT TO THEIR PARTICULAR USE OR APPLICATION IN CONJUNCTION WITH ALL KROWN LAB, INC.'S PRODUCTS.

REFERENCE ASTM C1048, 7.9.5

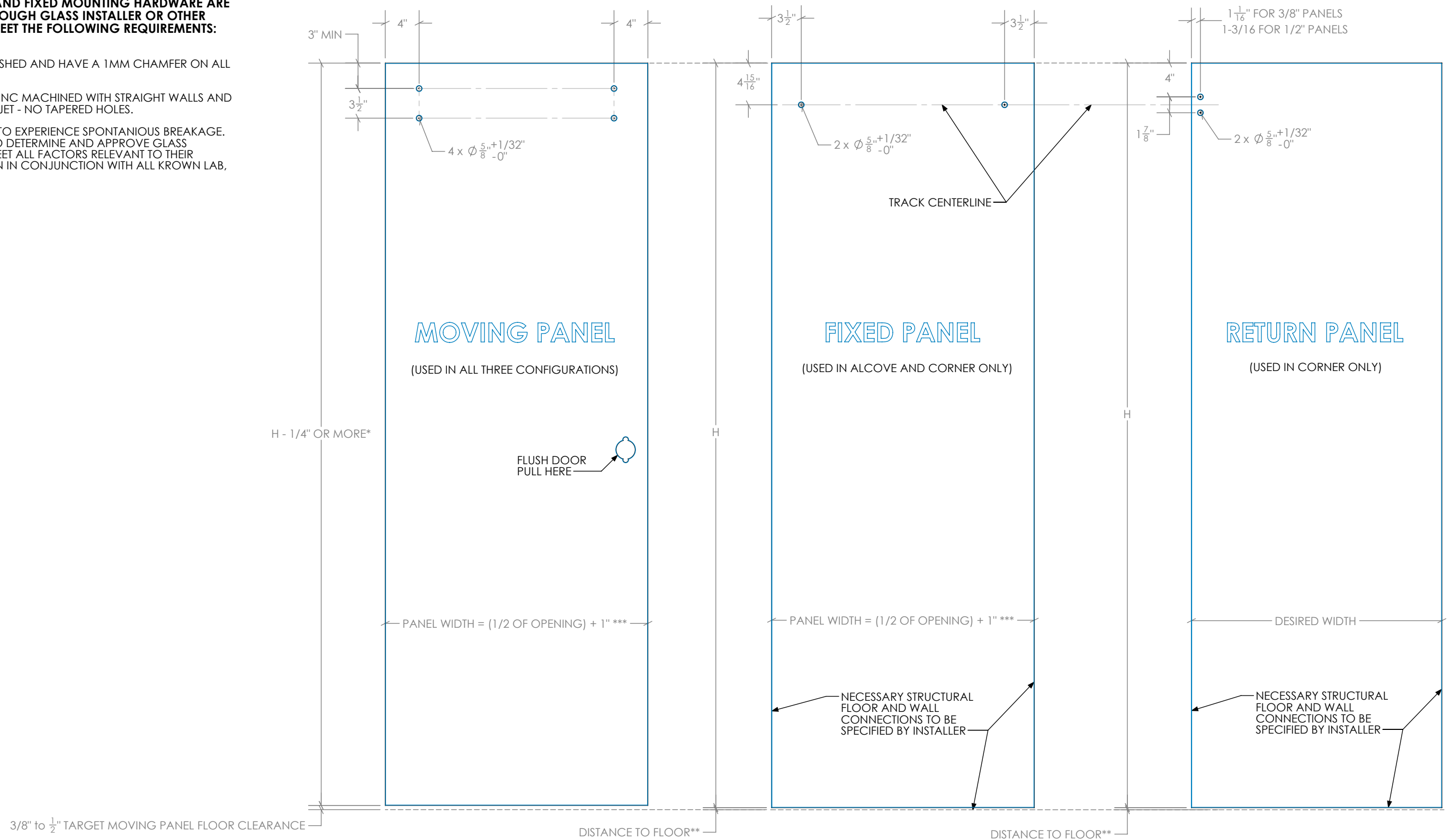

* = 1/4" IN FORMULA ASSUMES FIXED AND RETURN PANELS STRUCTURALLY SECURED 1/8" TO 1/4" OFF FLOOR.

** = DISTANCE TO FLOOR TO BE DETERMINED BY INSTALLER BASED ON CHOSEN STRUCURAL FLOOR CONNECTIONS.

*** = THE PANEL WIDTH FORMULA CREATES A 2" OVERLAP, NOT ACCOUNTING FOR NECESSARY WALL AND PANEL CLEARANCES. WIDTH PROPORTIONS ARE BASED ON NON-PROTRUDING DOOR PULLS. PROTRUDING DOOR PULLS ARE NOT COMPATIBLE WITH BYPASSING AND REQUIRE SPECIAL CONSIDERATION.