

INSTALLATION INSTRUCTIONS

PRODUCT: BALDUR + ODEN

CONFIGURATION: SINGLE DOOR
MOUNT: TOP MOUNT

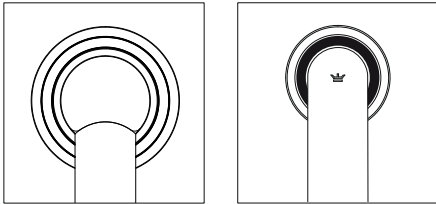

To deviate, or to not comprehensively and precisely follow all Krown Lab, Inc provided specifications and installation instructions can result in unsafe or hazardous site conditions that can cause bodily harm or death.

Product is covered by U.S. patents. For more information visit www.krownlab.com

I. TOOLS + MATERIALS REQUIRED

TOOLS

- Tape measure
- Imperial allen wrench kit
- Level
- Ratchet with 1/4" , 3/8" and 1/2" sockets
- Torque wrench capable of measuring 110inlbs(9.5ftlbs)
- #2 Philips screw driver
- Power drill
- One or more of the following drill bits depending on product configuration:
 - 13/64" metal drill bit for multiple-track systems
 - Appropriate drill bits for pre-drilling holes for the provided wood screws
- #3 Philips driver and extension for impact driver OR a long-handled #3 Philips screw driver.

TOOLS FOR DRILLING AND CUTTING TRACK

- Miter saw and carbide toothed blade
- 1/2" to 11/16" metal drill bit for track (11/16" holes provide full 1/4" adjustment in any direction)

MATERIALS

- Blue painters tape
- Pencil or other non permanent marking tool

2. VERIFY ALL COMPONENTS

BASE KIT

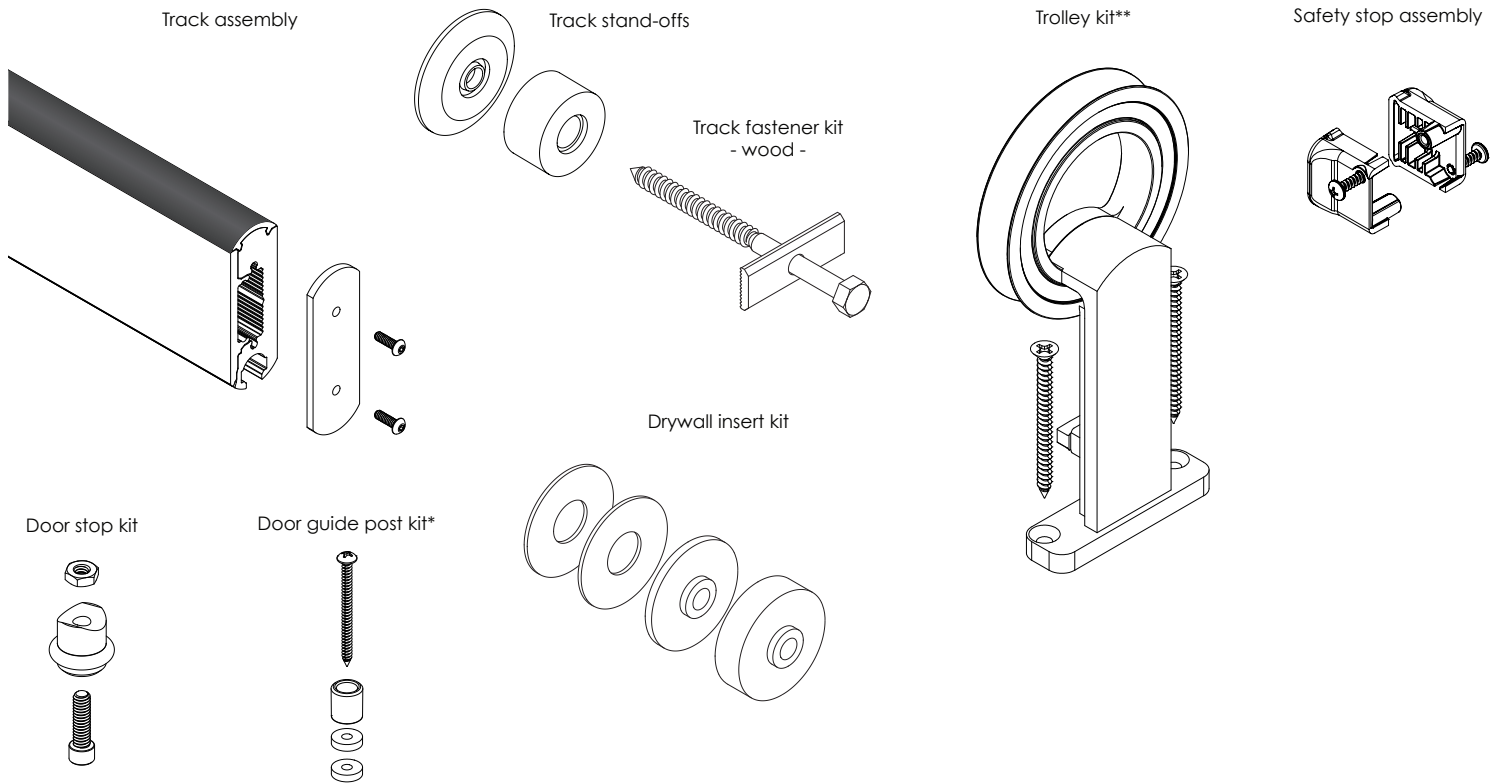

*Door guide included may differ.

** Illustration is based on Baldur

SYSTEM OPTIONS AND ADDITIONS

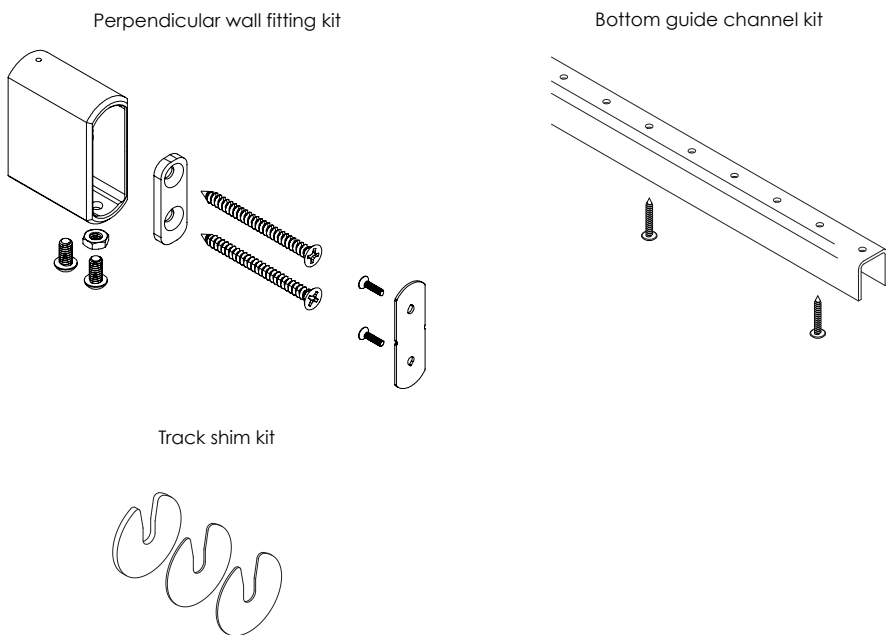

Go to our website for a complete range of door pulls and locks.

3. REMOVE TRACK COVER

- ① Remove the track from the protective sleeve.
- ② Gently pry the cover from the base with a slender plastic (non-marring) tool.

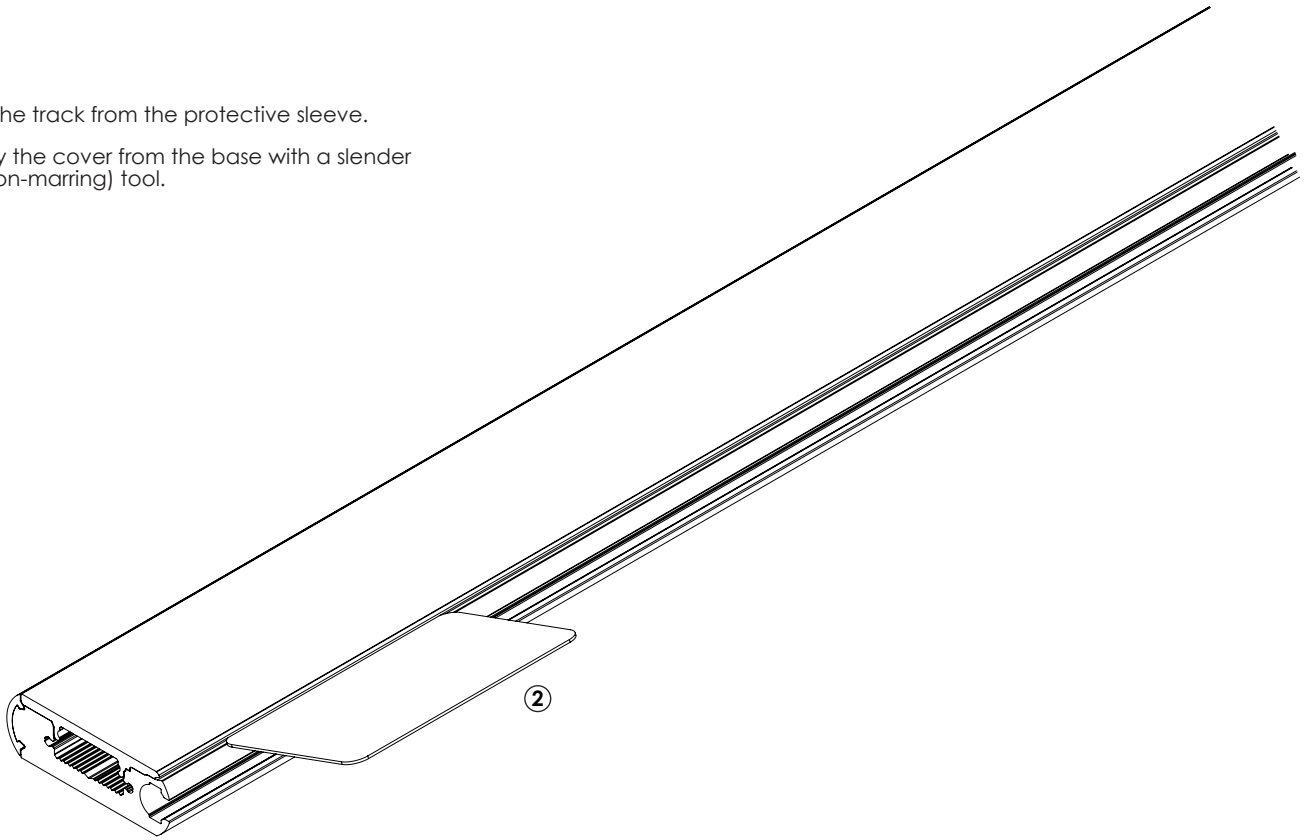

4. LOCATE TRACK ATTACHMENT POINTS

- ① Determine the height of the track centerline:
 $HEIGHT = DOOR\ PANEL\ HEIGHT + 3"$
This will result in approximately 3/8" of clearance between your door panel and the floor. Adjust if desired or necessary.
- ❗ Add 3/4" to this dimension if you are using the optional bottom guide channel.
- ② Mark the track centerline on your wall. (If you run a length of painter's tape along your wall, you'll thank us later!)
- ③ On the wall, mark the desired location of the end point of your track, ideally so that it aligns with the edge of your door panel in the desired closed position.
- ④ Determine and mark the locations of all mounting points along the track centerline. If your track was pre-drilled, simply transfer the hole pattern from the track to the wall. If you purchased an un-drilled track, see step 5.
- ❗ Krownlab hardware requires a structural wall to function properly and safely. Each mounting point must engage an appropriate amount of structural material: Wood or metal framed walls must have 3" of solid blocking secured to studs or other framing members.

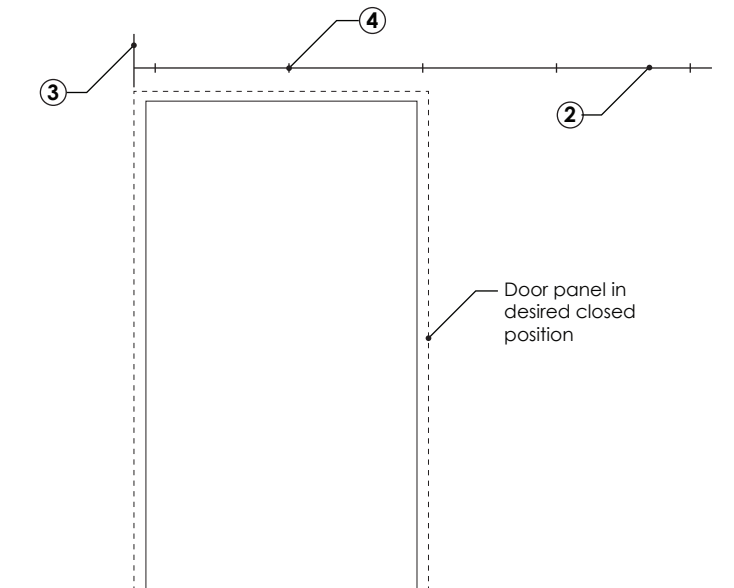

5. OPTIONAL STEP - UNDRILLED TRACK

If your track is undrilled, please refer to the included instructions to drill the track properly for the weight of your panel.



6. LINK MULTIPLE TRACKS

Track Connectors are included with multiple-track systems to keep the tracks in alignment. Skip to the next step for single-track installations.

- ① Butt tracks end to end as they will be installed on your wall. Using the track connector washer plate centered over the seam between the tracks as a template, mark each track for drilling.
- ② Drill a 13/64" hole in each track.
- ③ Connect tracks by assembling the track connector washer plate as shown. Ensure that washer teeth align with teeth in the track before tightening fasteners.
- ④ Install a 3/8" socket onto a torque wrench and torque the nuts to 48 inch-lbs (4 ft-lbs). You may need to use a 1/8" allen wrench to prevent the screws from rotating while torquing.

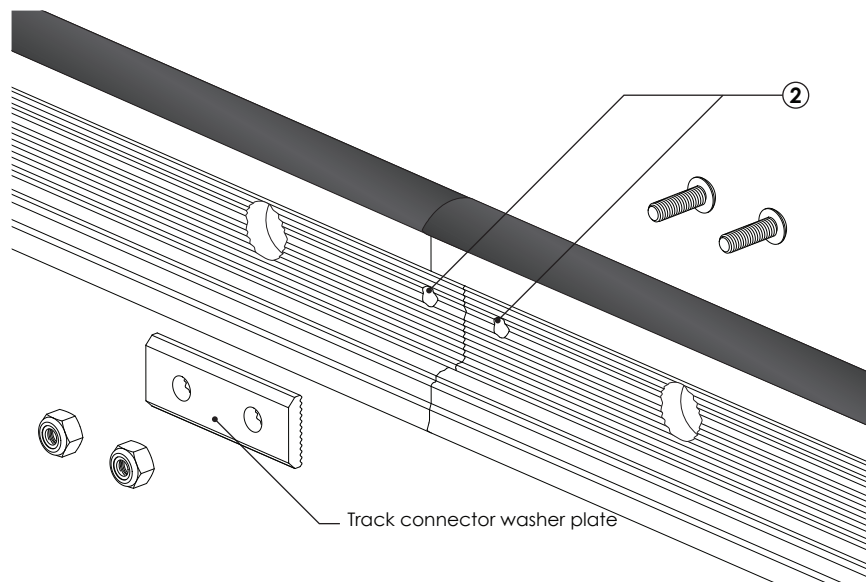
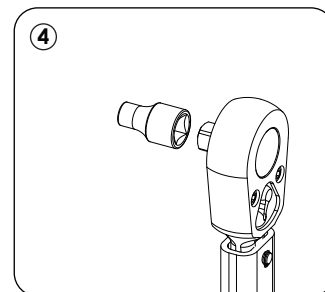

7. INSTALL DRYWALL INSERTS

This step is for walls with a non-structural surface only. I.e., drywall, pin-up board or other materials that are weaker than the wood blocking behind them. Skip to the next step for installations without these materials.

- ① Use a 1-3/4" spade bit to remove the drywall at each mounting point.
 - ② Place a drywall insert into each drywall cavity.
- ❗ To perform their function, drywall inserts must be up against the structural material of your wall and flush with the finished surface of the drywall. If needed, use the included steel shims as shown.

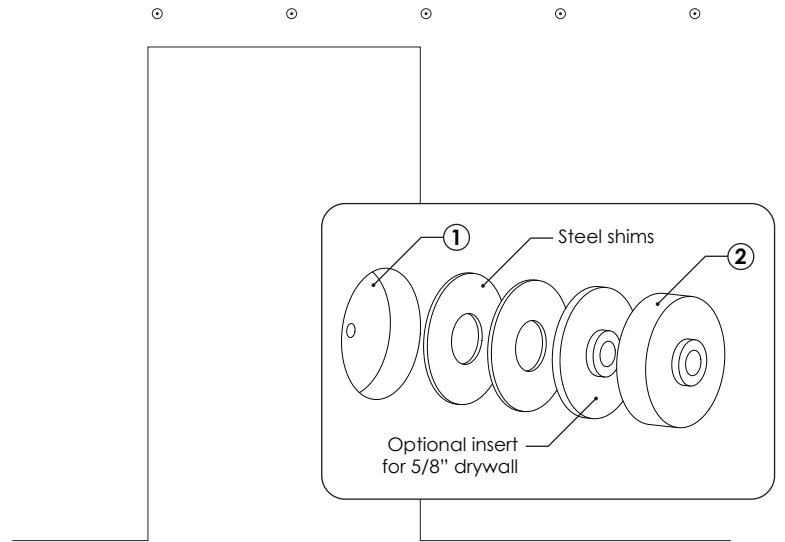

8. PREDRILL STRUCTURAL WALL

- ① Drill a pilot hole for each mounting point.
- ❗ Make sure that each mounting point engages an appropriate amount of structural material: Wood or metal stud framed walls must have 3" of solid wood blocking secured to studs or other framing members.

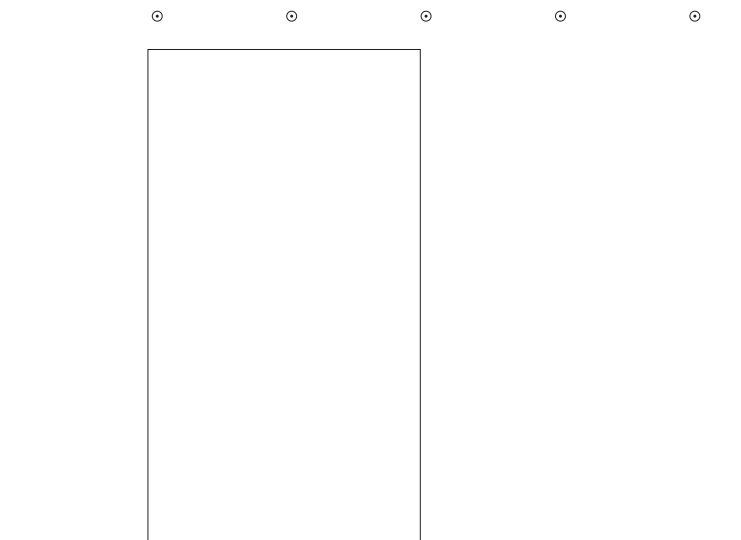

Structural requirements and suitability of other wall conditions to be determined by contractor or other qualified professional.

9. DETERMINE DESIRED WALL CLEARANCE

- 1 Taking baseboard and door frame into consideration, determine if you need to use the optional track stand-off based on the wall clearance dimensions at right.

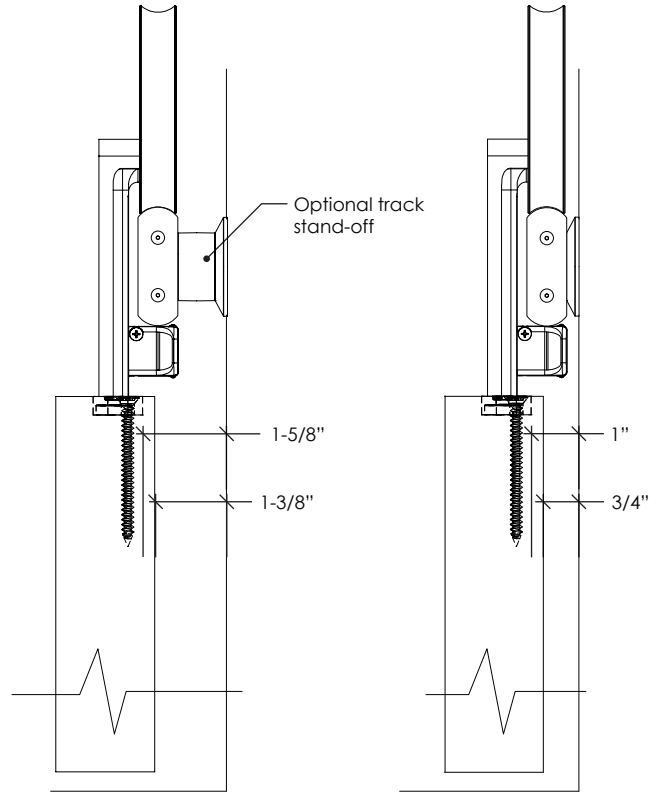
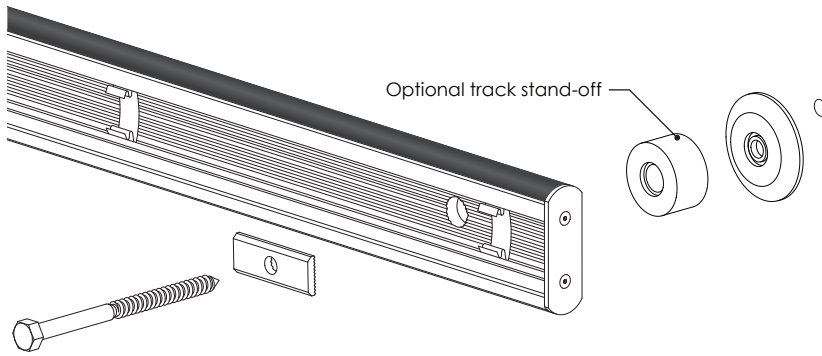

10. ATTACH DOOR STOPS

- 1 If installing Premium Door Stops, reference those installation instructions in parallel.

- 1 Temporarily slide one door stop to each end of the track. Snug, but do not tighten the stops yet.

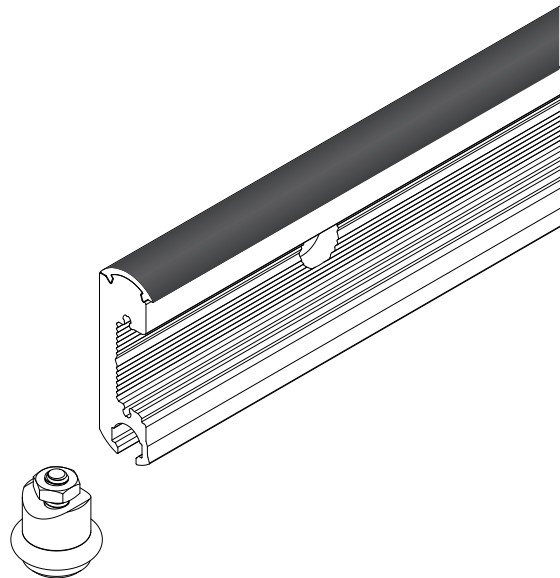

11. OPTIONAL STEP - INSTALL PERPENDICULAR WALL FITTING

If your order included a perpendicular track attachment, please proceed to the separate installation instructions to install the fitting. Once complete, resume the next step in these instructions.

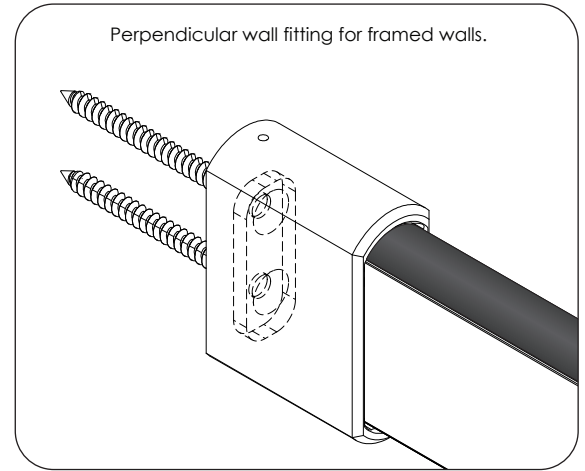
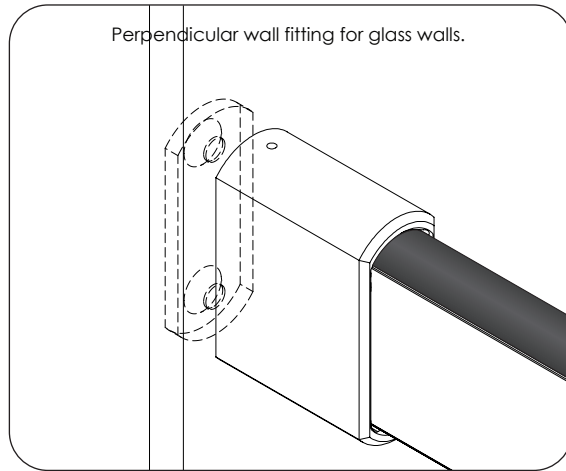

12. INSTALL END CAPS

End cap assembly may vary at each end of the track.
Select the scenario below that best matches the track configuration:

- No perpendicular wall fittings – follow the steps below for each end.
- Perpendicular wall fitting on one end – follow the steps below for the opposite end.
- Perpendicular wall fittings on both ends – the track was completed in the previous step. Proceed to the next step in these instructions.

- ① Use the provided fasteners and a 1/16" allen wrench to gently secure the end cap to the track. Do not over-tighten!
- ② Repeat on the other end of the track, if applicable.

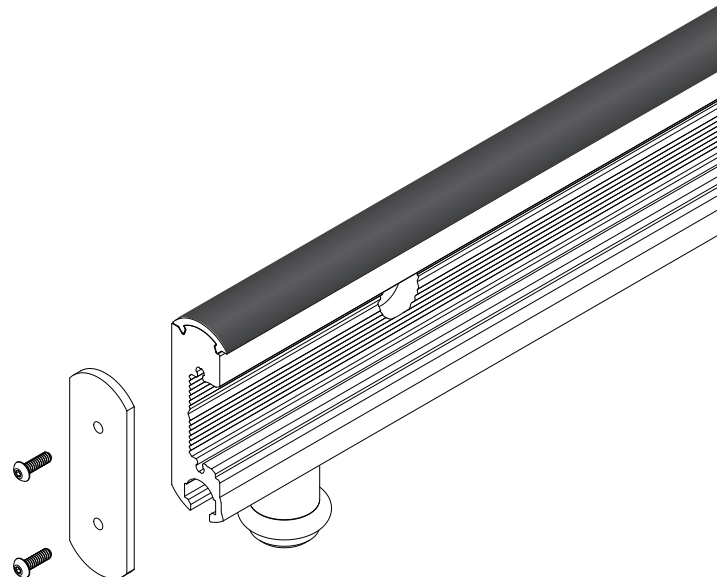

13. MOUNT TRACK TO WALL

- ① Slide springs to the ends of track, but keep 1" away from holes to prevent clamping a spring under track washer plate. Evenly space springs along the length of track to ensure the cover is well-retained.
- ② Ensuring that the black plastic track cap faces up, loosely install one end of your track with the appropriate track spacers and hardware.
- ③ Repeat with the opposite end of the track.
- ⚠ Support the track assembly along its length if multiple tracks are linked together.
- ④ With both ends of the track now supported, loosely install the remaining mounting points.

⚠ Krownlab provides a range of track fasteners for different typical wall conditions. Lags for walls with wood blocking illustrated here. Contractor or other qualified professional to ensure suitability of provided fasteners for site-specific conditions.

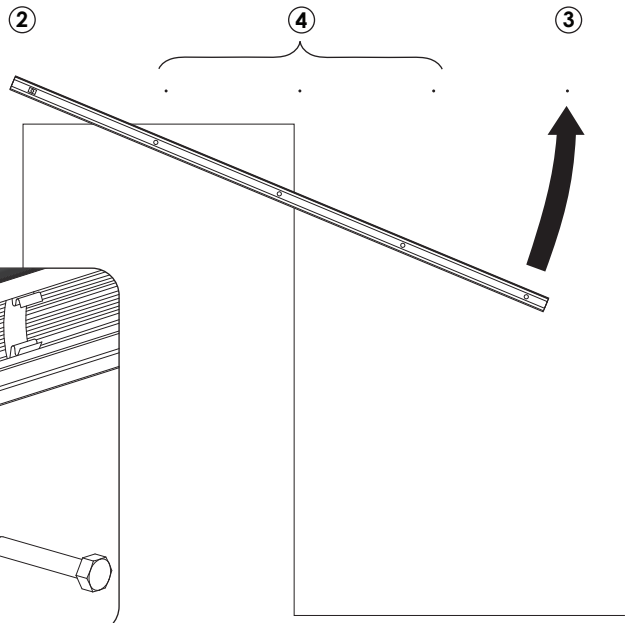
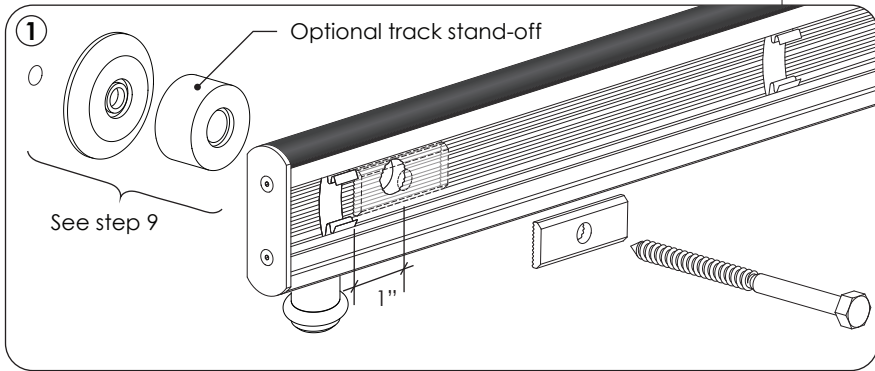

14. LEVEL AND ADJUST TRACK HEIGHT

- ① Snug, but don't yet tighten each track fastener starting at the center and moving toward the ends. For maximum adjustability, start by positioning the washer plate in the center (neutral) position.
- ⚠ Be sure to account for sloped or uneven floor when setting track height.
- ② Use the Tru-Level™ System to make sure track is level: adjust the position of the washer plate at each mounting point until track is level.
- ⚠ Ensure that washer teeth align with teeth in the track before tightening fasteners.

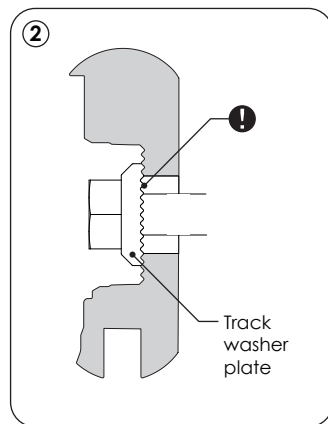
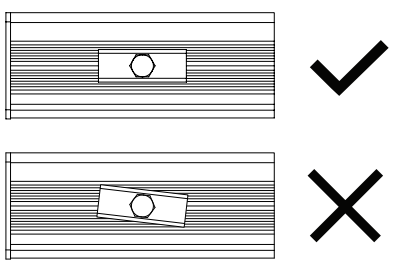
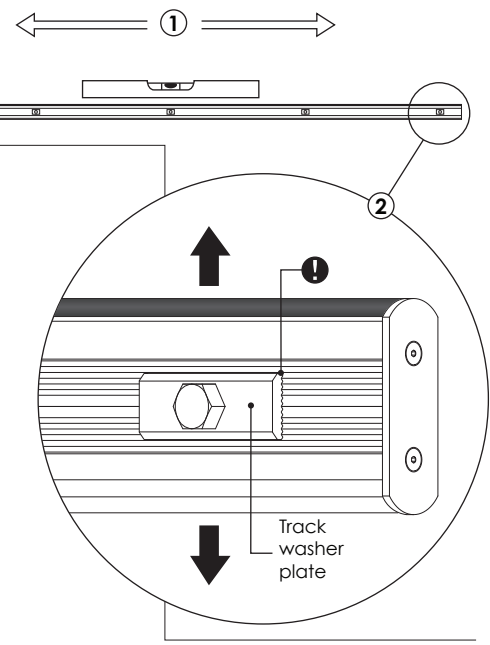

15. OPTIONAL STEP - INSTALL TRACK SHIMS

- ① Sight down the length of your track to determine if unevenness in the wall is causing your track to bow. If necessary:
- ② Loosen track attachment points as needed and insert shims from below. Ensure that the opening of the shim faces up. Start with one of the thinner shims, adding and swapping shims as needed until the track is straight to within the thickness of one shim.
- ⚠ Never use more than one shim kit at any mounting point. Track shims may only be used at mounting points that pull the track out of true.

NOTE: Bowing in the track will negatively affect the performance of the entire system, causing increased friction and excessive wear on some components. Krownlab's warranty does not cover wear caused by improper installation.

Optional track stand-off

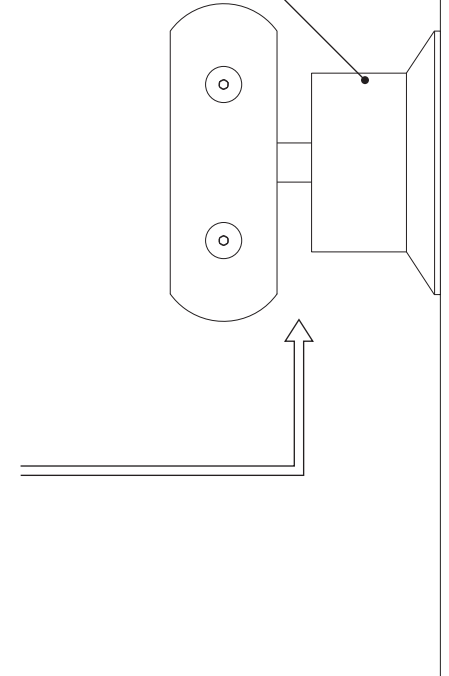

Do not use shims with the purpose to extend the track standoff distance.

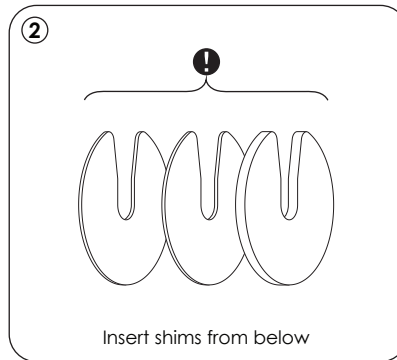

16. SECURE TRACK TO WALL

- ① Confirm the track has been leveled, shimmed, and all mounting points have been securely fastened.
- ② Inspect each track spring to ensure they are not interfering with the mounting hardware and evenly spaced along the length of the track.
- ③ Tighten all track lag bolts.
- ④ Carefully reattach the track cover.
- ⑤ Confirm the track cover is fully seated and securely attached along the length.
- ⚠ Ensure that the arrow on the inside of the track cover is facing up.

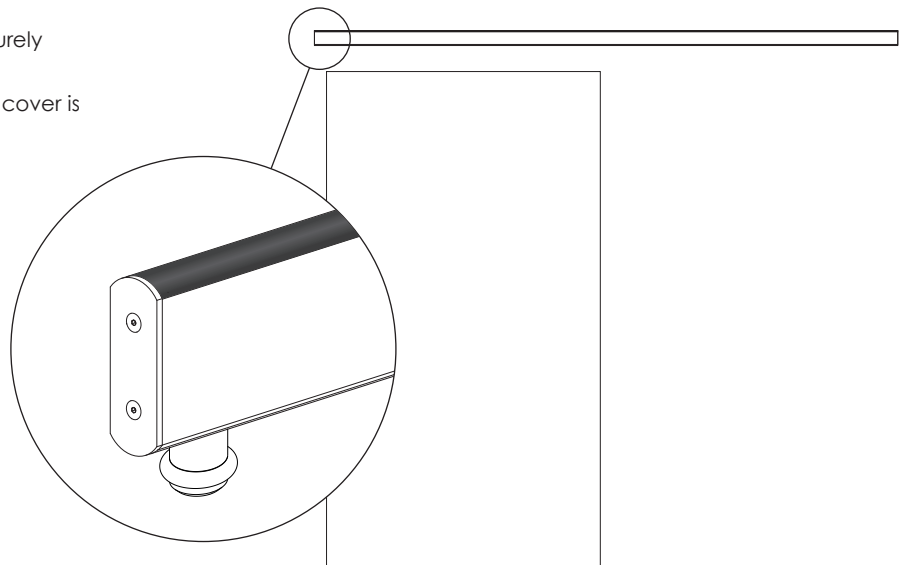
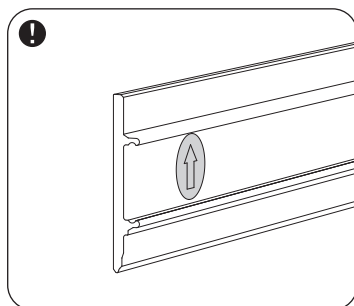

17. PREPARE DOOR FOR DOOR GUIDE

Refer to the separate installation instructions for the door guide that is included with your order*. Once door is prepared, return to this document for next steps.

*Included door guide may vary from examples shown below.

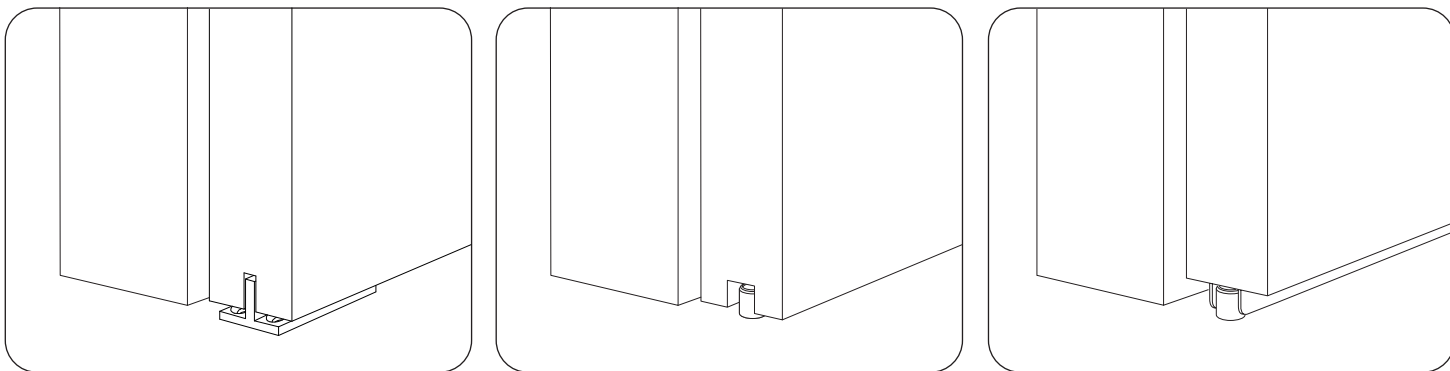

Installation of a door guide is required, and must always be engaged for safety.

18. ROUTE DOOR PANEL

- 1 Route the top of the door panel to accept the trolleys as shown.
- 2 Also prep for, but do not yet install, your door pulls or other door hardware.
- 3 Adjust location of recess to achieve the right door panel clearance from wall and door trim. Minimum dimension is driven by door panel material.



Screws should only be installed into the door top horizontal rail.

Top rail of the door should be structural and be able to support the weight of the door panel.

All screws should engage the horizontal grain of the top rail, not the end-grain of the vertical stile.

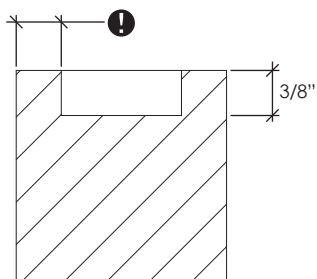
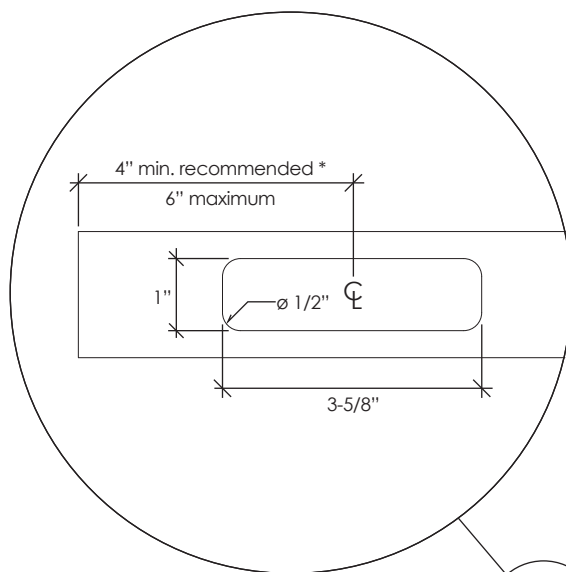

* Facilitates easier door guide post installation in step 21.

19. ATTACH TROLLEYS TO DOOR PANEL

- ① Pre-drill and attach the trolleys using the fasteners provided. Make sure that the trolleys are secured parallel to the face of the door panel
- ② Carefully hang your panel.
- ⚠ Do not yet install your door pulls or other door hardware.

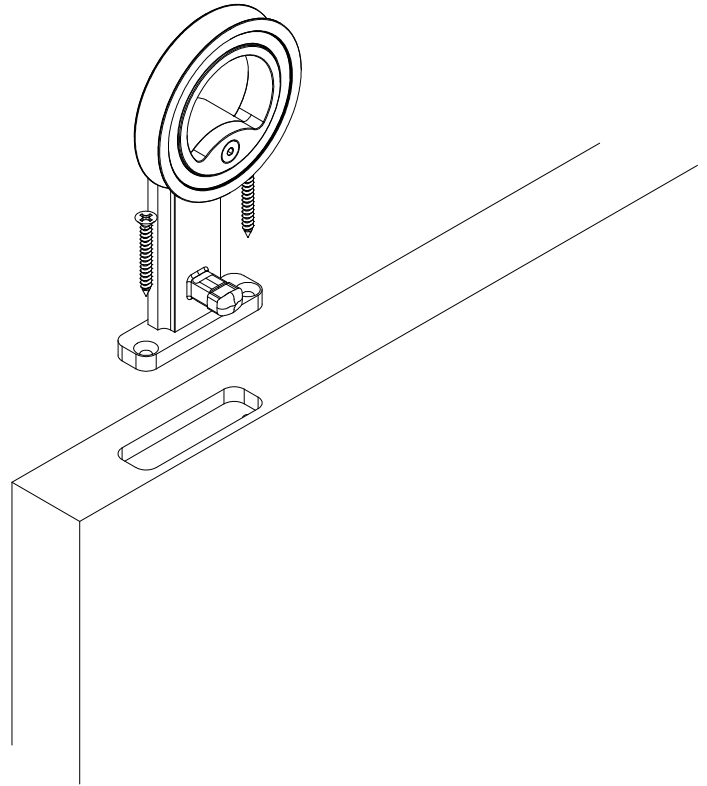

20. INSTALL SAFETY STOPS

- ⚠ If installing Premium Door Stops, reference those installation instructions in parallel.

- ① Remove protective cap from trolley post.
- ② Place one safety stop on the trolley post.
- ⚠ Ensure the safety stop is fully seated and properly aligned so this half of the post is completely covered by the safety stop.
- ③ Slide the second safety stop over the other side of the post.
- ⚠ Ensure that both safety stops are aligned and fully seated.
- ④ Thread provided screws into both sides of the safety stops using a #2 Phillips Screw Driver and lightly tighten.
- ⑤ Repeat above steps for second trolley.

NOTE: Please keep the protective cap and reuse when removing and re-hanging panel to prevent damage to your track.

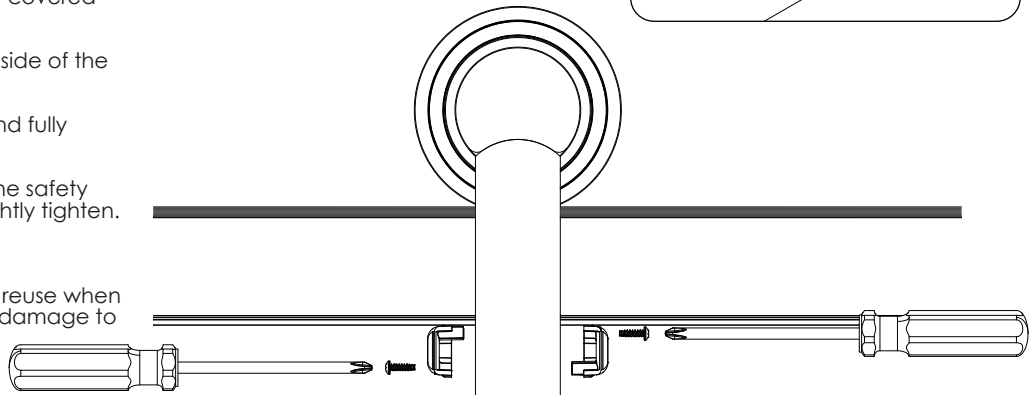
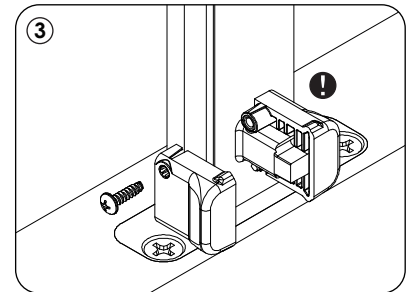

Not following the above instructions can cause a hazardous condition. Installation with both screws is mandatory.

21. INSTALL DOOR GUIDE

Refer to the separate installation instructions for the door guide that is included with your order*. Once installed, return to this document for next steps.

*Included door guide may vary from examples shown below.

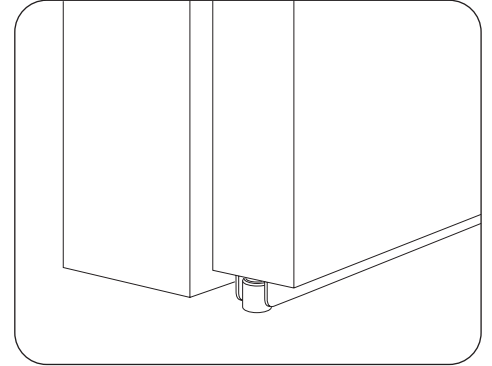
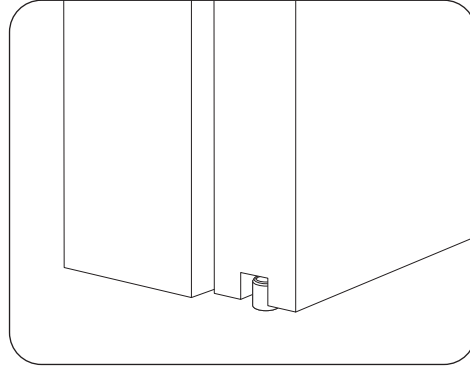
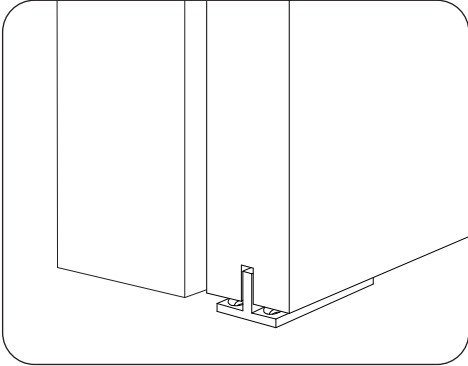

Installation of a door guide is required, and must always be engaged for safety.

22. INSTALL DOOR PULLS

- ① If applicable, install door pulls following applicable installation instructions.

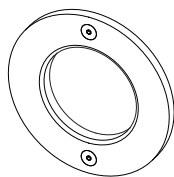

23. SET DOOR TRAVEL

❗ If installing Premium Door Stops, reference those installation instructions in parallel.

- 1 With the door in the desired closed position, slide the door stop so that it touches the safety stop of the nearby trolley.
- 2 Repeat with the door in the open position, sliding the door stop so that it touches the safety stop of the nearby trolley.
- 3 Verify that the door guide is properly engaged in the fully open and fully closed positions.
- 4 Tighten the door stops in place by hand with a 3/16" allen wrench.
- 5 Confirm locations haven't shifted while tightening. Adjust if needed.
- 5 Insert a 3/16" hex bit into a 1/4" socket on a torque wrench, and torque to 110 inch-lbs (9.5 ft-lbs).

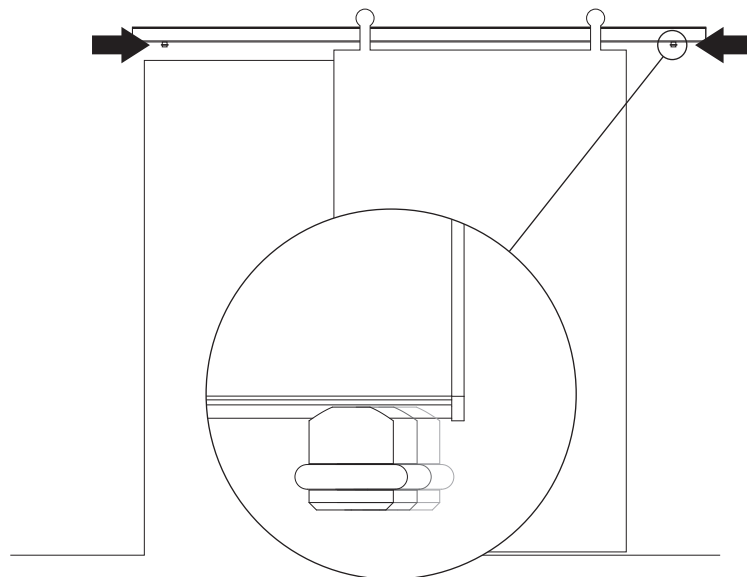
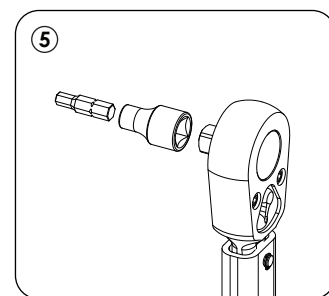

24. CARE AND MAINTENANCE

- ❗ Krownlab products require routine care and maintenance. Read and understand these requirements in our Product Care & Maintenance guide.
- 1 Thoroughly clean product and remove all debris and fingerprints immediately after installation as described in our Product Care & Maintenance guide.
- 2 Enjoy your exceptional new Krownlab Sliding Door System.