

INSTALLATION INSTRUCTIONS

PRODUCT: BALDUR

CONFIGURATION: SINGLE DOOR

TROLLEY: FACE MOUNT

TRACK MOUNT: WALL

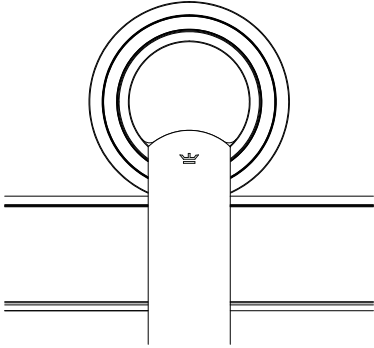

The corresponding Product Specification document is to be comprehensively reviewed prior to product installation takes place.

To deviate, or to not comprehensively and precisely follow all applicable product specifications and installation instructions can result in unsafe or hazardous site conditions that can cause bodily harm or death.

Krownlab products are covered by U.S. patents and trademarks. For more information visit www.krownlab.com

I. TOOLS + MATERIALS REQUIRED

TOOLS

- Tape measure
- Imperial Allen wrench and bit set
- Level
- Stud finder
- Ratchet and Imperial socket set
- Torque wrench capable of measuring up to 110 inch-lbs (9.5 ft-lbs)
- #2 and #3 Philips screw drivers
- Power drill
- Imperial drill bit index and countersink bit
- 1-3/4" Forstner drill bit, or similar.
- Router with grooving bit (for orders including wood door panels only)

TOOLS FOR DRILLING AND CUTTING TRACK

- Miter or chop saw and carbide toothed blade
- 9/16" metal drill bit

MATERIALS

- Blue painters tape
- Pencil or other non permanent marking tool

2. VERIFY ALL COMPONENTS

BASE KIT

Quantity included of each item is specific to ordered product configuration.

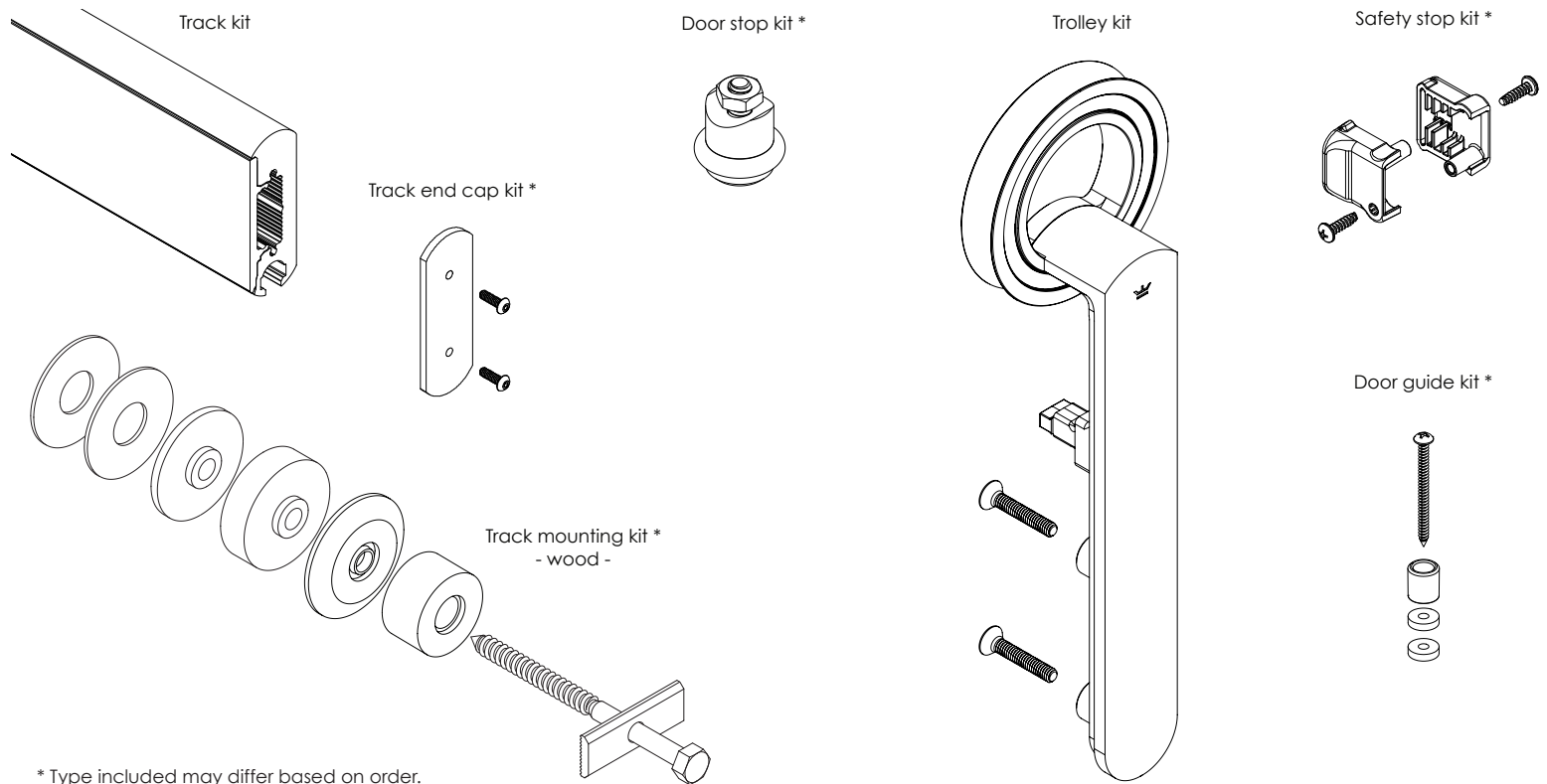

SYSTEM OPTIONS AND ADDITIONS

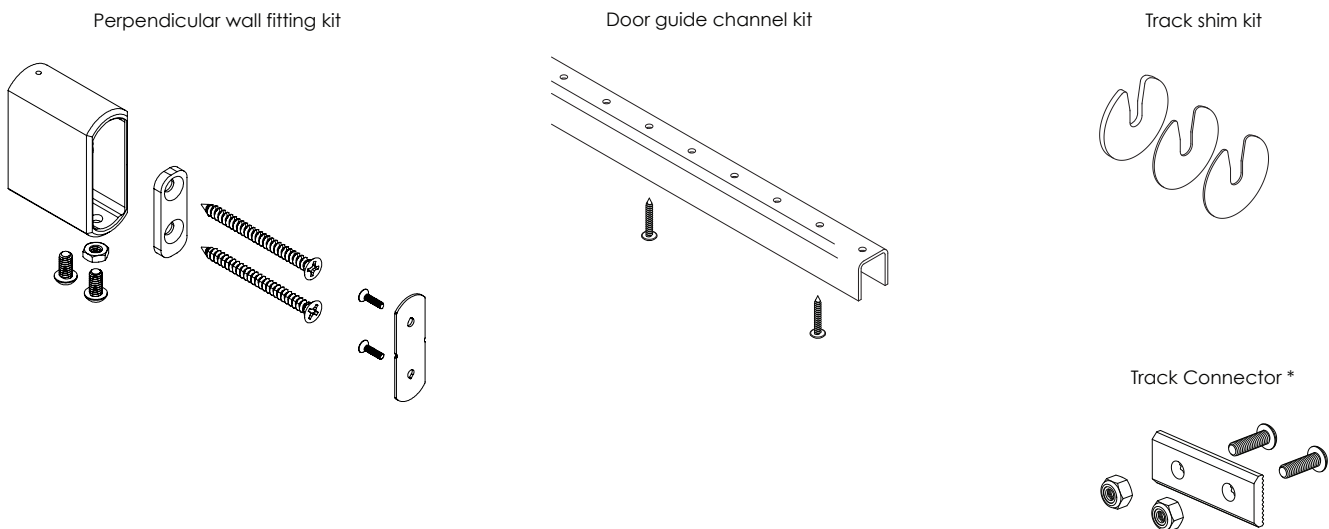

*Included with all orders where multiple tracks are spliced together. Located inside the track assembly.

3. REMOVE TRACK COVER

- ① Remove the track from the protective sleeve by gently prying the cover from the base with a slender plastic (non-marring) tool.
- ② If your order contains multiple tracks to be spliced together, remove the Track Connector located inside the track cavity.

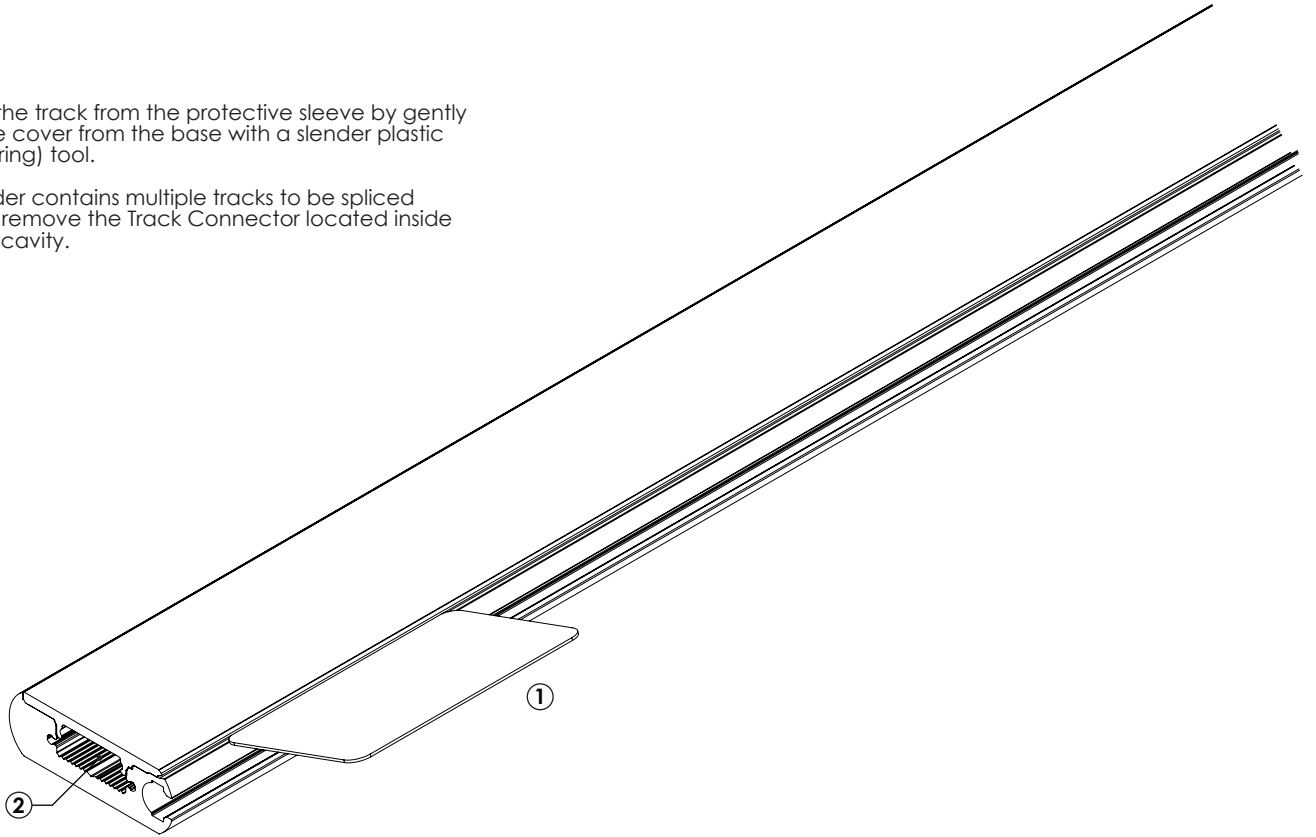

4. DETERMINE TRACK LOCATION ON WALL

- ① Determine the height of the track centerline:

$$\text{HEIGHT} = \text{DOOR PANEL HEIGHT} + 3''$$

This will result in approximately 3/8" of clearance between your door panel and the floor. Adjust if desired or necessary.

Add 3/4" to this dimension if you are using the optional door guide channel without door recess.

- ② Mark the track centerline on your wall.
- ③ Mark the desired location of the end point of your track above the door opening, ideally so that it aligns with the edge of your door panel in the desired closed position.
- ⚠ If track is being installed into wood studs, this location will be determined in the following steps.
- ④ If your track is being installed into wood studs, locate and mark door header height and stud locations.

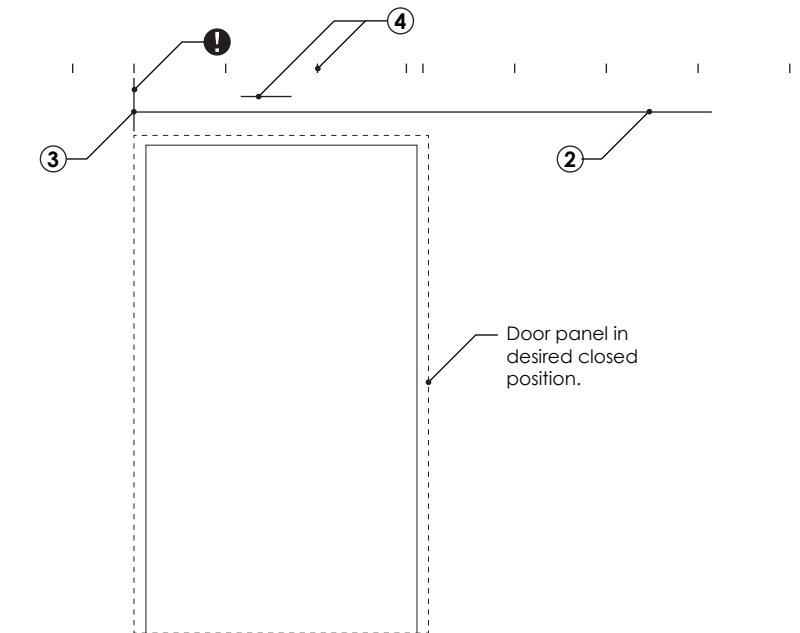

5. DETERMINE TRACK DRILL PATTERN

If your track base was ordered with mounting point holes drilled skip to step 9.

- ① If your track base was ordered undrilled, the installation wall condition determines the track mounting point drill pattern and weight capacity. Follow the applicable pattern rules below based on your wall condition.
- ❗ Installations with multiple adjoining tracks are required to be interlocked (step 10) in order to provide a continuous weight bearing surface. This is only compatible with the structural blocking drill pattern. See right table below and note that each track length has to follow the outlined pattern.
- ❗ Multiple tracks CANNOT be adjoined to provide a continuous weight bearing surface for installations where track mounting points are secured to wood studs. See left table below.

Stud Drill Pattern: (250 lb Max)**

Mounting point minimum: See table below.

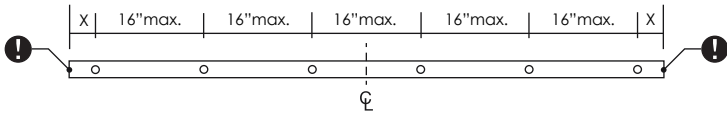

Panel weight	X*	Mounting points
Up to 100 lbs	5"	4 Minimum
101 - 200 lbs	4"	6 Minimum
201 - 250 lbs	3"	6 Minimum

* Maximum length of load-bearing track allowed beyond end mounting points. Non load-bearing track surface has no required minimum.

** Weight capacity is per track and may be further limited by trolley system.

Structural Blocking Drill Pattern: (400 lb Max)**

Mounting point minimum: 6

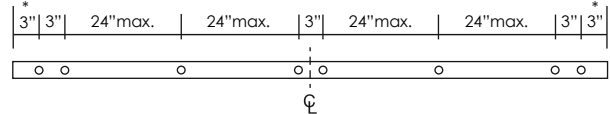

* Maximum length of load-bearing track allowed beyond end mounting points. Non load-bearing track surface has no required minimum.

** Weight capacity is per track and may be further limited by trolley system.

6. DETERMINE REQUIRED TRACK LENGTH

- ① Determine the desired open and closed positions of the door panel(s) considering door pulls and overlap region for the door guide. Calculate System Width (SW) for each door using the formula below:

$$SW = (\text{DOOR WIDTH} \times 2) - \text{TRAVEL OVERLAP}$$

- ❗ If your track is mounting to wood studs, Minimum Required track length will most likely exceed required System Width as determined by stud locations.
- ❗ For installations with multiple connected tracks, splice location requires blocking or for adjacent mounting point locations to attach to door header.

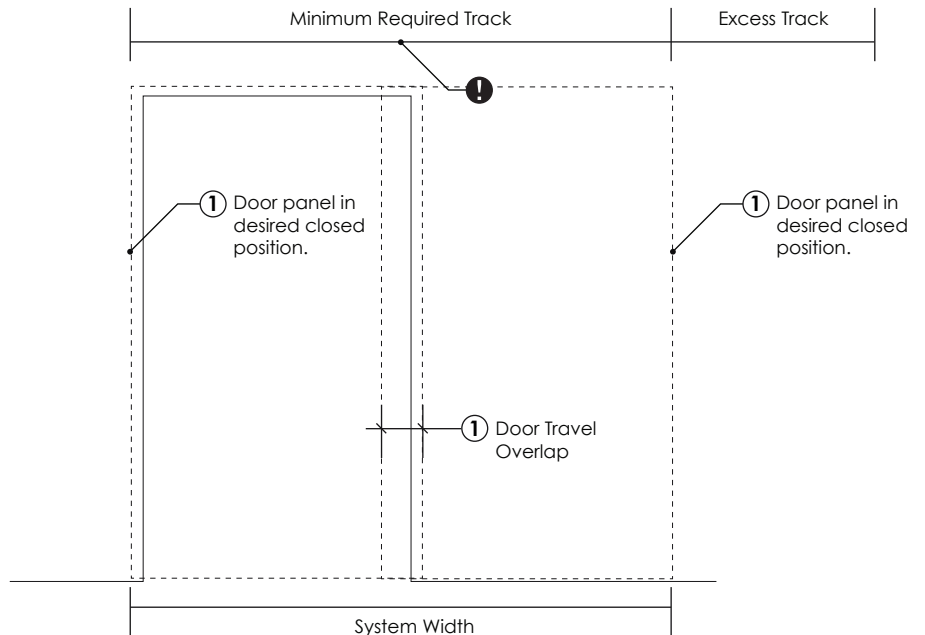

7. SYSTEM OPTION - CUT TRACK TO LENGTH

To optionally trim excess track length prepare track(s) for cutting:

- ① Mark track cut location as determined using the System Width formula in the previous step.
- ⚠ For tracks mounting to wood studs, ensure that site specific stud locations are considered.
- ② Gently press to slide track springs clear of cut location.
- ③ Carefully reattach track cover to track base.
- ④ Align profile ends and tightly wrap the assembly with painters tape to prevent shift during cutting.
- ⑤ Cut track assembly using the appropriate tool and blade.
- ⚠ Cut in horizontal orientation with cover facing up.
- ⑥ Carefully remove tape and track cover from base.

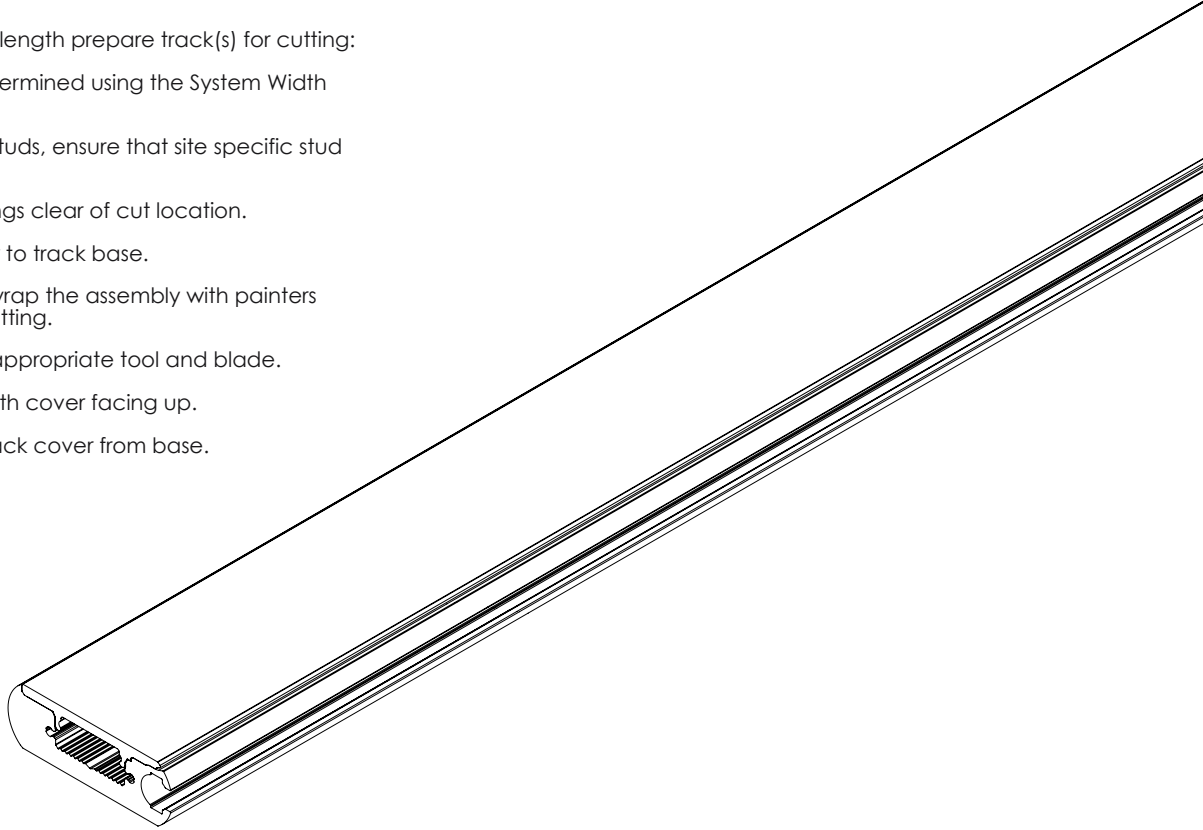

8. DRILL TRACK BASE

- ① With the appropriate lateral track wall position determined, apply the applicable Drill Pattern rules determined above.
- ⚠ For tracks mounting to wood studs, ensure that site specific stud locations are considered.
- ② Mark determined hole pattern and drill corresponding 9/16" holes along the centerline of the track base as shown.

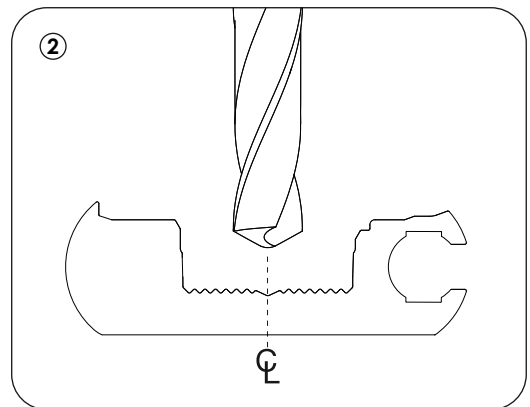
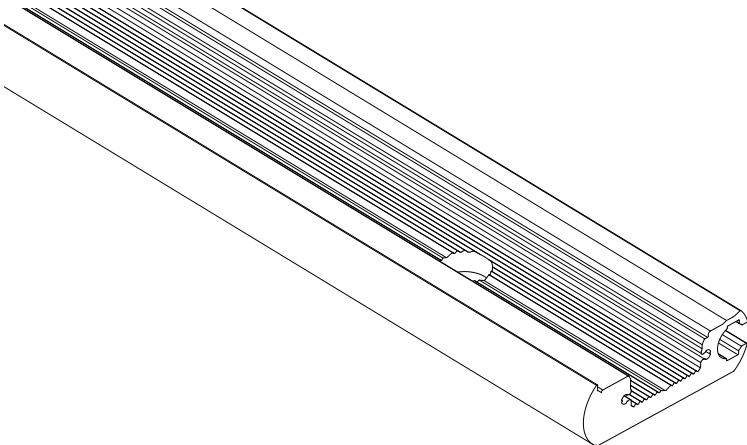

9. LOCATE TRACK ATTACHMENT POINTS ON WALL

- 1 Translate hole pattern in your drilled track base(s) to the previously scribed track centerline line.
- 1 Ensure that the determined lateral track wall position is considered.

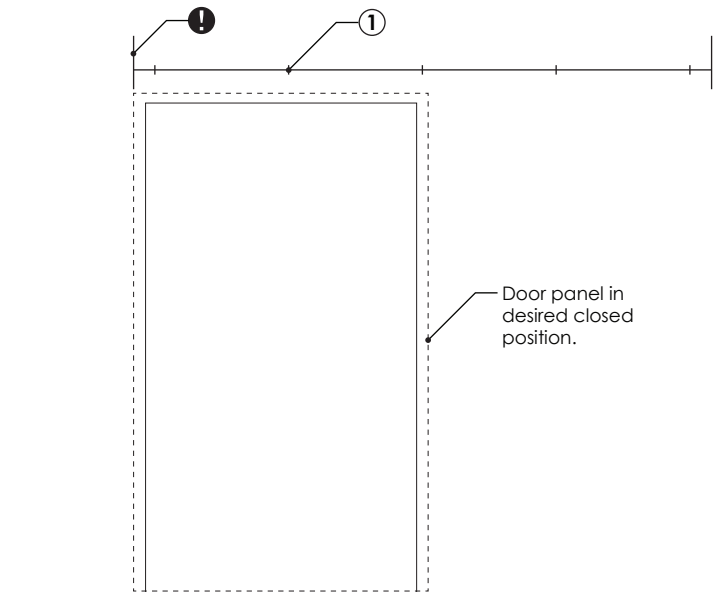

10. CONNECT TRACK BASES

Installations with multiple adjoining tracks are required to be interlocked in order to provide a continuous weight bearing surface. Skip to the next step for single-track installations.

- 1 Butt track bases end-to-end ensuring that the colored sticker dot indicators are matching and face track connection point(s) as shown.
- 2 Using the track connector washer plate centered over the seam as a template, mark track bases for drilling.
- 3 Drill 13/64" holes in each track base.
- 4 Connect track bases by installing the track connector as shown. Ensure that washer plate teeth align with teeth in the track base before tightening.
- 5 Using a torque wrench, tighten fasteners to 48 inch-lbs (4 ft-lbs).

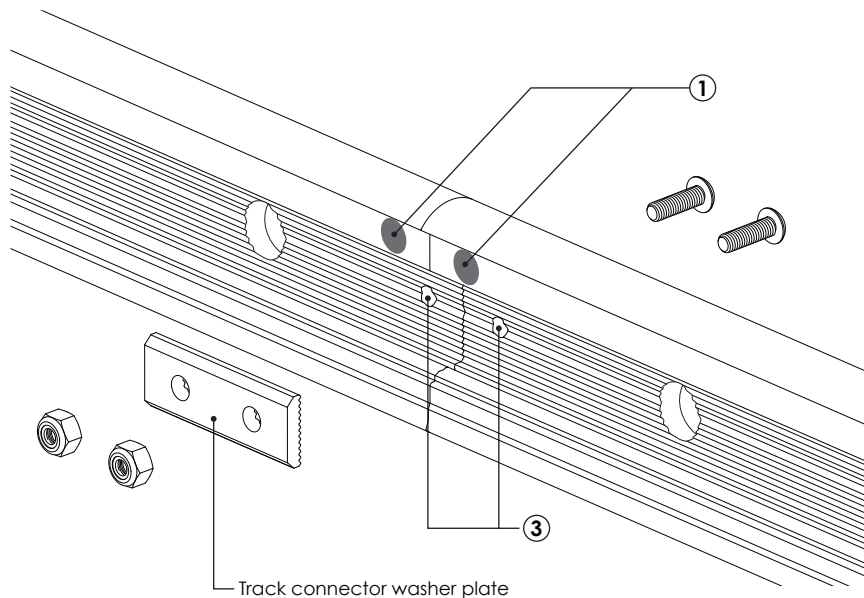
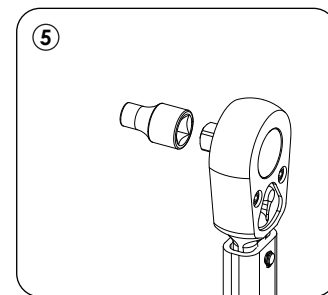

Track connectors are mandatory for all adjoining tracks in order to provide a continuous weight bearing surface.

II. INSTALL DRYWALL INSERTS

This step is for walls with a non-structural surface only. I.e., drywall, pin-up board or other materials that are structurally weaker than the substrate. Skip to the next step if your finished wall surface is structural.

- ① Use a 1-3/4" Forstner bit or similar to remove the drywall at each mounting point.
 - ② Place a drywall insert into each cavity.
- ❗ To perform their function, drywall inserts must be up against the structural material of your wall and flush with the finished surface. If needed, use the included steel shims as shown.

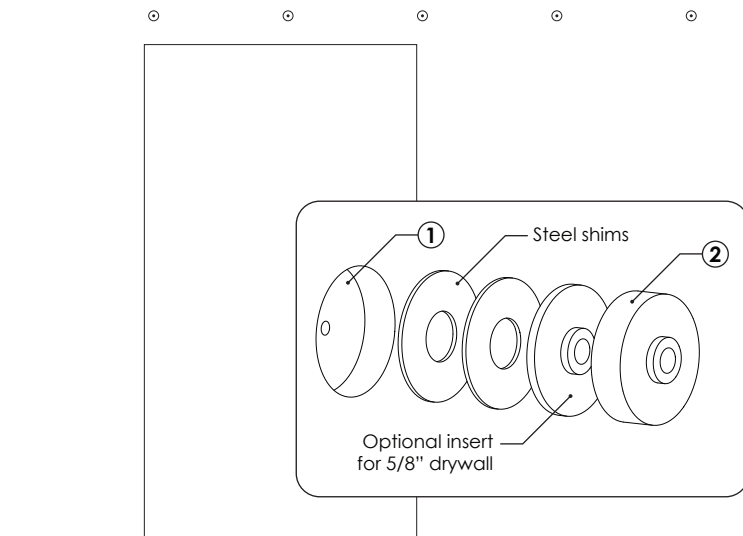

I2. PILOT DRILL STRUCTURAL WALL

- ① Drill a pilot hole for each mounting point for the provided mounting point fasteners.
- ❗ Ensure that each mounting point engages an appropriate amount of structural material.
- ❗ Krownlab hardware requires a structural wall to function properly and safely. Ensure that each mounting point engages an appropriate amount of structural material.
- ❗ Metal-studded framed walls must have 3" of solid blocking secured to studs or other framing members at each mounting point.
- ❗ Wood framed walls must have 3" of solid wood blocking secured to studs or other framing members. Mounting points can alternatively be secured to stud centers.

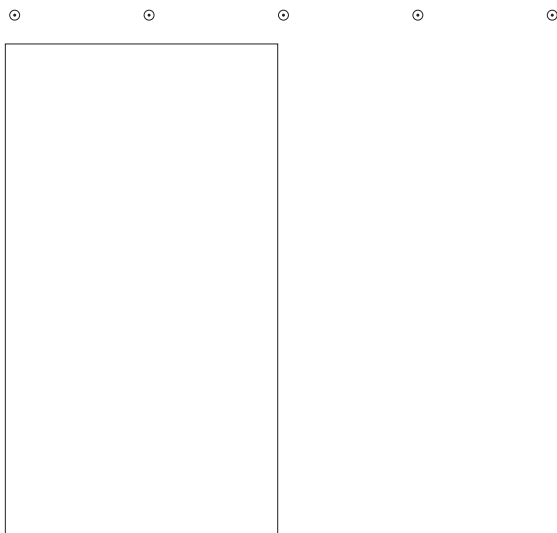

Structural requirements and suitability of other wall conditions to be determined by contractor or other qualified professional.

13. DETERMINE DOOR TO WALL CLEARANCE

- 1 Taking any protruding wall element* into consideration, calculate the desired door panel to wall surface clearance using the appropriate stack-up of the provided track mounting point stand-offs.

Track stand-offs included is dependant upon order configuration.

- 2 Door panel thickness is to be subtracted from drawing dimensions provided.

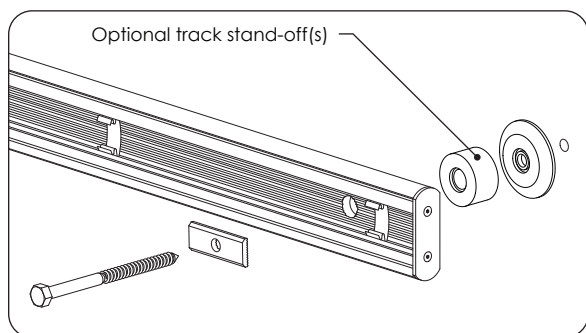

*Examples include: baseboard, door trim, electrical outlets and wall switches.

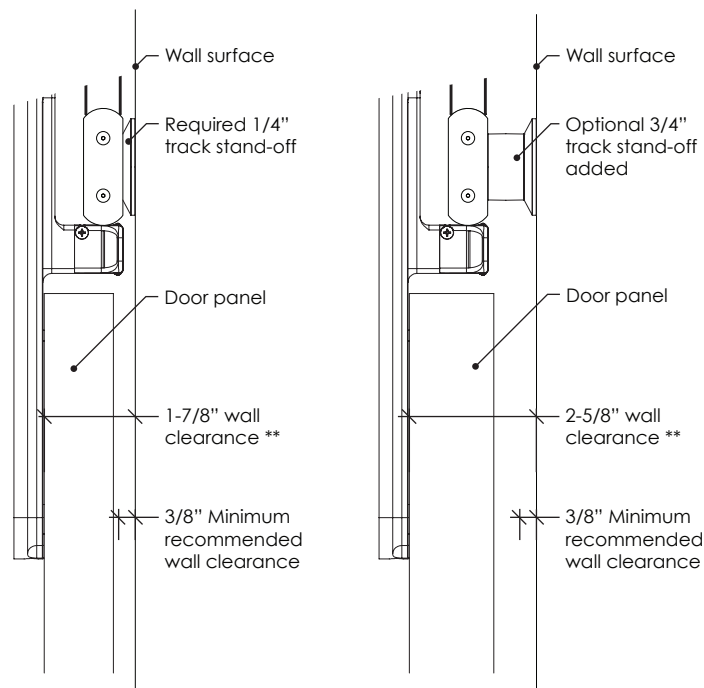

**Before subtracting door panel thickness.

14. INSTALL DOOR STOPS

- 1 Slide one door stop into each end of the track base. Do not yet tighten fasteners.
- 2 If installing Premium Door Stops, reference applicable installation instructions in parallel.

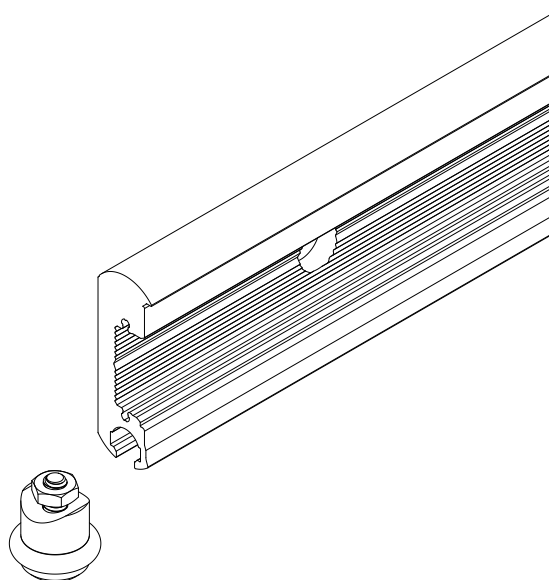

15. SYSTEM OPTION - INSTALL PERPENDICULAR WALL FITTING

If your order includes perpendicular wall fittings, reference applicable separate installation instructions in parallel to install the fitting.

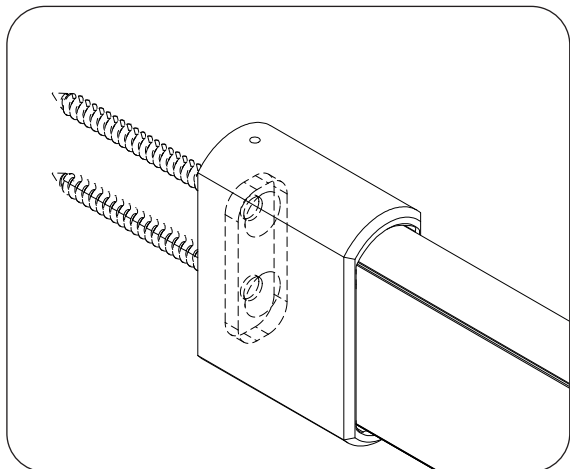

16. INSTALL END CAPS

- ⚠ End cap assembly may vary at each end of the track base.
- ① Select the scenario below that matches your track configuration:
 - No perpendicular wall fittings – follow the steps below for each track base end.
 - Perpendicular wall fitting on one end – follow the steps below for the opposite end.
 - Perpendicular wall fittings on both ends – the track was completed in the previous step. Proceed to the next step in these instructions.
- ② Using an Allen wrench gently secure the end cap to the track base. Do not over-tighten! Repeat on opposite end if applicable.

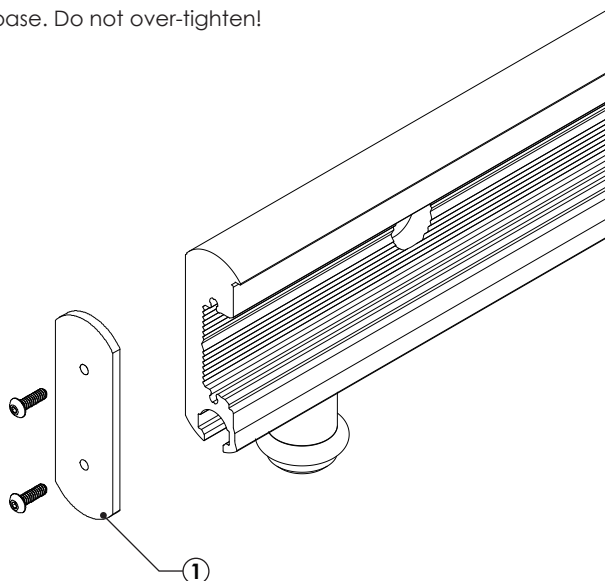

17. MOUNT TRACK BASE TO WALL

- ① If needed, gently press to slide track springs to be 1" away from holes to prevent clamping a spring under track washer plate. Evenly space springs along the length of track to ensure track cover is well-retained.
- ② With the door stops face down, loosely install one end of your track with the selected stack-up of track stand-offs and corresponding mounting fastener.
- ⚠ Total track stand-off greater than 1" requires the included 6" mounting fastener.
- ③ Repeat with the opposite end of the track.
- ⚠ Support the track assembly along its length if multiple tracks are linked together.
- ④ Loosely install the remaining mounting points.

⚠ Krownlab offers a range of mounting point fasteners for different wall conditions. Lag screws for walls with wood blocking are illustrated here. Contractor or other qualified professional to ensure suitability of provided fasteners for site-specific conditions.

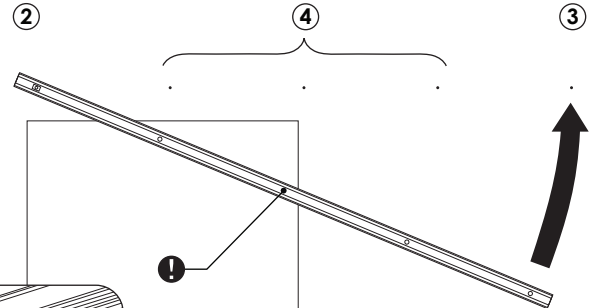
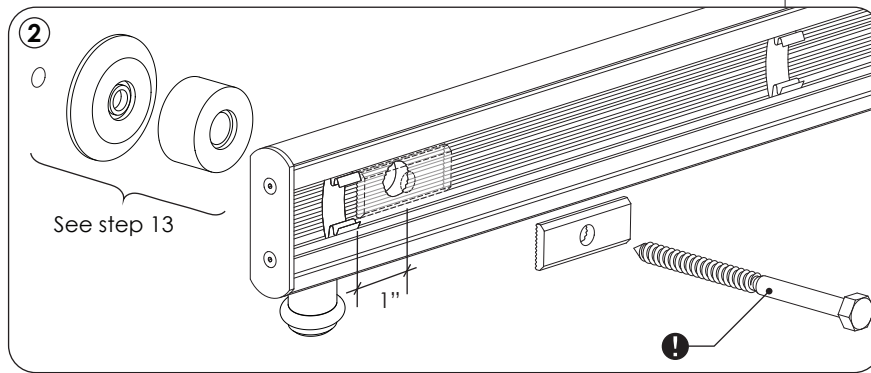

⚠ Krownlab's products are to be secured to structural elements able to support the weight of the door panel(s) and the dynamic forces of a sliding door system as determined by a qualified professional.

18. LEVEL AND ADJUST TRACK HEIGHT

- ① Snug, but don't yet tighten each track fastener starting at the center and moving toward the ends. For maximum adjustment, start by positioning the washer plate in the center (neutral) position.
- ⚠ Be sure to account for sloped or uneven floor when determining final desired track height.
- ② Using a level, adjust the position of the washer plate at each mounting point until track is level. If desired, adjust overall track height.
- ⚠ Ensure that washer teeth align with teeth in the track base before tightening fasteners.
- ③ Tighten all mounting points, doing final tightening by hand.
- ⚠ Do not over-tighten to deform track washer plates.

⚠ Installation on a vertical surface is required in order to ensure track base is installed plumb.

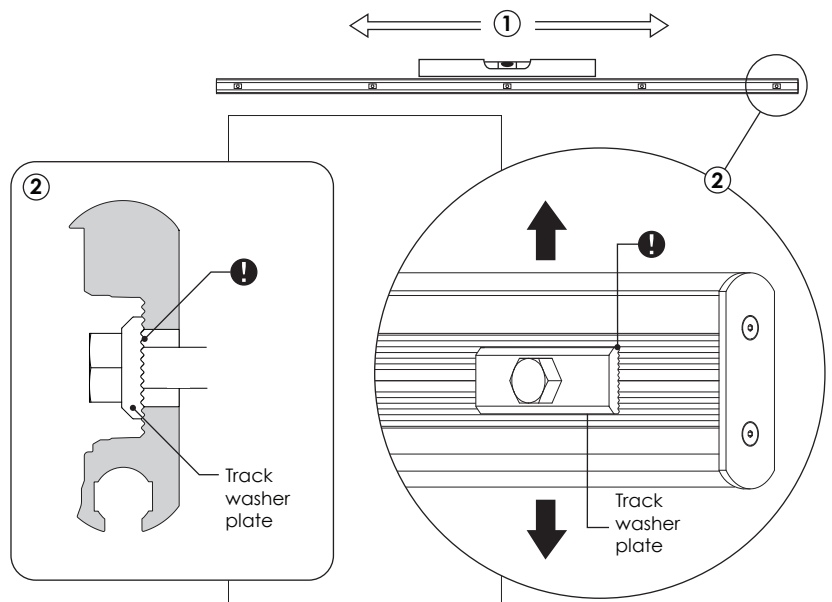
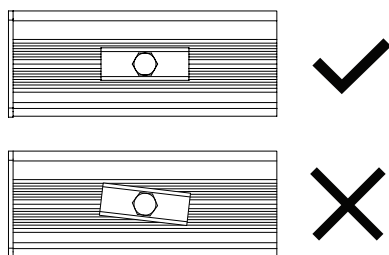

19. SYSTEM OPTION - INSTALL TRACK SHIMS

- ① Sight down the length of your track to determine if unevenness in the wall surface is causing your track to bow. Skip to the next step if track base is straight.
- ② If out of true, loosen select track attachment points as needed and insert shims from below as shown. Ensure that the opening of the shim faces up. Start with one of the thinner shims, adding and swapping shims as needed until the track is straight along entire length to within the thickness of one shim.
- ⚠ Never use more than one shim kit at any mounting point. Track shims may only be used at mounting points that pull the track out of true.

NOTE: Bowing in the track will negatively affect the system performance, causing increased friction and excessive wear. Krownlab's warranty does not cover wear caused by improper installation.

- ③ Retighten track fasteners to provided specifications.

Optional track stand-off(s)

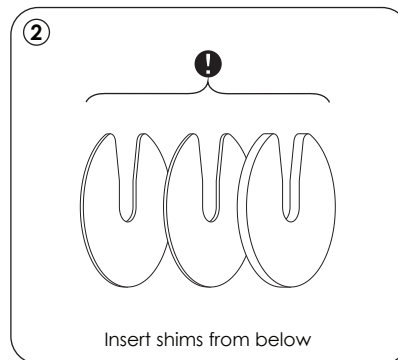
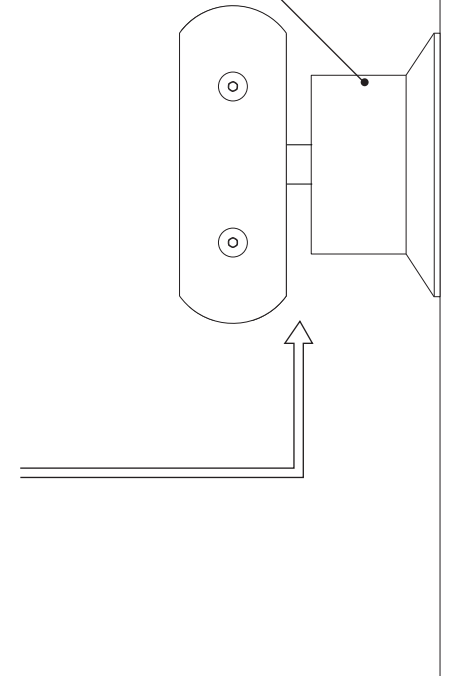

Do not use shims for the purpose to extend the track standoff distance.

20. SECURE TRACK COVER

- ① Confirm that track base is level, straight, and that all mounting points have been securely fastened.
- ② Inspect each track spring to ensure no interference with the mounting hardware and that they are evenly spaced along the length of the track base.
- ⚠ For installations with multiple connected tracks, ensure that the colored sticker dot indicators on inside of track cover are matching track base color and face track connection point(s).
- ⚠ Ensure that the arrow on the inside of the track cover is facing up.
- ③ Carefully reattach track cover(s) to track base(s) confirming fully seated and securely attached along the entire length. Adjust track spring locations if needed.

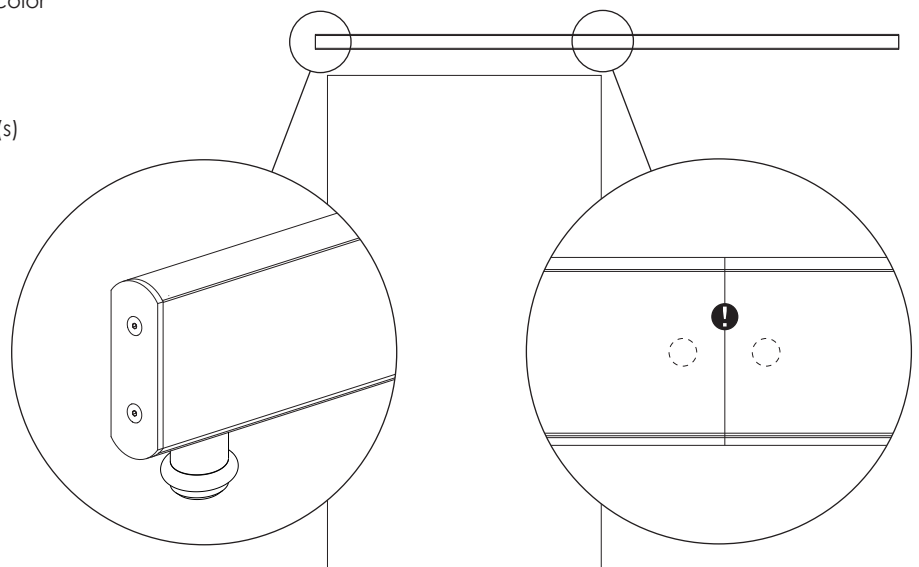
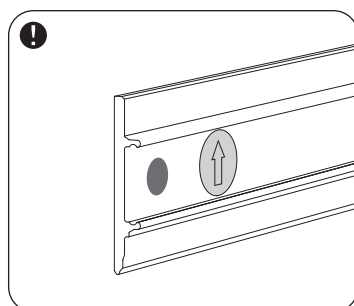

21. PREPARE DOOR PANEL FOR DOOR GUIDE

Refer to the separate installation instructions for the door guide that is included with your order*. Once door is appropriately prepared, return to this document for next steps.

*Included door guide may vary from examples shown below.

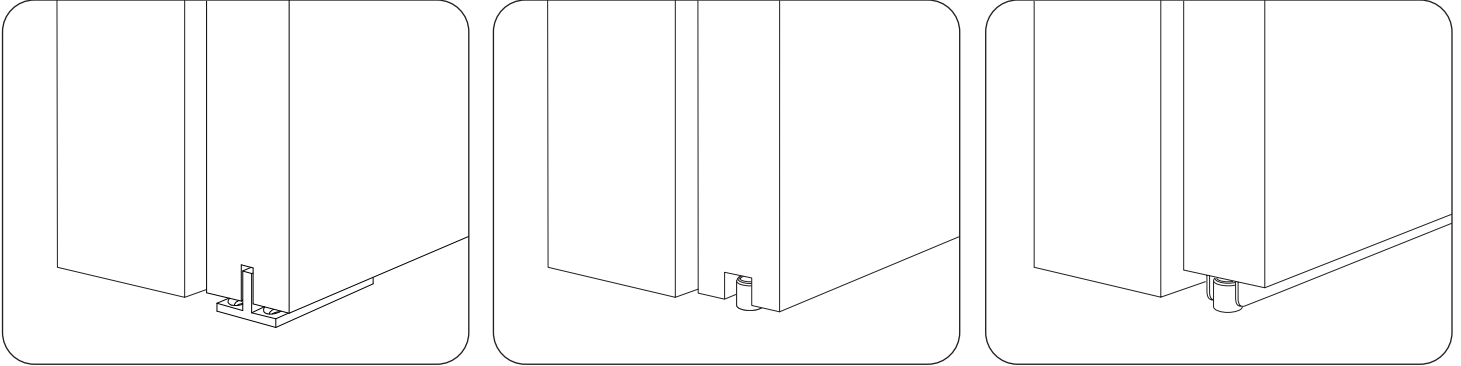

Installation of a door guide is required and must for safety be engaged along the full length of door travel.

22. PREPARE DOOR PANEL FOR TROLLEYS

- ① Drill door panel(s) to accept the trolleys as shown.
- ② Also prepare for - but do not yet install - door pulls and other door hardware part of the installation.



Trolleys are to be secured to structural material able to support the weight of the door panel and the dynamic forces of a sliding door system.

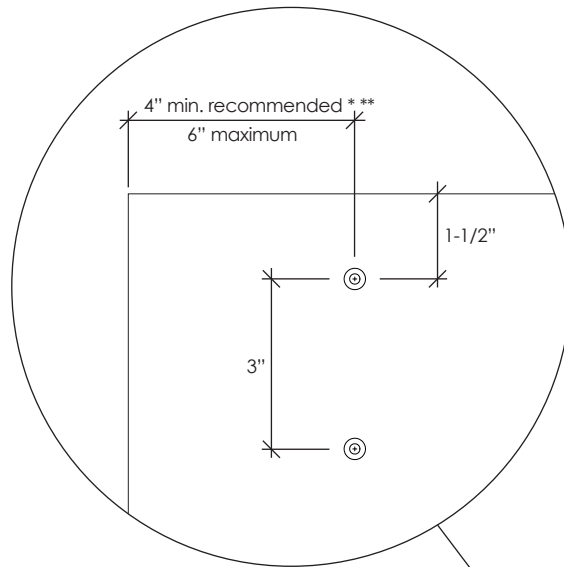
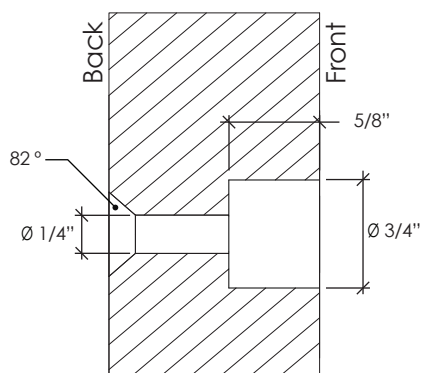

* Facilitates easier door guide installation.

** Min. required for Premium Door Stops.

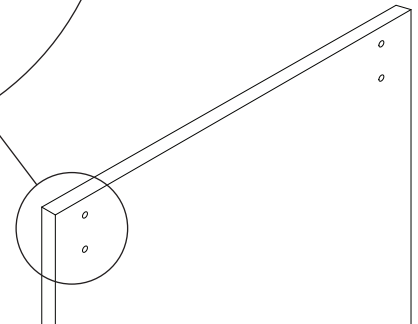

23. ATTACH TROLLEYS TO DOOR PANEL

- ① Install the trolleys onto the door panel(s) using the correct length fastener as shown in the table below.
- ② Ensure that trolleys sit vertical on the door panel.
- ③ Using a torque wrench, tighten fasteners to between 36 and 108 inch-lbs (3-9 ft-lbs), depending on door materials. A denser door material (ex. Metal) will need more torque than a lightweight material (ex. Wood).
- ④ Carefully hang your door panel(s).
- ⚠ Do not yet install your door pulls or other door hardware.

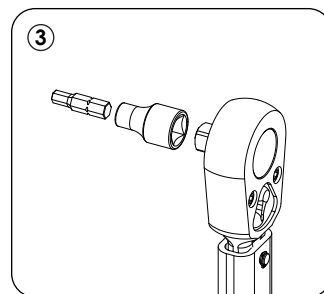

Panel thickness	Screw length
1-1/4" to 1-3/8"	1-1/4"
1-1/2" to 1-3/4"	1-1/2"
1-7/8" to 2-1/4"	2"
2-3/8" to 2-1/2"	2-1/2"

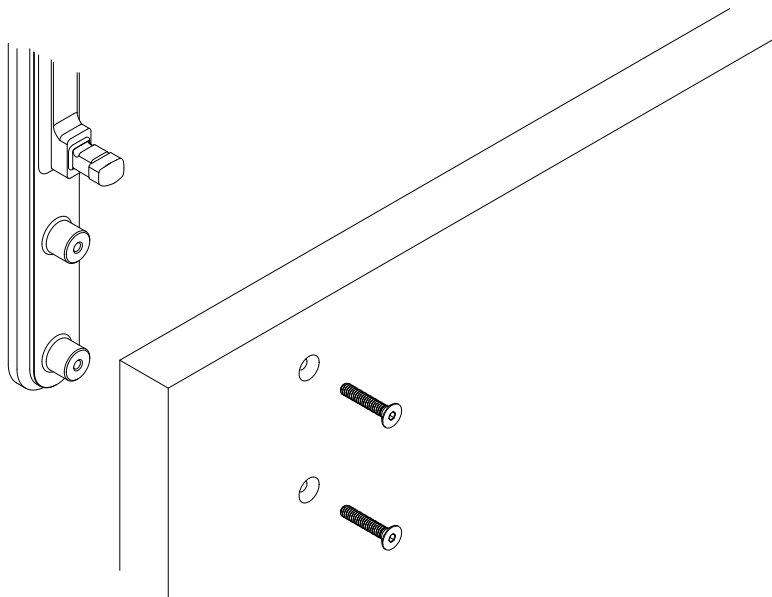

24. ADJUST DOOR PANEL HEIGHT

- ① If required, door panel height can be adjusted up or down by raising or lowering the track base as outlined in step 18.

25. INSTALL SAFETY STOPS

If installing Premium Door Stops, reference those installation instructions in parallel.

- ① Remove protective cap from trolley post.
- ② Place one safety stop on the trolley post.
- ⚠ Ensure the safety stop is fully seated and properly aligned so that half of the post is completely covered by the safety stop.
- ③ Slide the second safety stop over the other side of the post.
- ⚠ Ensure that both safety stops are aligned and fully seated.
- ④ Thread provided screws into both sides of the safety stops using a #2 Phillips Screw Driver and lightly tighten.
- ⑤ Repeat above steps for second trolley.

NOTE: Keep the protective caps and reuse when removing and rehangng door panel to prevent damage to track.

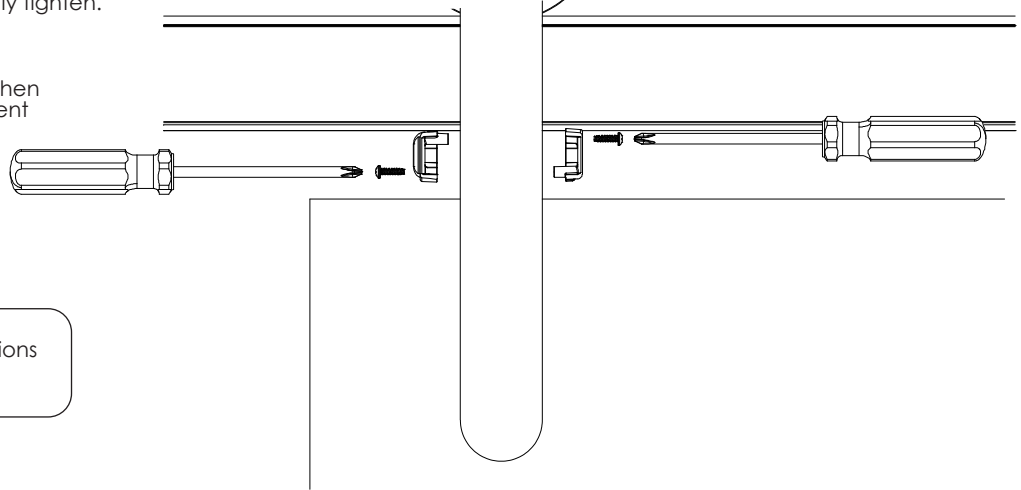
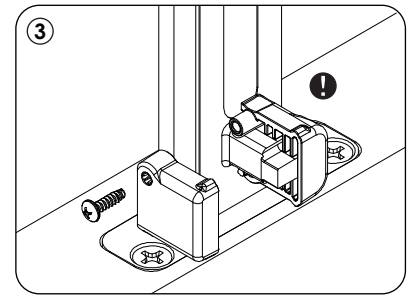

Not fully following the above instructions can cause a hazardous condition.

26. INSTALL DOOR GUIDE

Refer to the separate installation instructions for the door guide that is included with your order*. Once installed, continue to next step.

*Included door guide may vary from examples shown below.

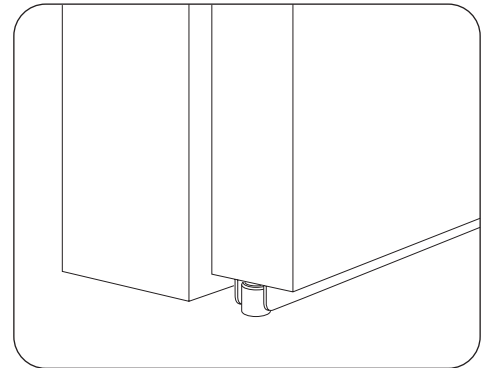
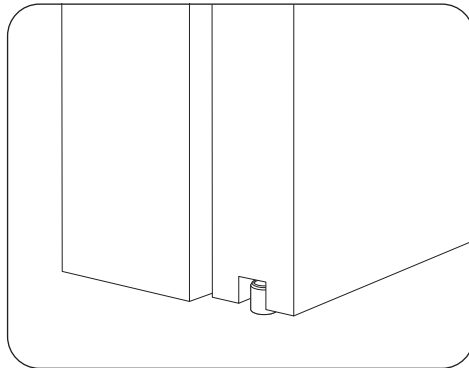
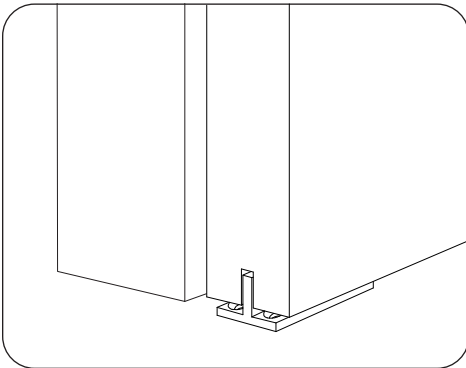

Installation of a door guide is required and must for safety be engaged along the full length of door travel.

27. INSTALL DOOR PULLS

- 1 If applicable, install door pulls following applicable installation instructions.

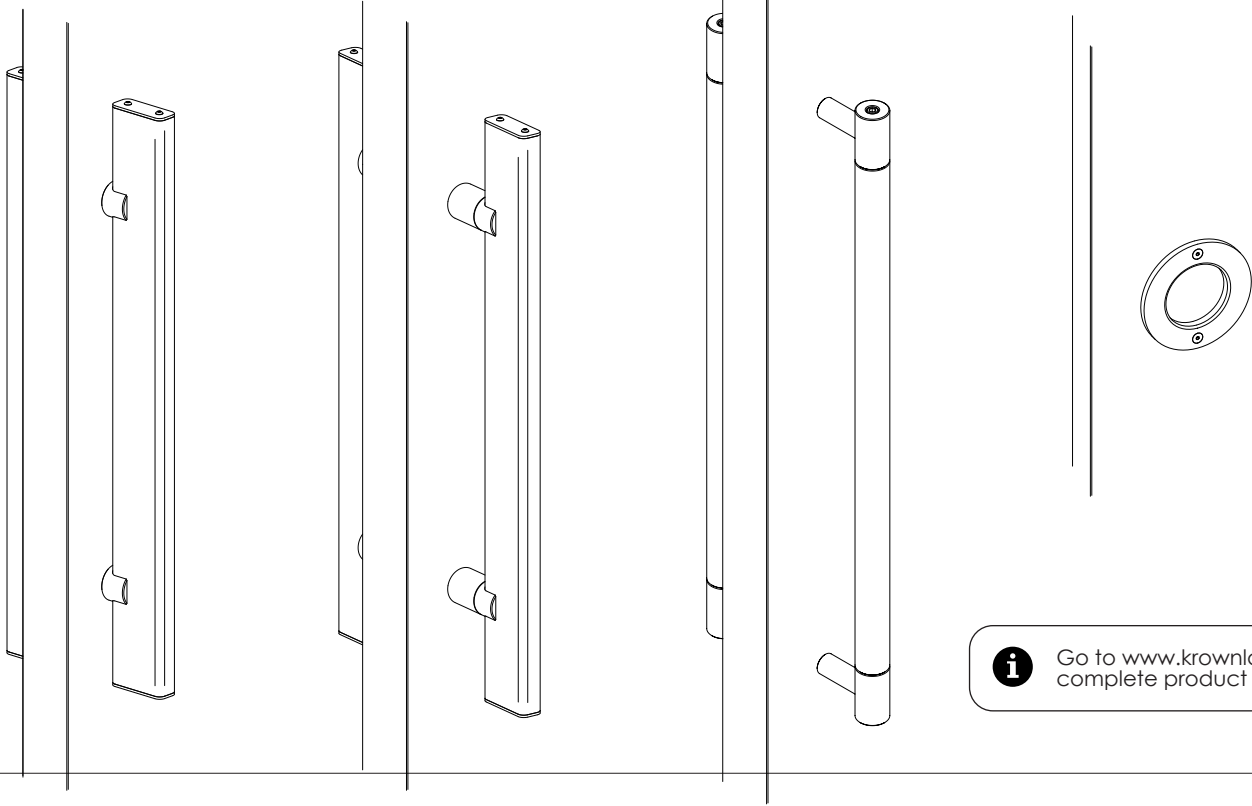

i Go to www.krownlab.com for our complete product range.

28. SET DOOR TRAVEL

If installing Premium Door Stops, reference those installation instructions in parallel.

- 1 With the door in the desired closed position, slide the door stop so that it touches the safety stop of the nearby trolley.
- 2 Repeat with the door in the open position, sliding the door stop so that it touches the safety stop of the nearby trolley.
- 3 Verify that the door guide is properly engaged in both the fully open and fully closed positions.
- 3 Tighten all door stop fasteners in place by hand.
- 4 Confirm locations haven't shifted while tightening. Adjust if needed.
- 5 Using a torque wrench, tighten fasteners to 110 inch-lbs (9.5 ft-lbs).

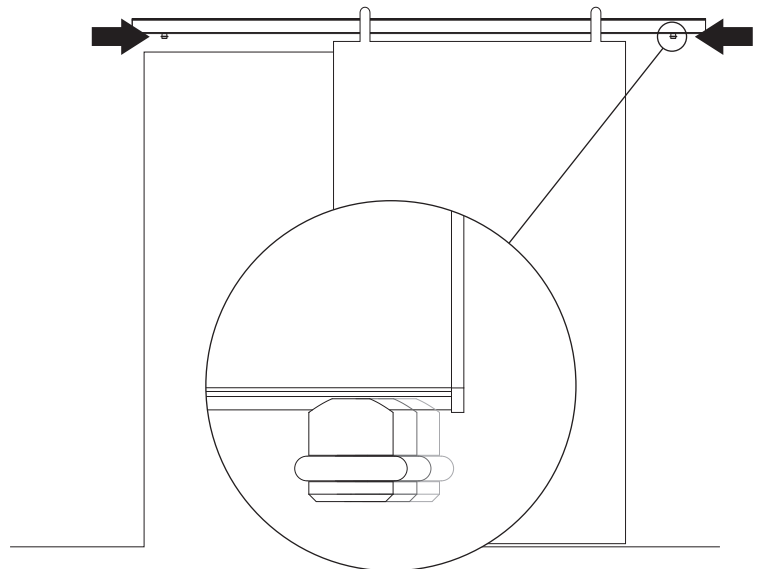
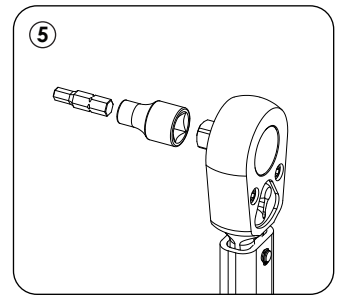

29. CARE AND MAINTENANCE

- ❗ Krownlab products require routine care and maintenance. Read and understand these requirements in our Product Care & Maintenance guide.
- ① Thoroughly clean product and remove all debris and fingerprints immediately after installation as described in our Product Care & Maintenance guide.
- ② Enjoy your new exceptional Krownlab Sliding Door System.

Visual product representations herein may differ from the actual products. Components and details are subject to improvement changes.

© 2023 Krownlab. All Rights Reserved. Krownlab and the Krownlab logo is registered Trademark of Krown Lab, Inc.
