

DOCUMENT: PRODUCT SPECIFICATIONS	DOOR APPLICATION: SINGLE, BI-PARTING, BYPASSING	DRAWING SCALE: 3/4" = 1'-0" (1:16)	KROWNLAB 2351 NW York St. Portland, OR 97210 +1 503 292 6998 www.krownlab.com support@krownlab.com
SYSTEM: LOKI	PANEL THICKNESS: 1-3/8" MINIMUM	UNITS: INCHES	
MOUNTING STYLE: TOP MOUNT	MAXIMUM WEIGHT: UP TO 200LBS (CONTACT US FOR HEAVIER PANELS)	DATE: 3/30/2018	

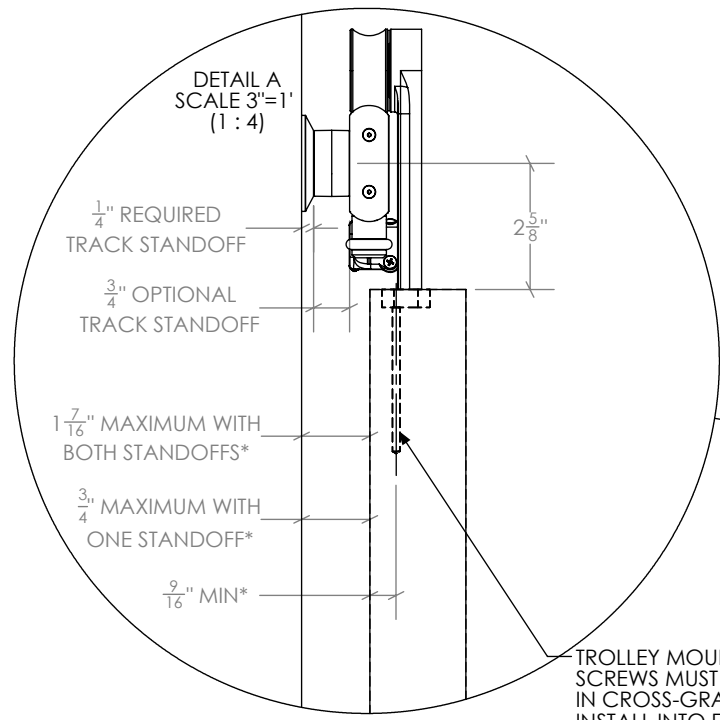

TROLLEY MOUNTING SCREWS MUST BE INSTALLED IN CROSS-GRAIN. NEVER INSTALL INTO END-GRAIN.

\* = THESE LIMITS VARY WITH WOOD SPECIES.

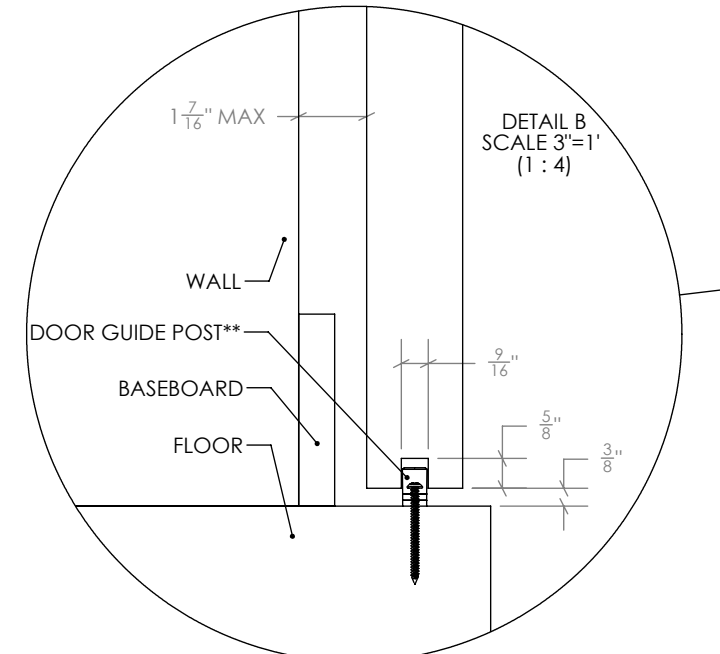

\*\* = DOOR GUIDE MAY DIFFER

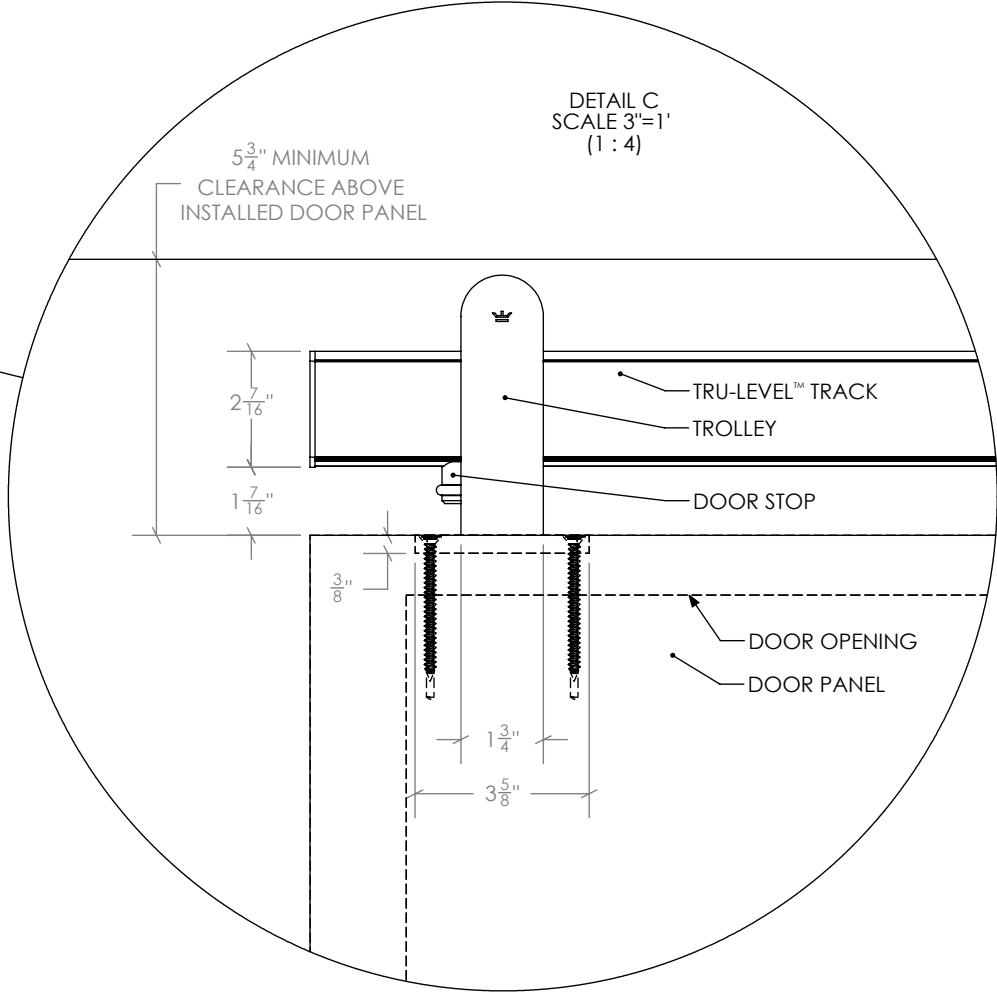
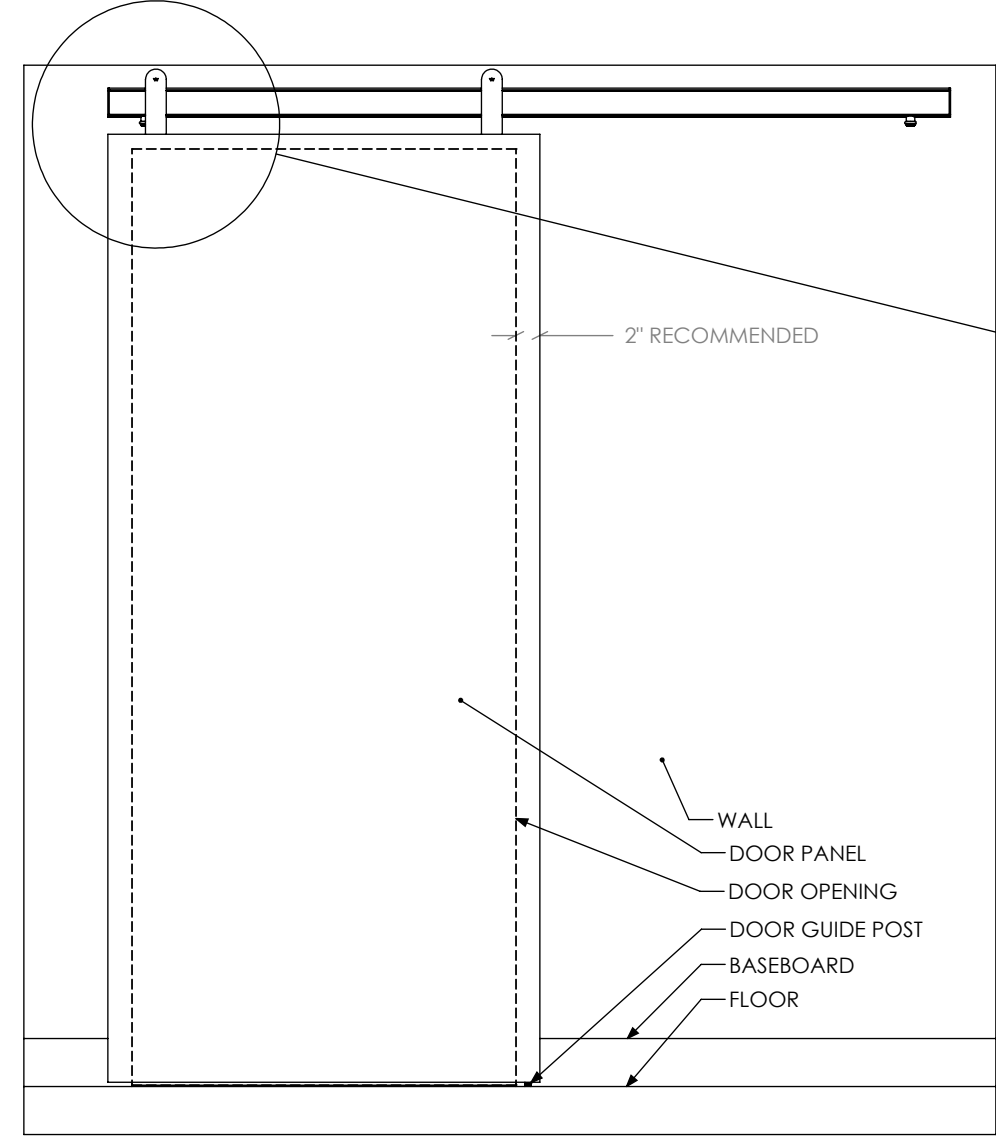

DOCUMENT:	PRODUCT SPECIFICATIONS	DOOR APPLICATION:	SINGLE & BI-PARTING	DRAWING SCALE:	3/4" = 1'-0" (1:16)	KROWNLAB 2351 NW York St. Portland, OR 97210 +1 503 292 6998 www.krownlab.com support@krownlab.com
SYSTEM:	LOKI	PANEL THICKNESS:	3/4" TO 2-1/2"* (CHOOSE TOP MOUNT FOR THICKER PANELS)	UNITS:	INCHES	
MOUNTING STYLE:	FACE MOUNT	MAXIMUM WEIGHT:	UP TO 200LBS (CONTACT US FOR HEAVIER PANELS)	DATE:	3/30/2018	



\* = 2-1/2" PANEL WILL HAVE 1/4" WALL CLEARANCE.

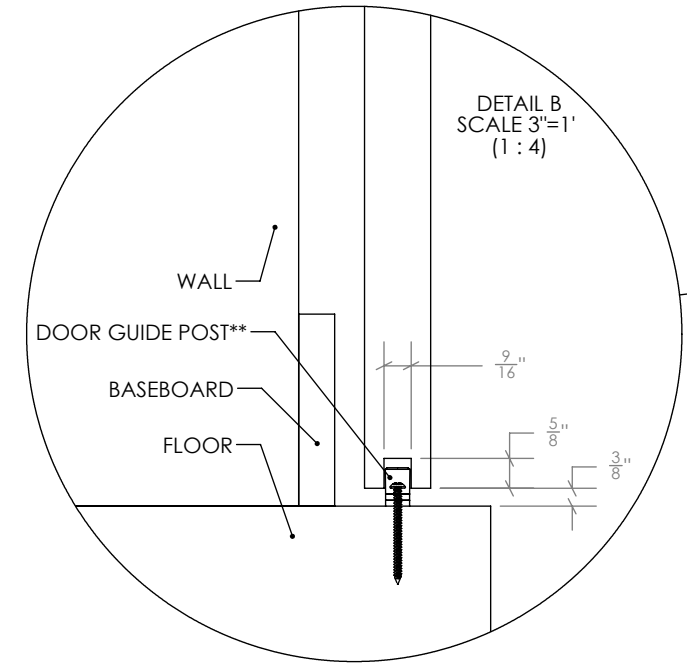
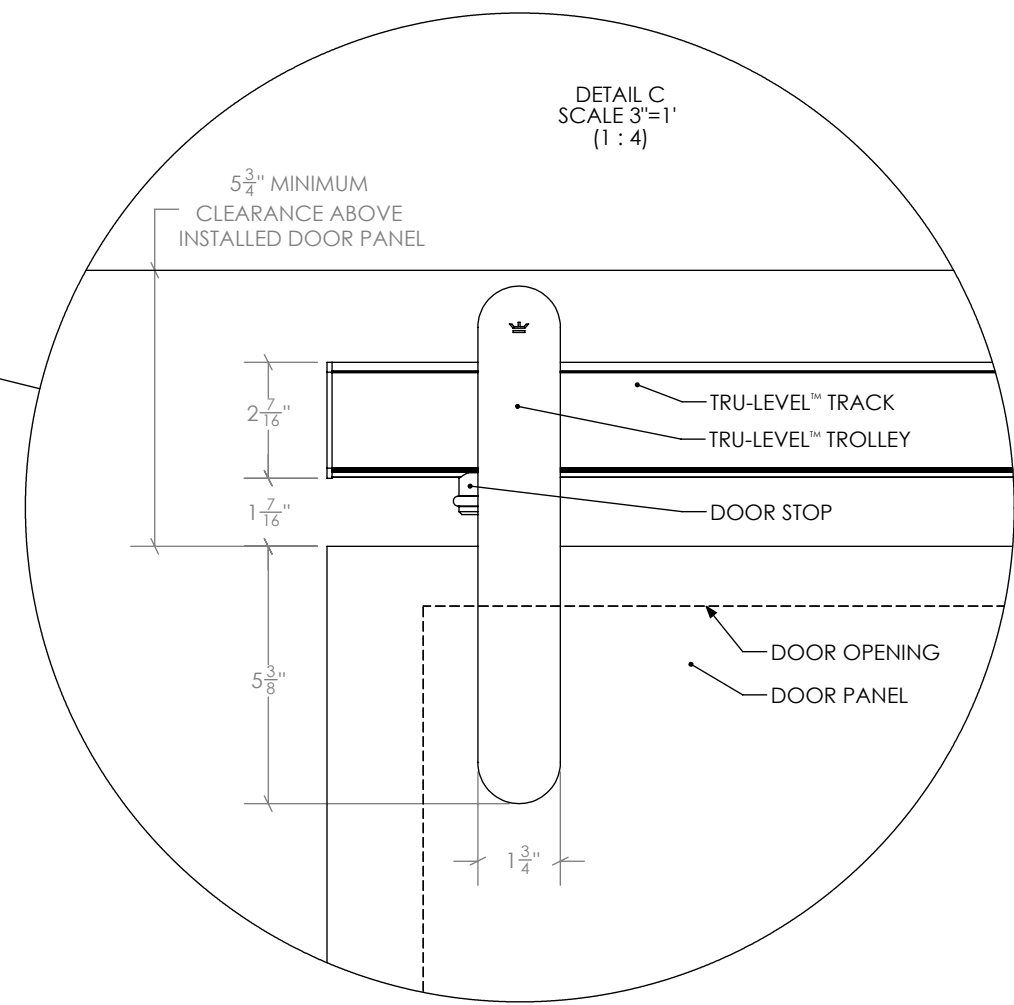
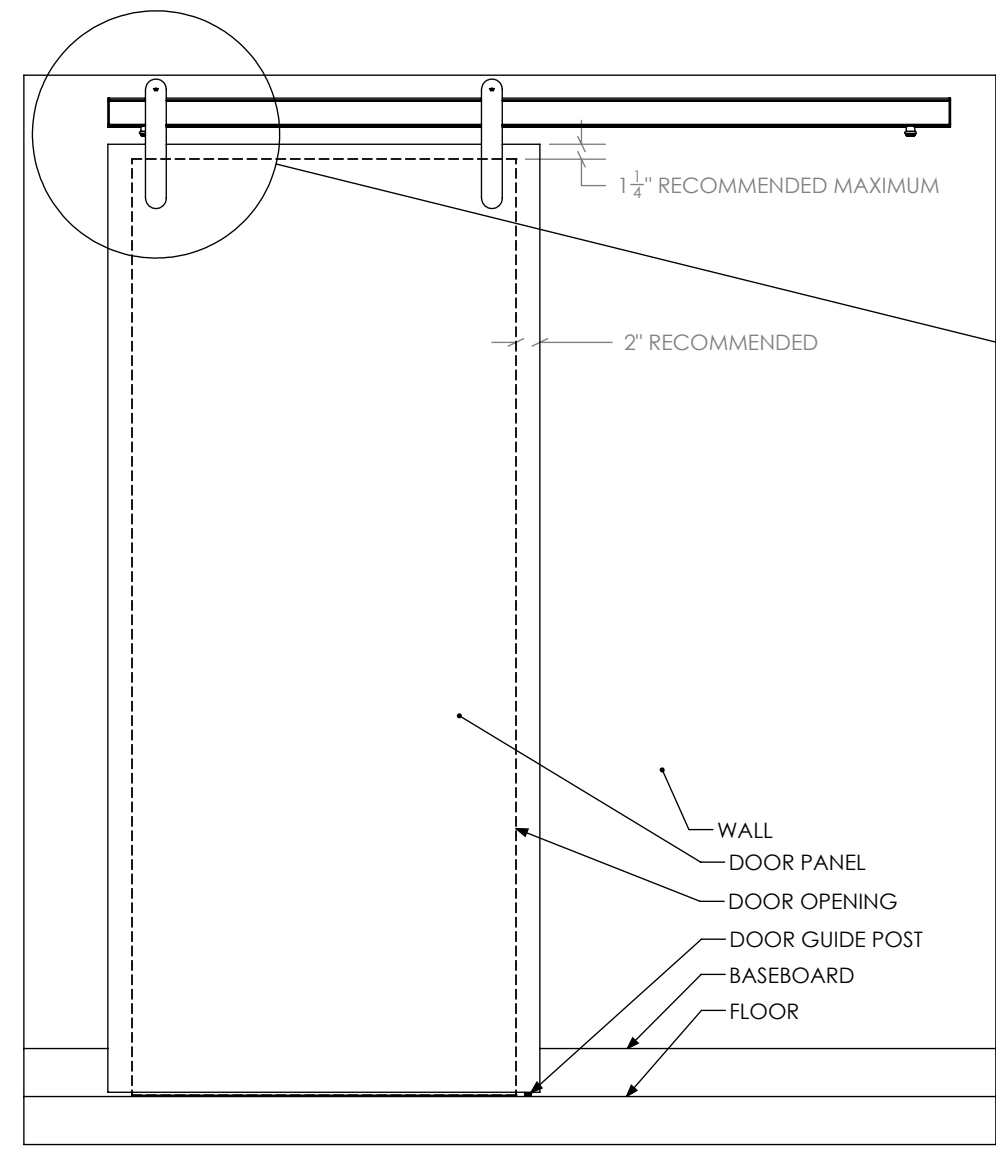
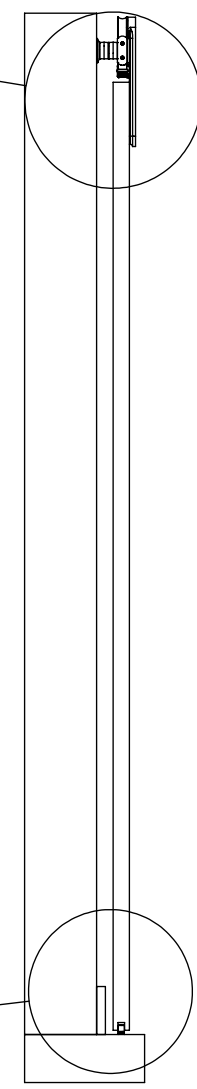
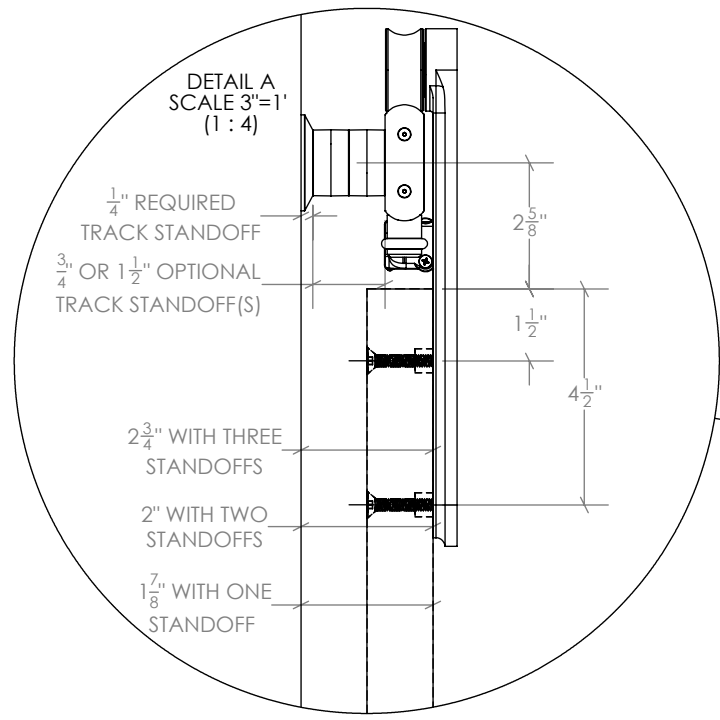

\*\* = DOOR GUIDE MAY DIFFER

DOCUMENT: PRODUCT SPECIFICATIONS	DOOR APPLICATION: SINGLE, BI-PARTING, BYPASSING	DRAWING SCALE: 3/4" = 1'-0" (1:16)	KROWNLAB 2351 NW York St. Portland, OR 97210 +1 503 292 6998 www.krownlab.com support@krownlab.com
SYSTEM: LOKI	PANEL THICKNESS: 3/8" TO 1/2" (CONTACT US FOR PANELS OUTSIDE OF THIS RANGE)	UNITS: INCHES	
MOUNTING STYLE: GLASS MOUNT	MAXIMUM WEIGHT: UP TO 200LBS (CONTACT US FOR HEAVIER PANELS)	DATE: 3/30/2018	

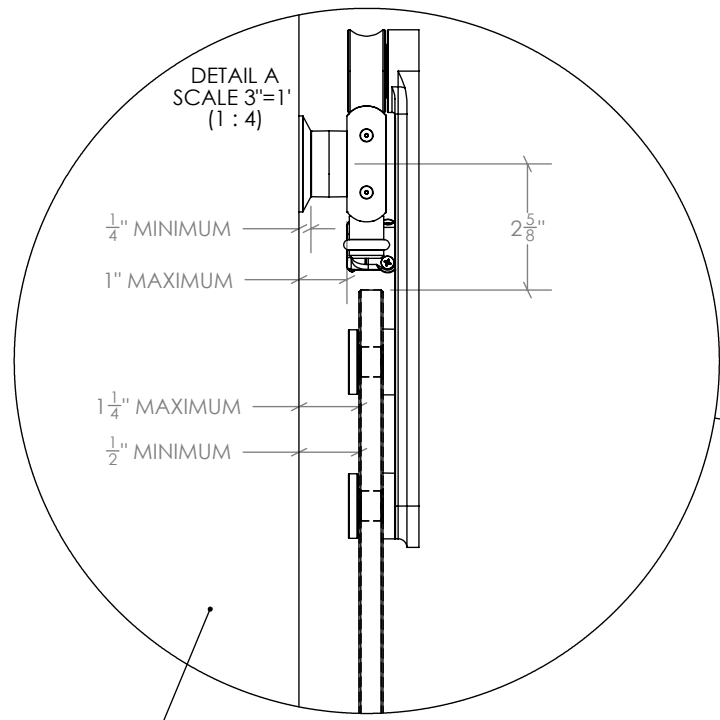

GENERIC WALL SHOWN. TRU-LEVEL TRACK DRAWINGS IN FOLLOWING PAGES WILL COVER FRAMED AND GLASS WALL TYPES.

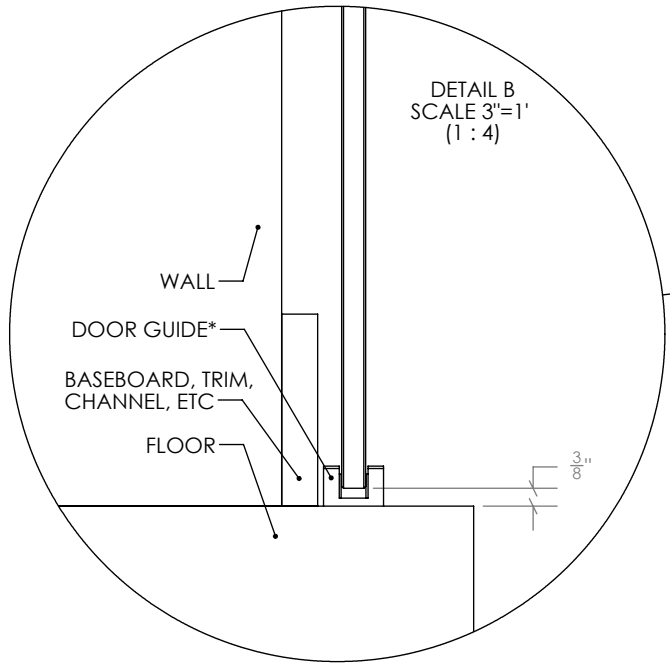
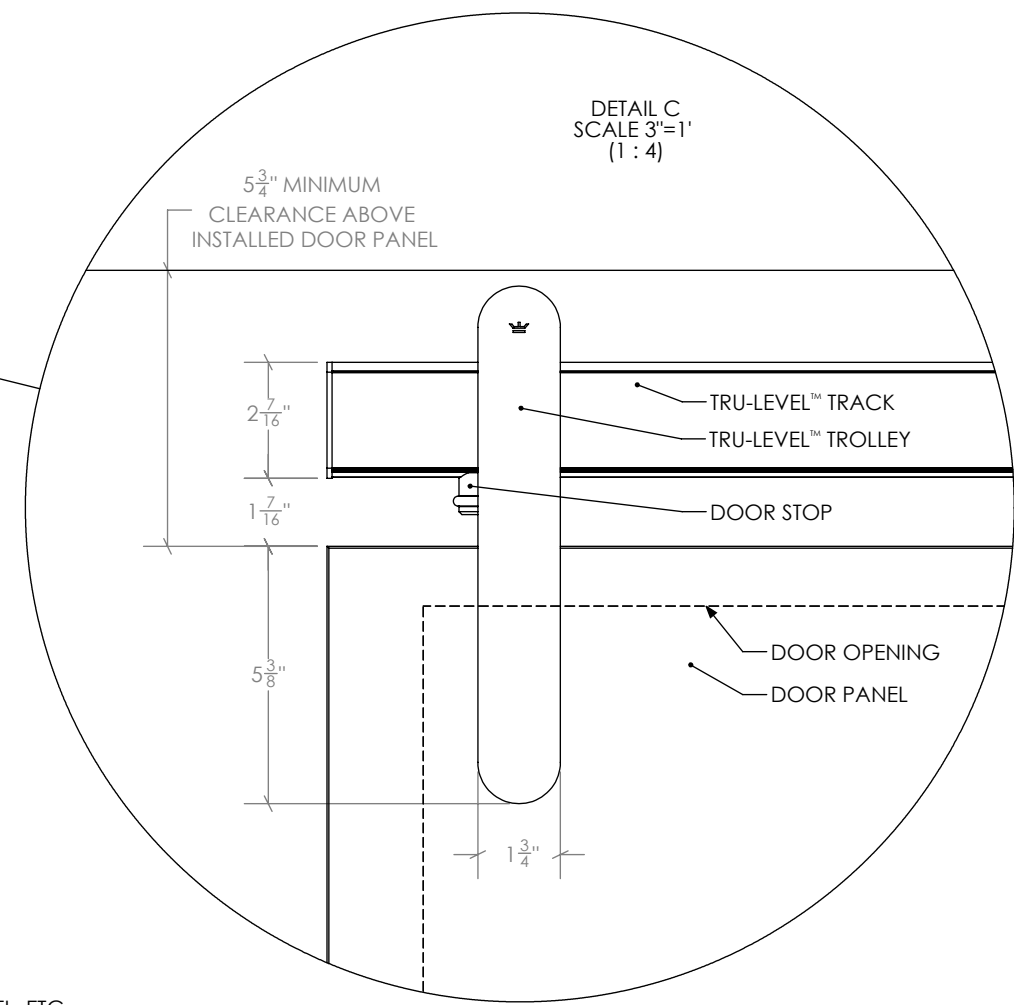
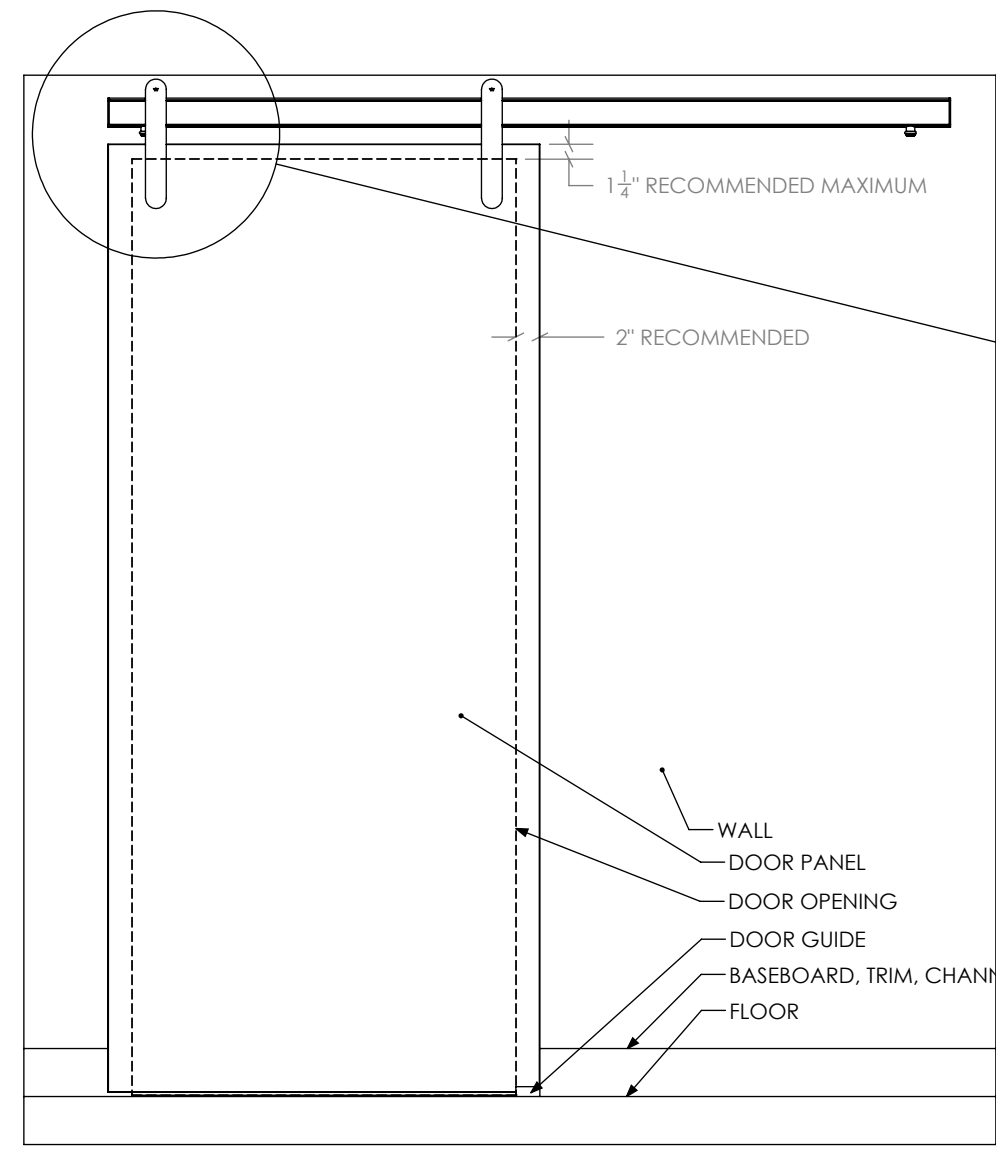
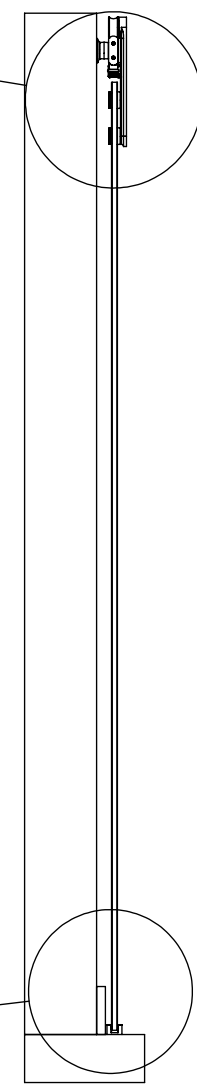

\* = DOOR GUIDE MAY DIFFER

DOCUMENT:	PRODUCT SPECIFICATIONS	DOOR APPLICATION:	SINGLE, BI-PARTING, BYPASSING	DRAWING SCALE:	4" = 1'-0" (1:3)	KROWNLAB 2351 NW York St. Portland, OR 97210 +1 503 292 6998 www.krownlab.com support@krownlab.com
SYSTEM:	LOKI	PANEL THICKNESS:	1-3/8" MINIMUM	UNITS:	INCHES	
MOUNTING STYLE:	TOP MOUNT	MAXIMUM WEIGHT:	UP TO 200LBS (CONTACT US FOR HEAVIER PANELS)	DATE:	3/30/2018	



WHAT'S INCLUDED:  
 2 x - #A330 - LOKI TOP MOUNT TROLLEY KIT  
 1 x - #A020 - DOOR GUIDE POST KIT (DOOR GUIDE MAY DIFFER - MULTIPLE OPTIONS EXIST)  
 1 x - #Txxxx - TRU-LEVEL™ TRACK SYSTEM WITH ALL MOUNTING HARDWARE (SEE SEPARATE PAGE)

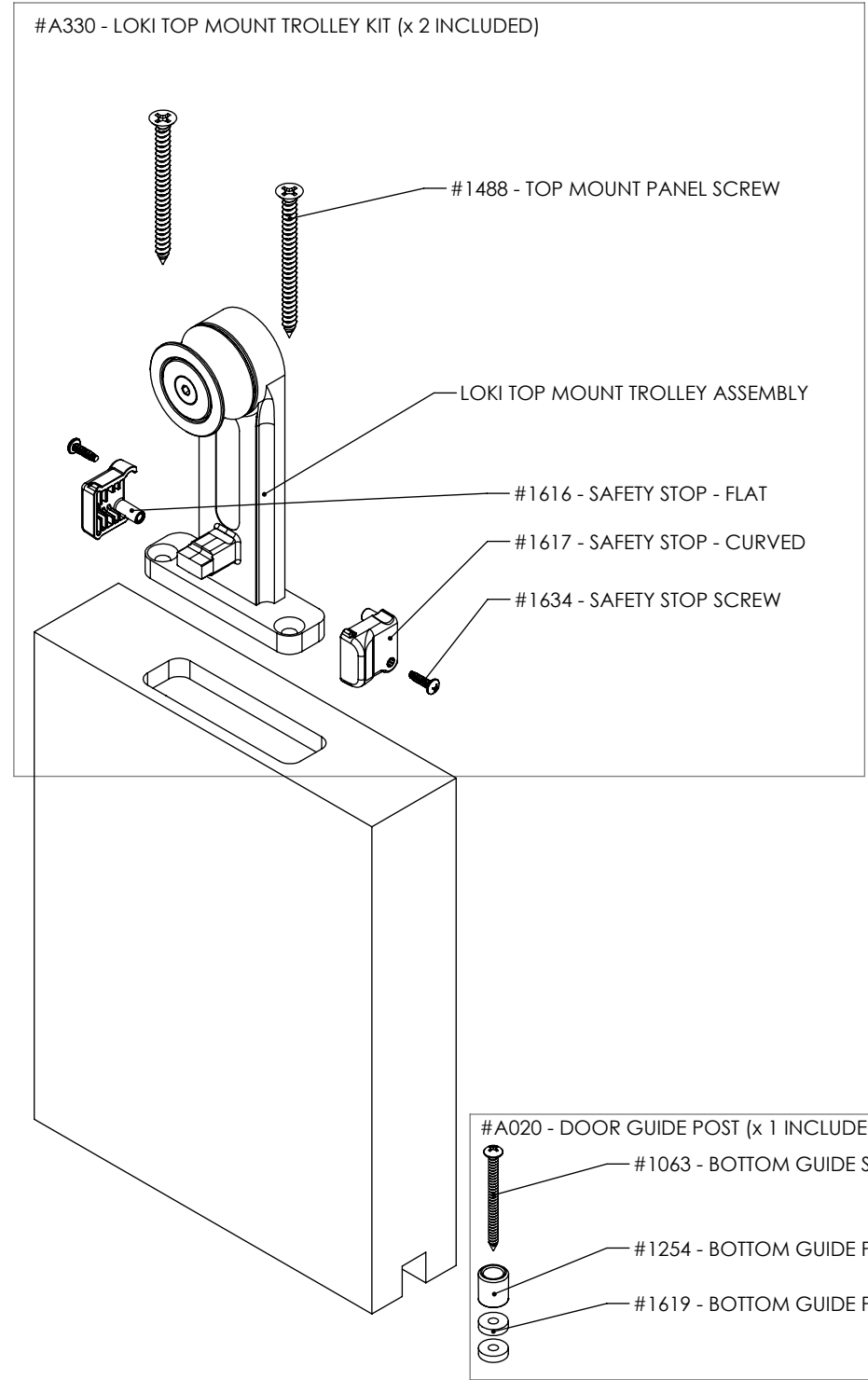
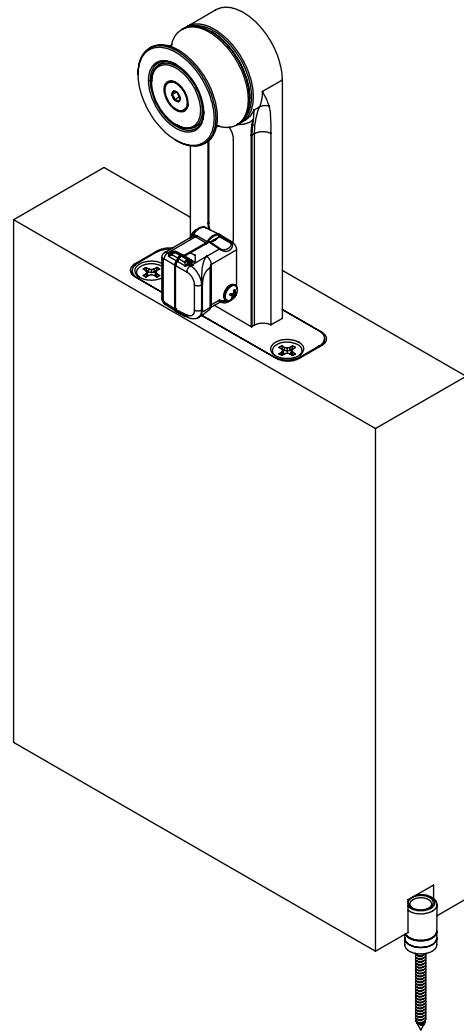
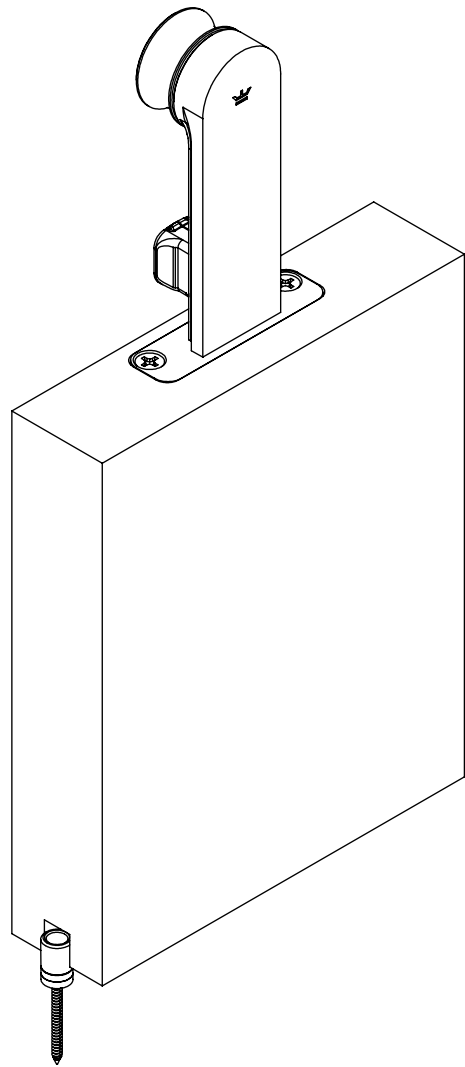

\* = THE DOOR GUIDE MAY DIFFER - MULTIPLE OPTIONS EXIST

DOCUMENT:	PRODUCT SPECIFICATIONS	DOOR APPLICATION:	SINGLE & BI-PARTING	DRAWING SCALE:	4" = 1'-0" (1:3)	KROWNLAB 2351 NW York St. Portland, OR 97210 +1 503 292 6998 www.krownlab.com support@krownlab.com
SYSTEM:	LOKI	PANEL THICKNESS:	3/4" TO 2-1/2"* (CHOOSE TOP MOUNT FOR THICKER PANELS)	UNITS:	INCHES	
MOUNTING STYLE:	FACE MOUNT	MAXIMUM WEIGHT:	UP TO 200LBS (CONTACT US FOR HEAVIER PANELS)	DATE:	3/30/2018	



\* = 2-1/2" PANEL WILL HAVE 1/4" WALL CLEARANCE.

WHAT'S INCLUDED:  
 2 x - #A331 - LOKI FACE MOUNT TROLLEY KIT  
 1 x - #A020 - DOOR GUIDE POST KIT (DOOR GUIDE MAY DIFFER - MULTIPLE OPTIONS EXIST)  
 1 x - #Txxxx - TRU-LEVEL™ TRACK SYSTEM WITH ALL MOUNTING HARDWARE (SEE SEPARATE PAGE)

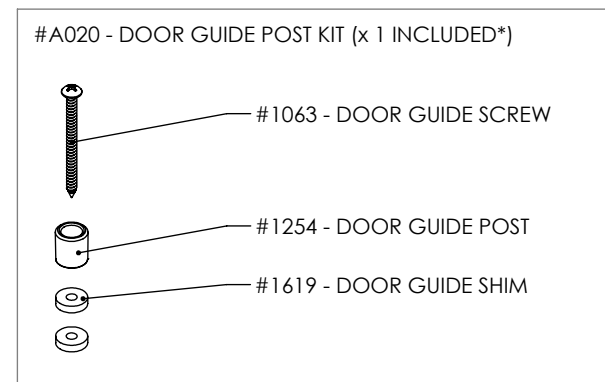
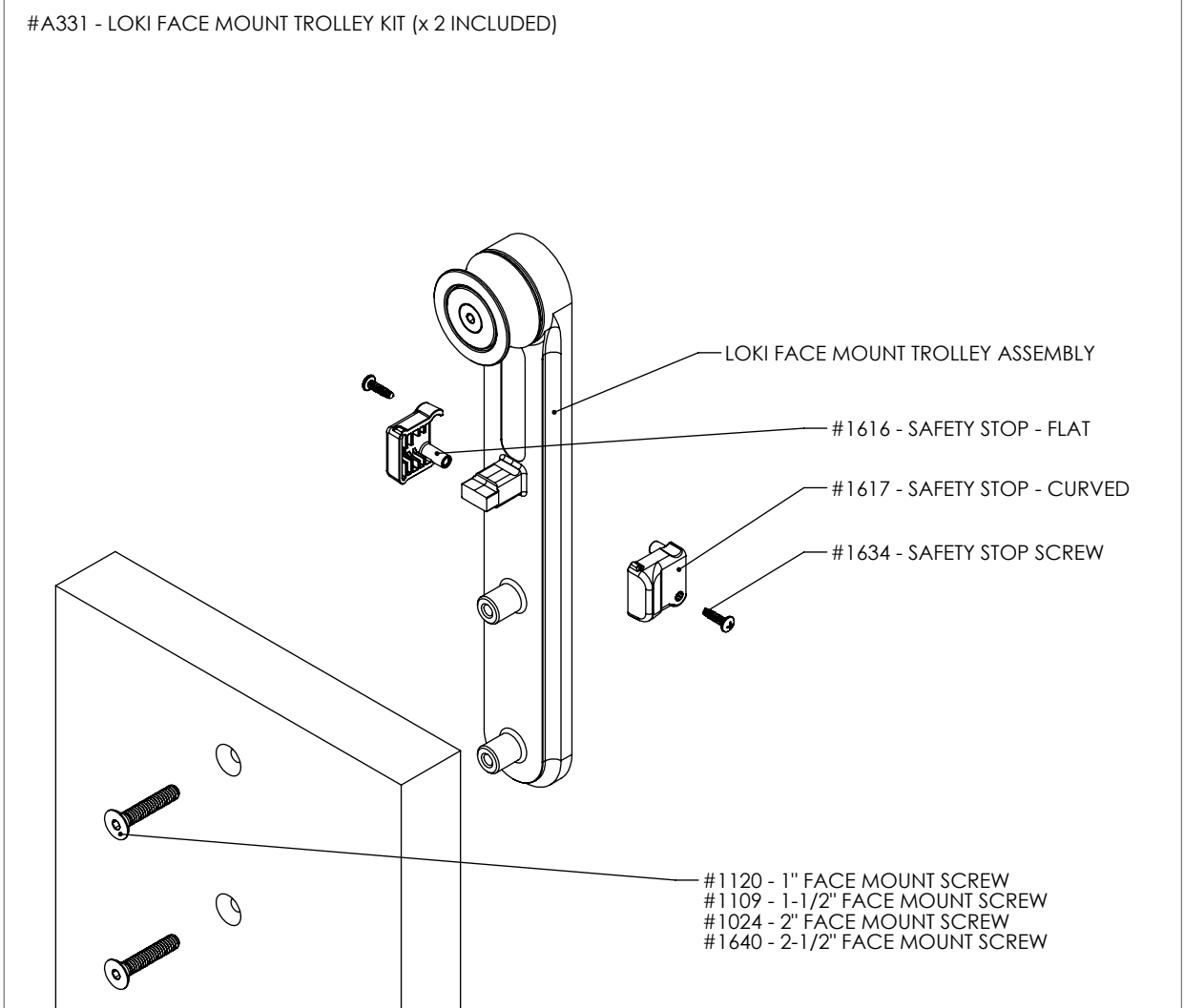
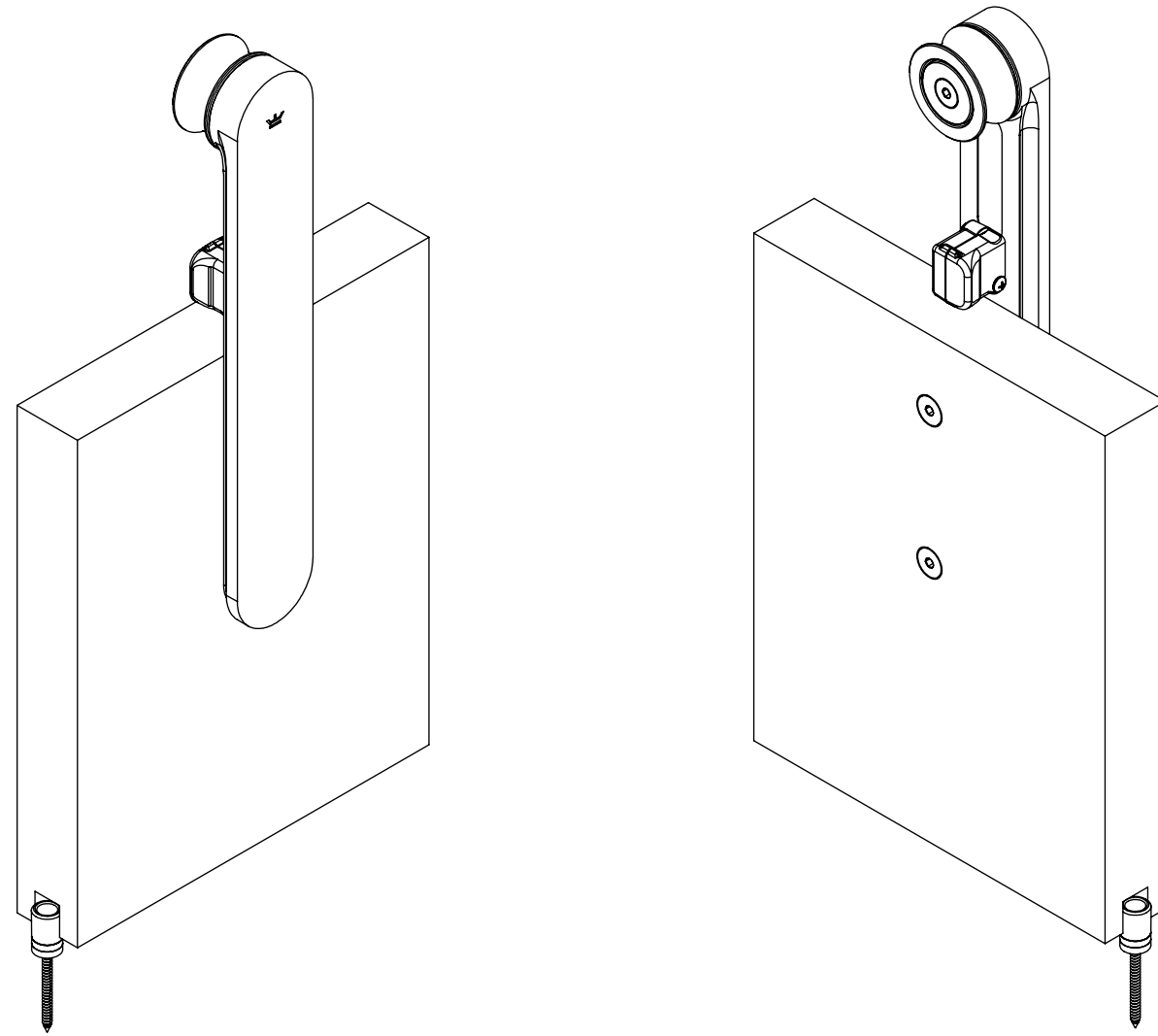

\* = THE DOOR GUIDE MAY DIFFER - MULTIPLE OPTIONS EXIST

DOCUMENT:	PRODUCT SPECIFICATIONS	DOOR APPLICATION:	SINGLE, BI-PARTING, BYPASSING	DRAWING SCALE:	4" = 1'-0" (1:3)	KROWNLAB 2351 NW York St. Portland, OR 97210 +1 503 292 6998 www.krownlab.com support@krownlab.com
SYSTEM:	LOKI	PANEL THICKNESS:	3/8" TO 1/2" (CONTACT US FOR PANELS OUTSIDE OF THIS RANGE)	UNITS:	INCHES	
MOUNTING STYLE:	GLASS MOUNT	MAXIMUM WEIGHT:	UP TO 200LBS (CONTACT US FOR HEAVIER PANELS)	DATE:	3/30/2018	



WHAT'S INCLUDED:  
 2 x - #A332 - LOKI GLASS MOUNT TROLLEY KIT  
 1 x - #A219 - DOOR GUIDE KIT (DOOR GUIDE MAY DIFFER - MULTIPLE OPTIONS EXIST)  
 1 x - #Txxxx - TRU-LEVEL™ TRACK SYSTEM WITH ALL MOUNTING HARDWARE (SEE SEPARATE PAGE)

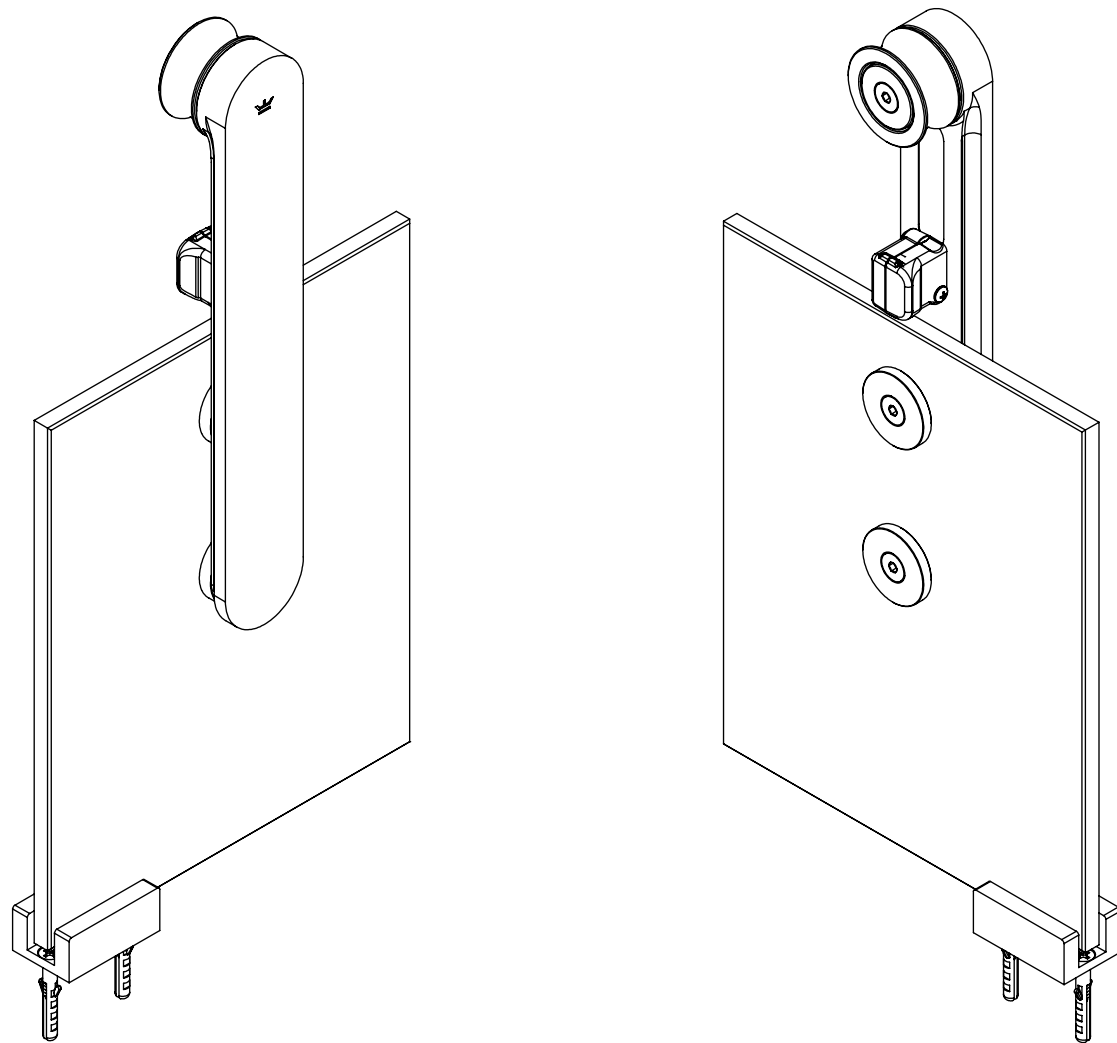

#A332 - LOKI GLASS MOUNT TROLLEY KIT (x 2 INCLUDED)

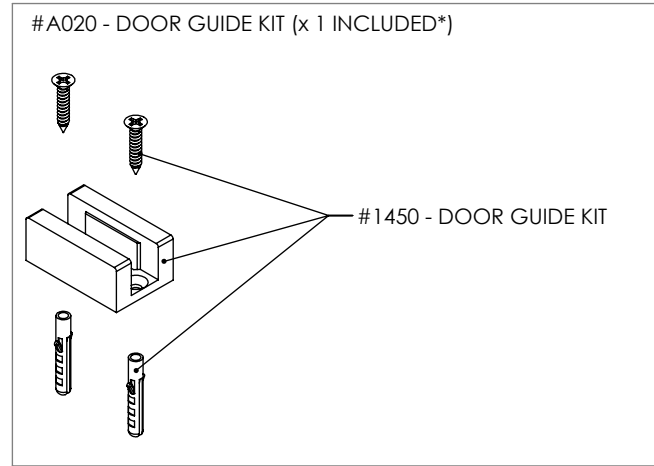
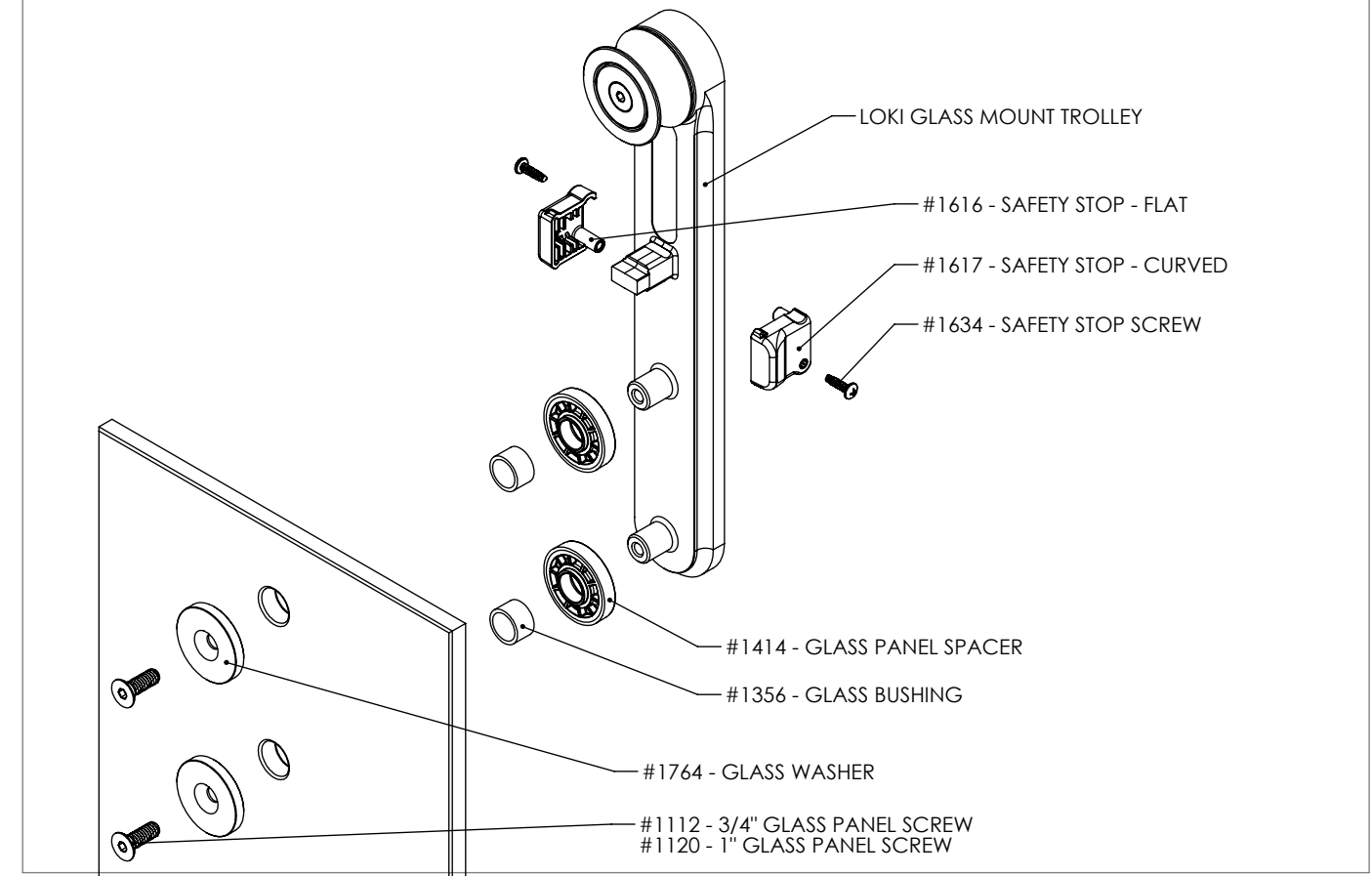

\* = THE DOOR GUIDE MAY DIFFER - MULTIPLE OPTIONS EXIST

DOCUMENT:	PRODUCT SPECIFICATIONS - DOOR CONFIGURATIONS	DOOR APPLICATION:	SINGLE, BI-PARTING, BYPASSING	DRAWING SCALE:	3/8" = 1'-0" (1:32)	KROWNLAB 2351 NW York St. Portland, OR 97210 +1 503 292 6998 www.krownlab.com support@krownlab.com
SYSTEM:	TRU-LEVEL™ TRACK	PANEL THICKNESS:	TROLLEY SYSTEM OR TRACK CONFIGURATION DEPENDENT	UNITS:	INCHES	
MOUNTING STYLE:	FRAMED WALL	MAXIMUM WEIGHT:	TROLLEY SYSTEM OR TRACK CONFIGURATION DEPENDENT	DATE:	3/12/2018	



SINGLE

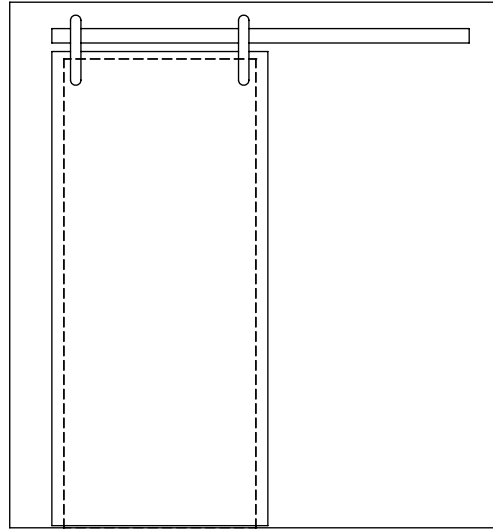

BI-PARTING

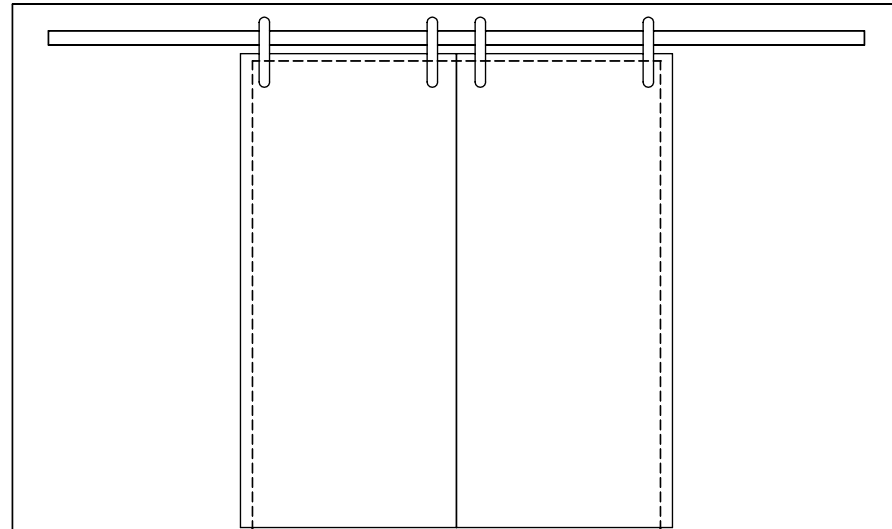

BYPASSING

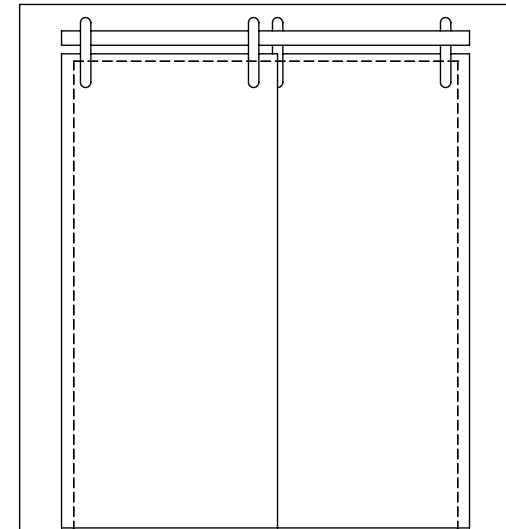

BI-PARTING-BYPASSING

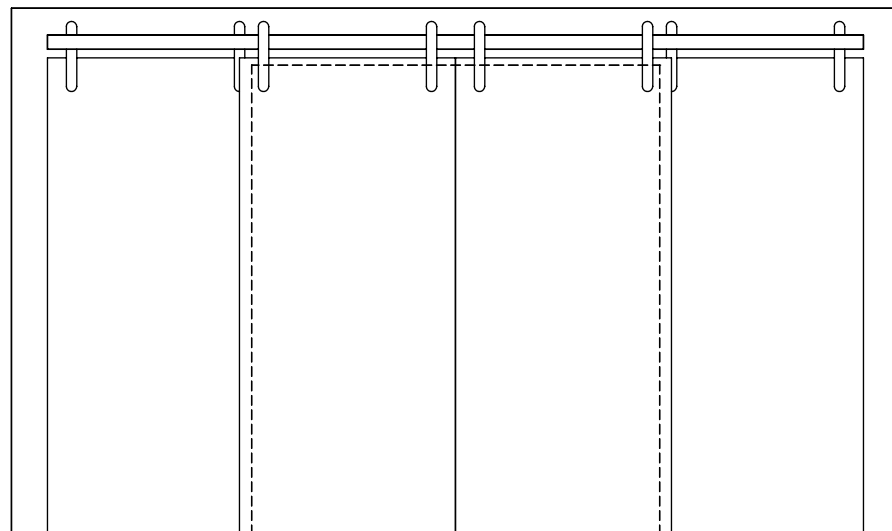

BYPASSING STACKED

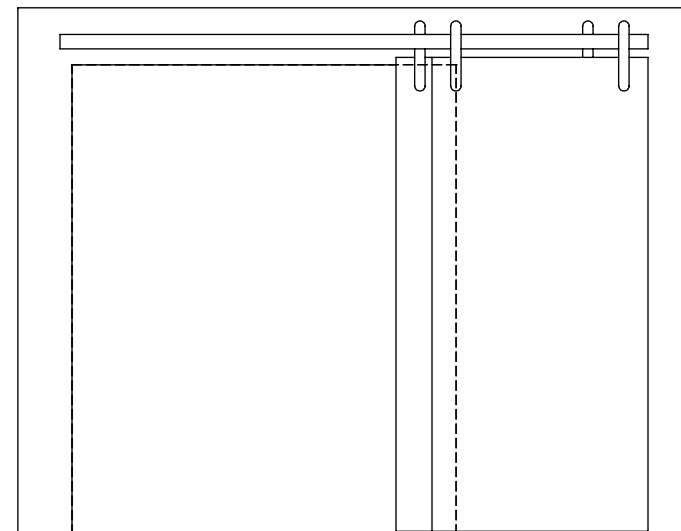

DOCUMENT: PRODUCT SPECIFICATIONS	DOOR APPLICATION: SINGLE, BI-PARTING, BYPASSING	DRAWING SCALE: 6" = 1'-0" (1:2)	KROWNLAB 2351 NW York St. Portland, OR 97210 +1 503 292 6998 www.krownlab.com support@krownlab.com
SYSTEM: TRU-LEVEL™ TRACK	PANEL THICKNESS: TROLLEY SYSTEM DEPENDENT	UNITS: INCHES	
MOUNTING STYLE: FRAMED WALL	MAXIMUM WEIGHT: TROLLEY SYSTEM DEPENDENT	DATE: 3/12/2018	



WHAT'S INCLUDED:  
 1 x - #Txxxx - TRU-LEVEL™ TRACK SYSTEM WITH ALL MOUNTING HARDWARE:  
 X x - #A252 - STANDARD TRACK MOUNTING KIT  
 2 x - #A214 - DOOR STOP KIT  
 X x - #A213 - TRACK CONNECTOR KIT (1 x PER TRACK JOINT INLCUED)

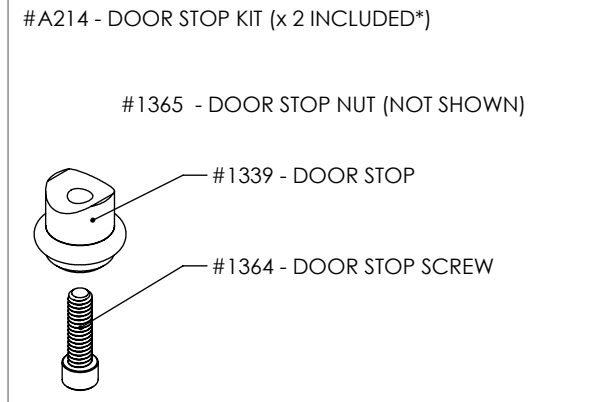

\* = THE DOOR STOP MAY DIFFER - MULTIPLE OPTIONS EXIST  
 VISIT WWW.KROWNLAB.COM FOR ALL OPTIONS

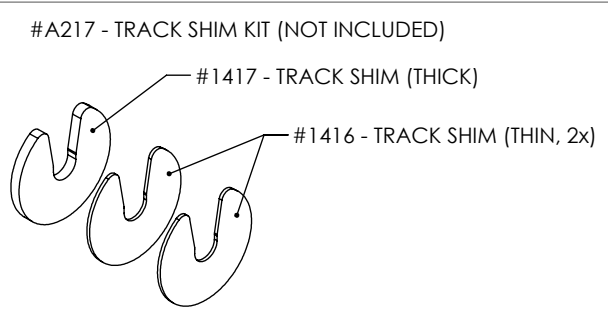

TRACK SHIMS ARE DESIGNED TO BE INSTALLED AGAINST TRACK

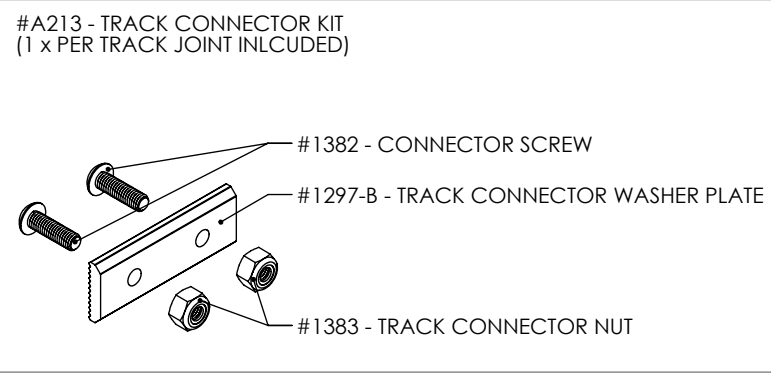

#Txxxx - TRU-LEVEL™ TRACK SYSTEM

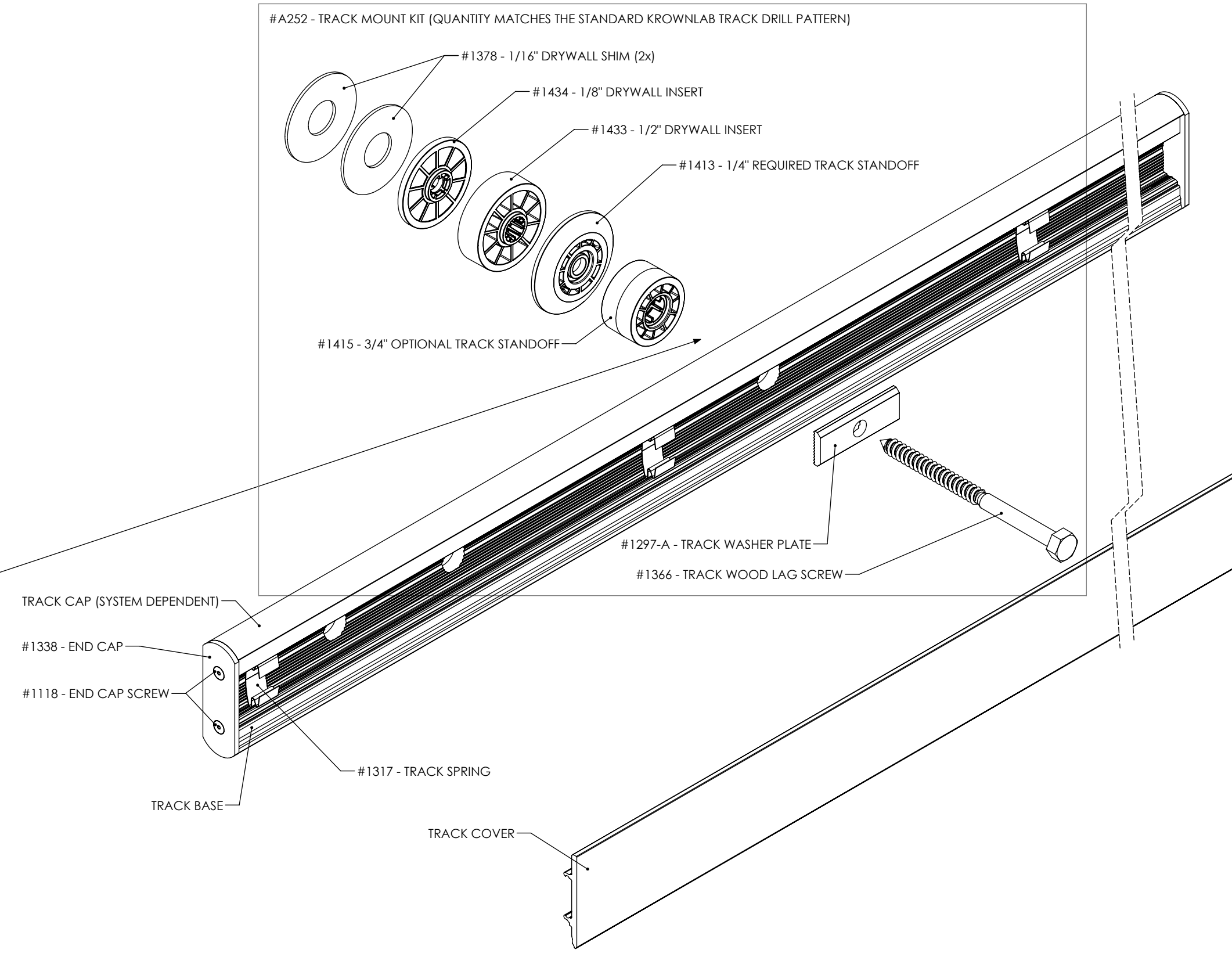



DOCUMENT:	PRODUCT SPECIFICATIONS - STANDARD TRACK MOUNTING POINT	DOOR APPLICATION:	SINGLE, BI-PARTING, BYPASSING	DRAWING SCALE:	6" = 1'-0" (1:2)	KROWNLAB 2351 NW York St. Portland, OR 97210 +1 503 292 6998 www.krownlab.com support@krownlab.com
SYSTEM:	TRU-LEVEL™ TRACK	PANEL THICKNESS:	TROLLEY SYSTEM DEPENDENT	UNITS:	INCHES	
MOUNTING STYLE:	FRAMED WALL	MAXIMUM WEIGHT:	TROLLEY SYSTEM DEPENDENT	DATE:	3/12/2018	

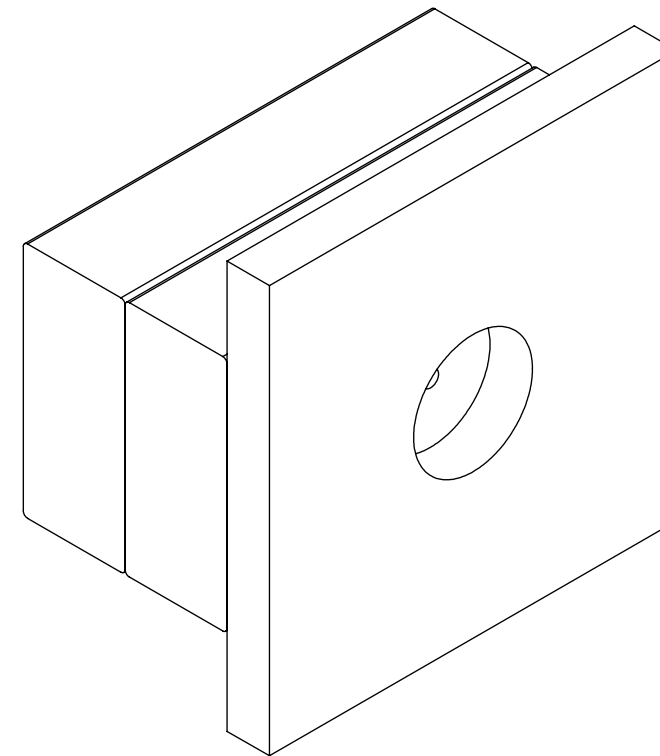
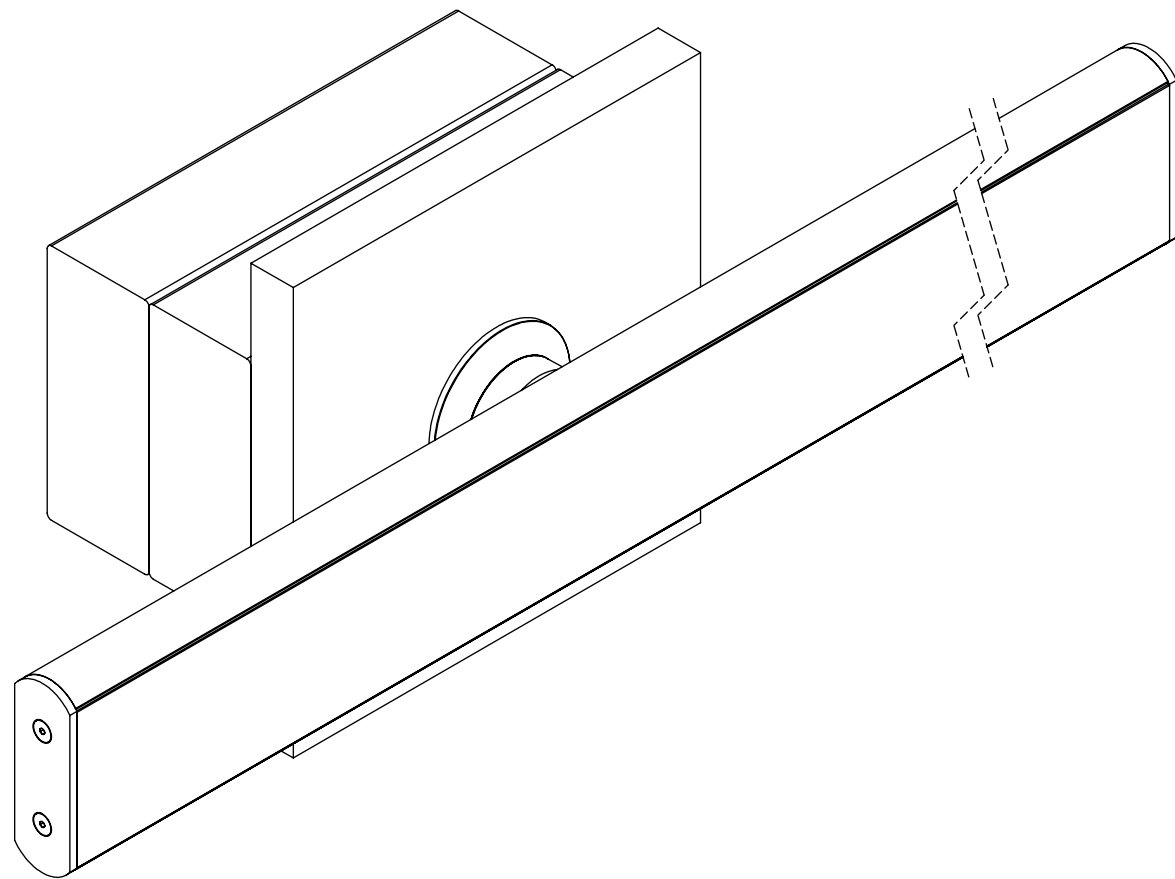
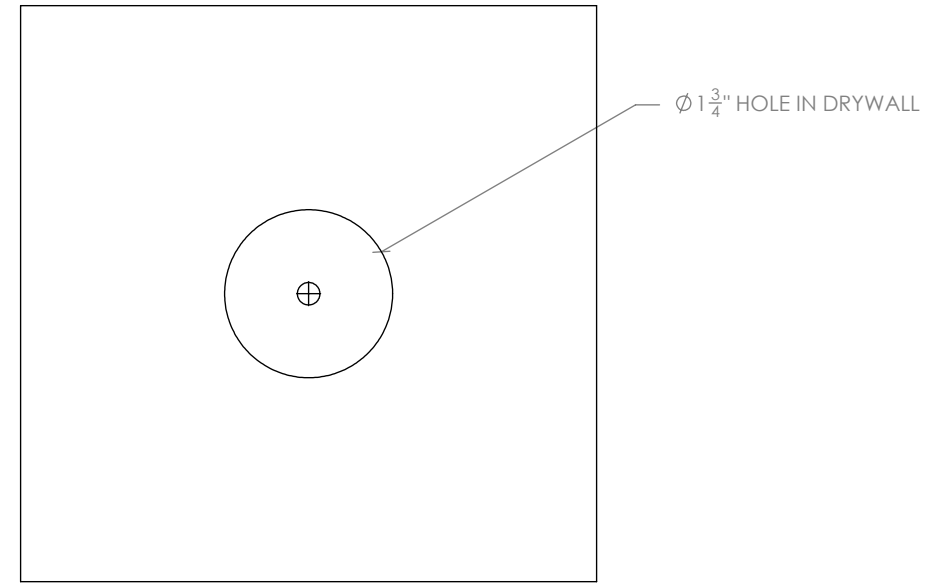
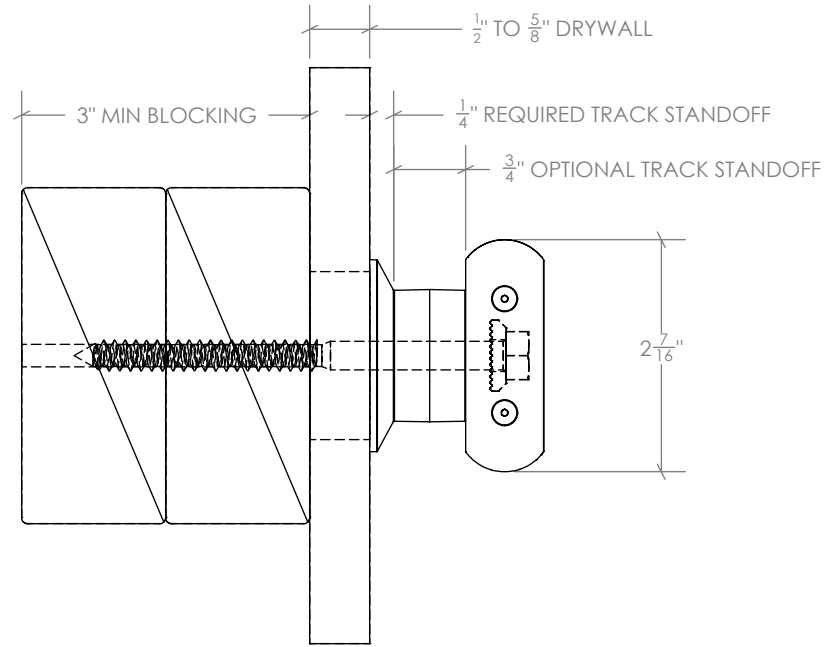

DOCUMENT:	PRODUCT SPECIFICATIONS - TRACK CONNECTOR	DOOR APPLICATION:	SINGLE & BI-PARTING	DRAWING SCALE:	6" = 1'-0" (1:2)	KROWNLAB 2351 NW York St. Portland, OR 97210 +1 503 292 6998 www.krownlab.com support@krownlab.com
SYSTEM:	TRU-LEVEL™ TRACK	PANEL THICKNESS:	TROLLEY SYSTEM DEPENDENT	UNITS:	INCHES	
MOUNTING STYLE:	ALL WALL TYPES	MAXIMUM WEIGHT:	TROLLEY SYSTEM DEPENDENT	DATE:	3/12/2018	

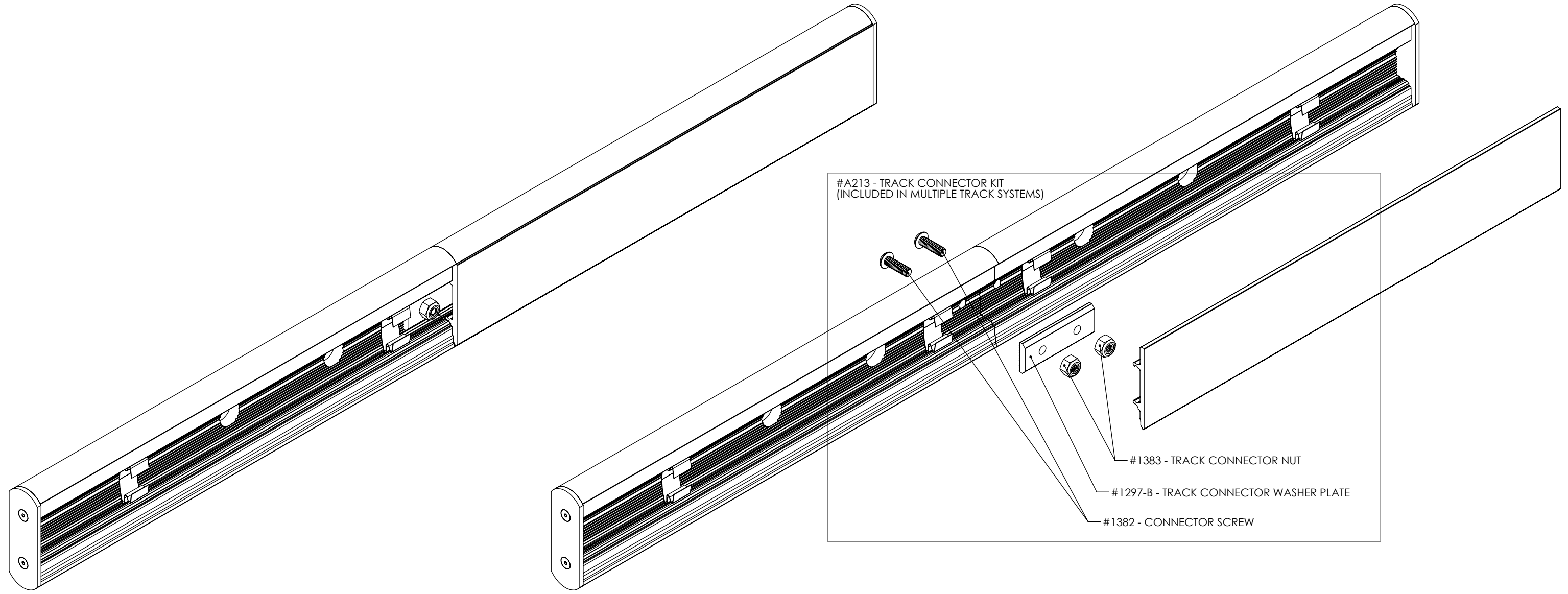
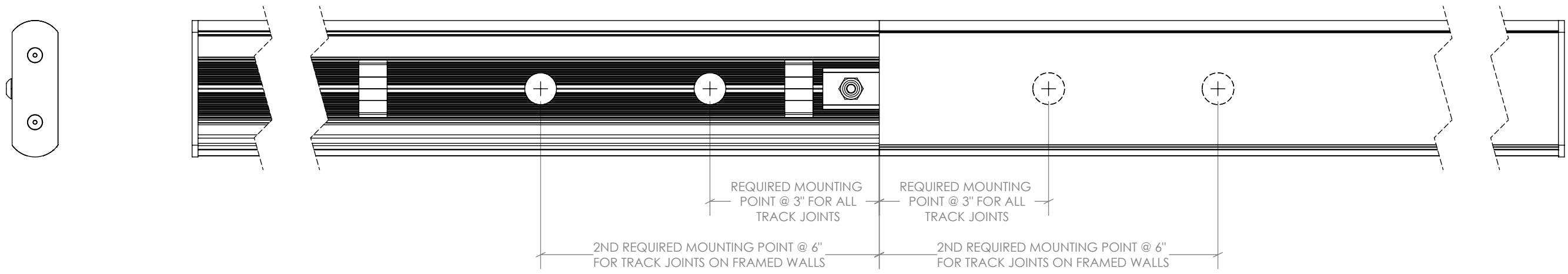

DOCUMENT: PRODUCT SPECIFICATIONS - PERPENDICULAR TRACK MOUNTING POINT  
 SYSTEM: TRU-LEVEL™ TRACK  
 MOUNTING STYLE: FRAMED WALL

DOOR APPLICATION: SINGLE, BI-PARTING, BYPASSING  
 PANEL THICKNESS: TROLLEY SYSTEM DEPENDENT  
 MAXIMUM WEIGHT: TROLLEY SYSTEM OR TRACK CONFIGURATION DEPENDENT

DRAWING SCALE: 3/4" = 1'-0" (1:16)  
 UNITS: INCHES  
 DATE: 3/12/2018

KROWNLAB  
 2351 NW York St.  
 Portland, OR 97210  
 +1 503 292 6998  
 www.krownlab.com  
 support@krownlab.com

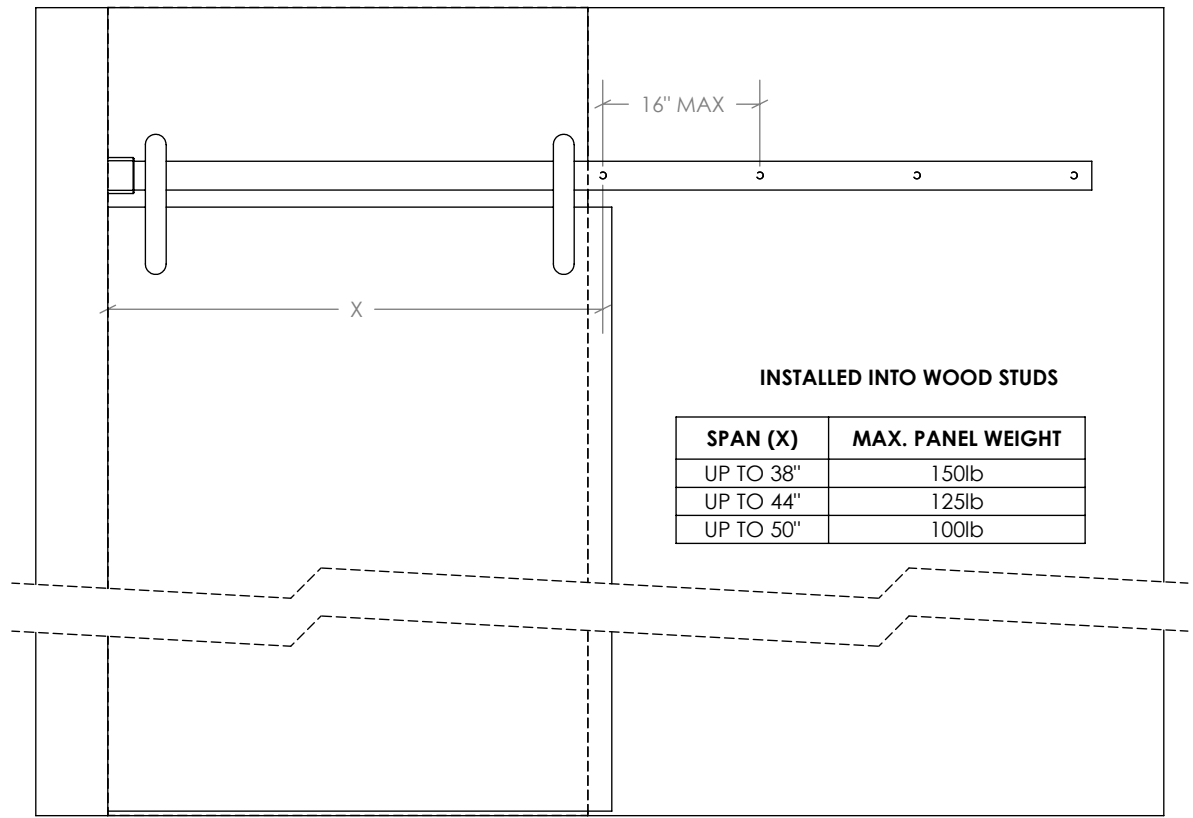
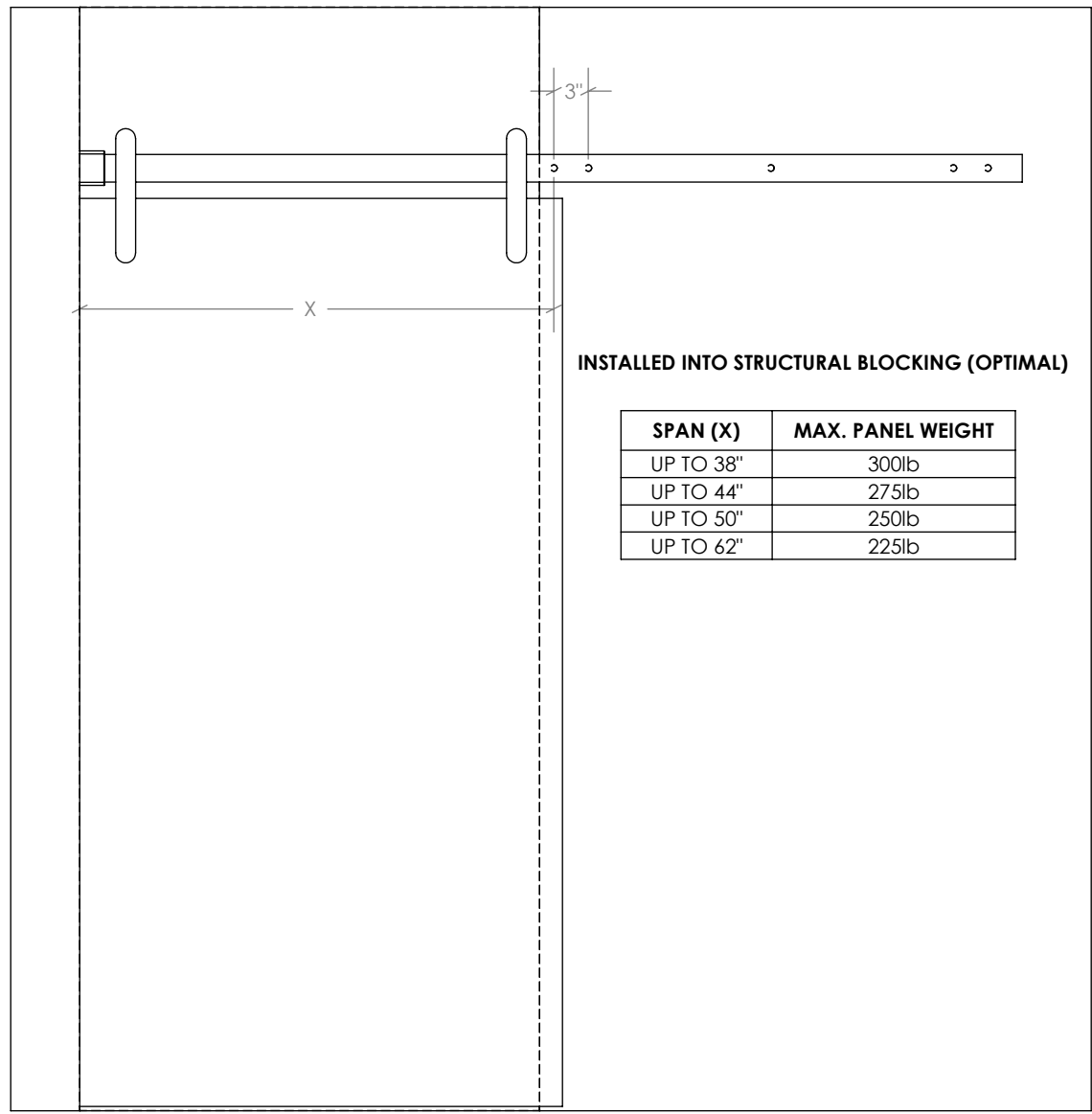
SCALE: 3" = 1'-0" (1:4)

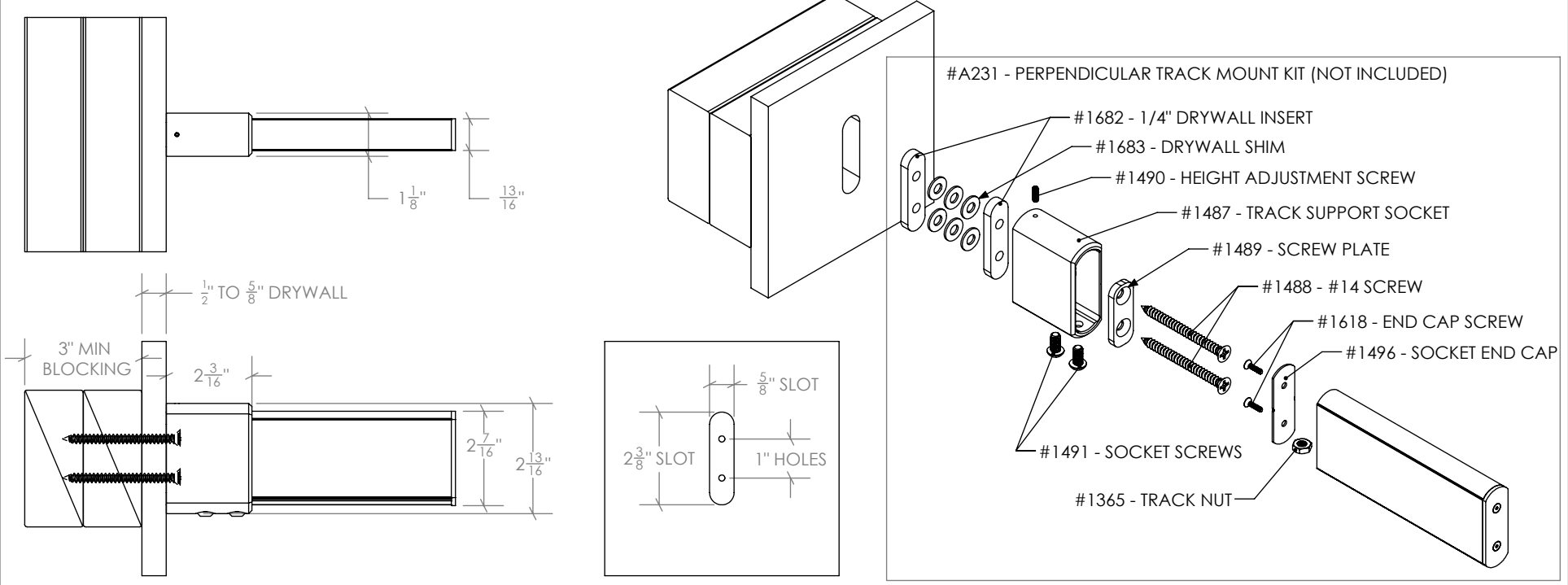

DOCUMENT: PRODUCT SPECIFICATIONS - BYPASSING WITH CENTER MOUNT  
 SYSTEM: TRU-LEVEL™ TRACK  
 MOUNTING STYLE: FRAMED WALL

DOOR APPLICATION: BYPASSING  
 PANEL THICKNESS: TROLLEY SYSTEM OR BYPASSING DEPENDENT  
 MAXIMUM WEIGHT: TROLLEY SYSTEM OR TRACK LENGTH DEPENDENT

DRAWING SCALE: 1" = 1'-0" (1:12)  
 UNITS: INCHES  
 DATE: 3/12/2018

KROWNLAB  
 2351 NW York St.  
 Portland, OR 97210  
 +1 503 292 6998  
 www.krownlab.com  
 support@krownlab.com

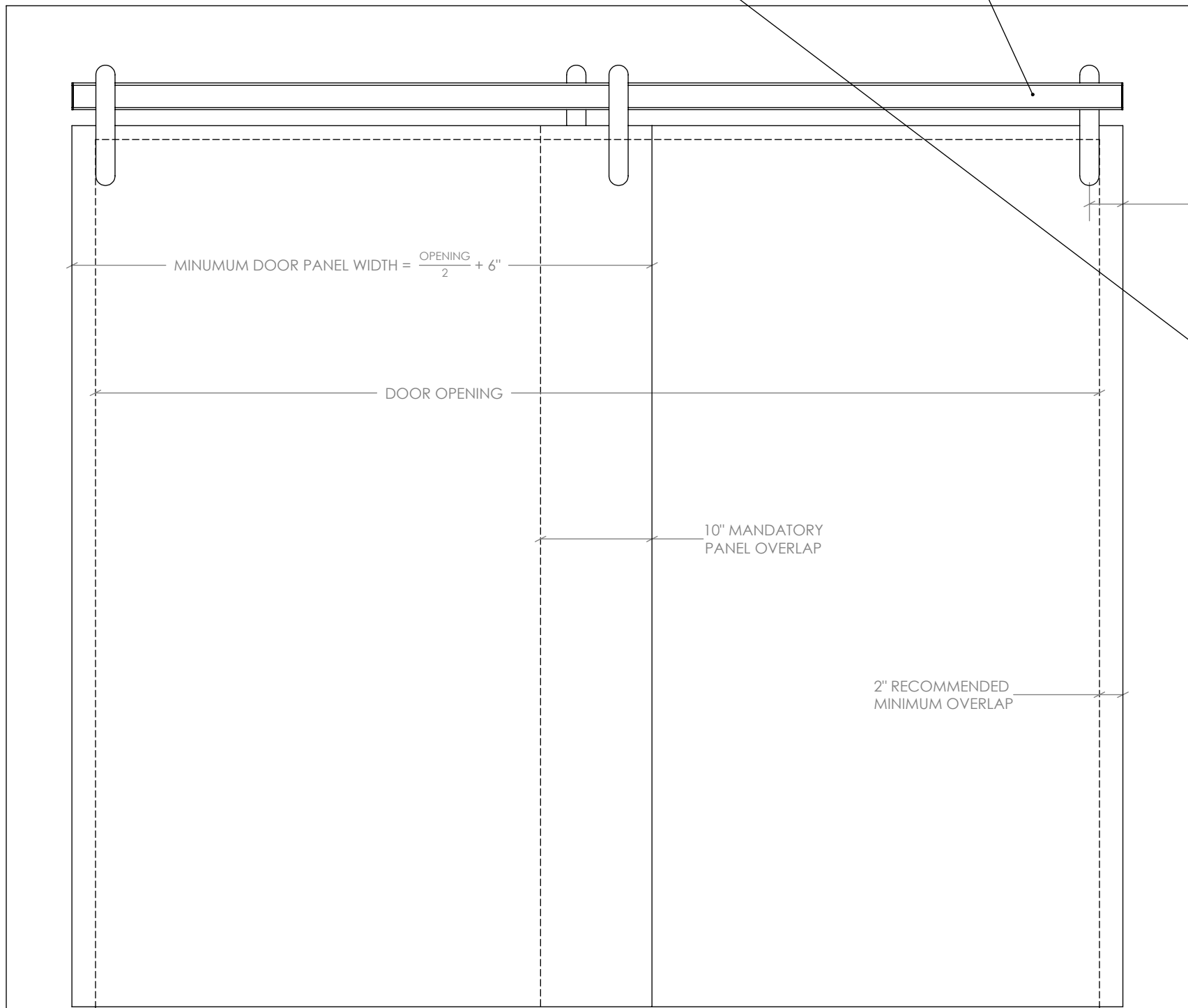
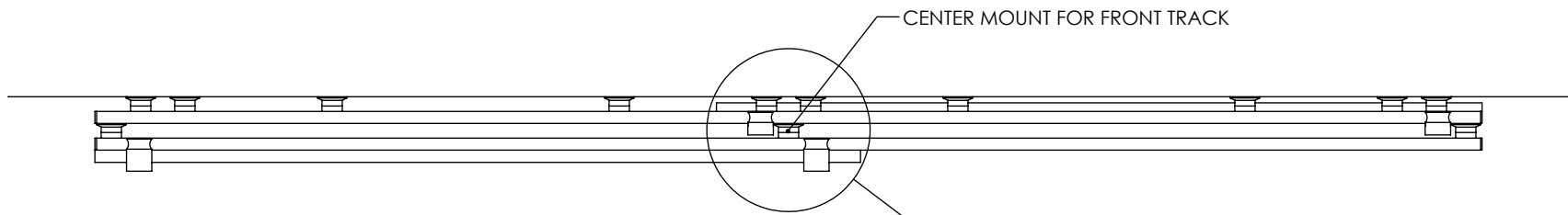
TRACK LENGTH	MAX. PANEL WEIGHT*
UP TO 9FT	225lb
UP TO 11FT	200lb
UP TO 12FT	175lb
UP TO 13FT	150lb

\*EACH PANEL

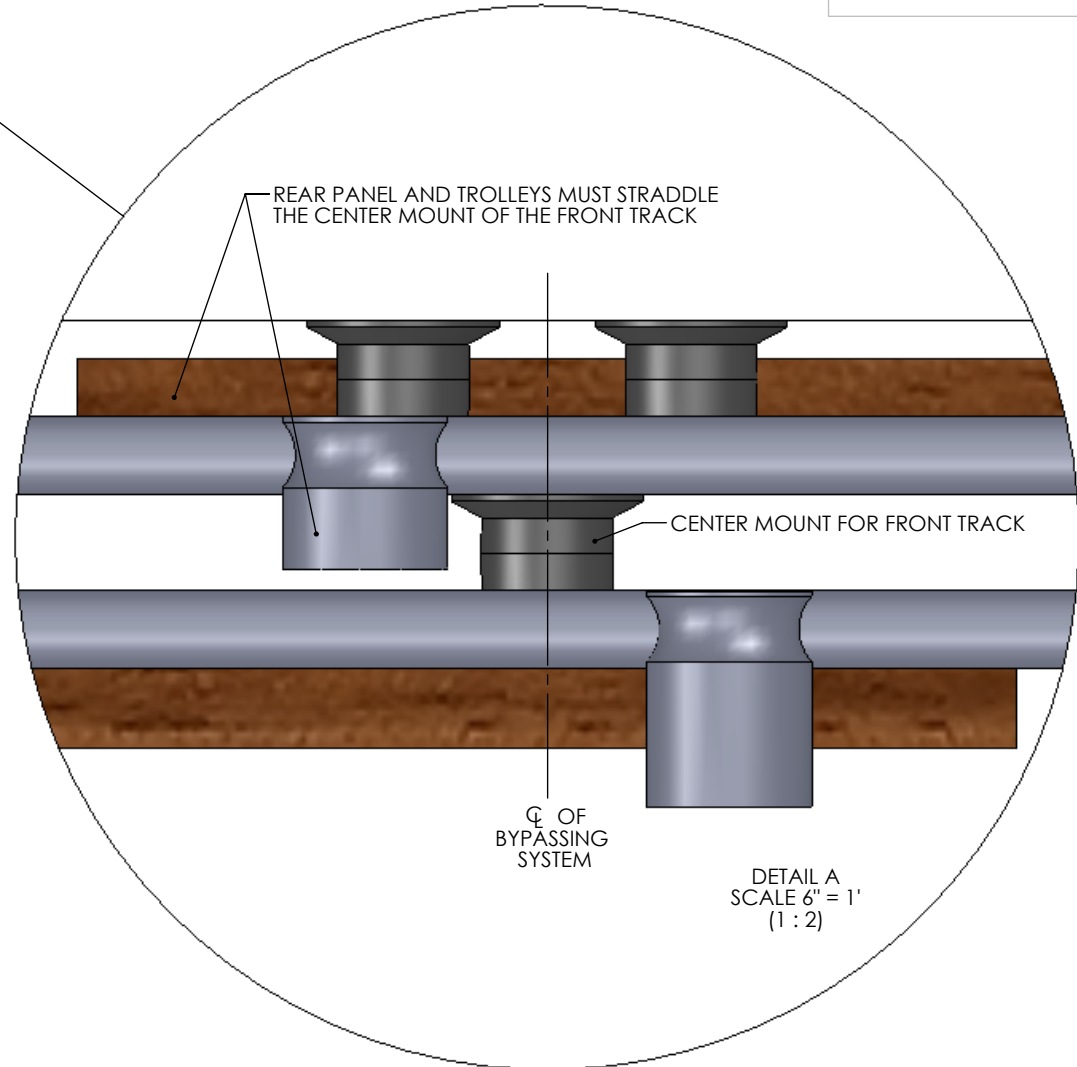
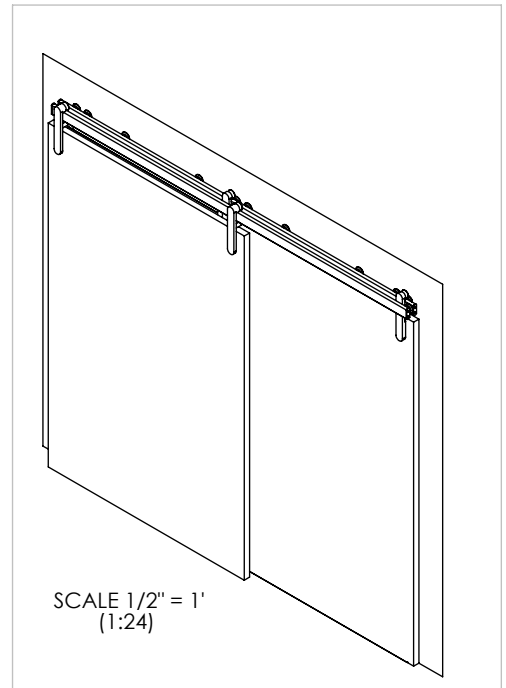

DOCUMENT: PRODUCT SPECIFICATIONS - BYPASSING WITHOUT CENTER MOUNT  
 SYSTEM: TRU-LEVEL™ TRACK  
 MOUNTING STYLE: FRAMED WALL

DOOR APPLICATION: BYPASSING  
 PANEL THICKNESS: TROLLEY SYSTEM OR BYPASSING DEPENDENT  
 MAXIMUM WEIGHT: TRACK LENGTH DEPENDENT

DRAWING SCALE: 1" = 1'-0" (1:12)  
 UNITS: INCHES  
 DATE: 3/12/2018

KROWNLAB  
 2351 NW York St.  
 Portland, OR 97210  
 +1 503 292 6998  
 www.krownlab.com  
 support@krownlab.com

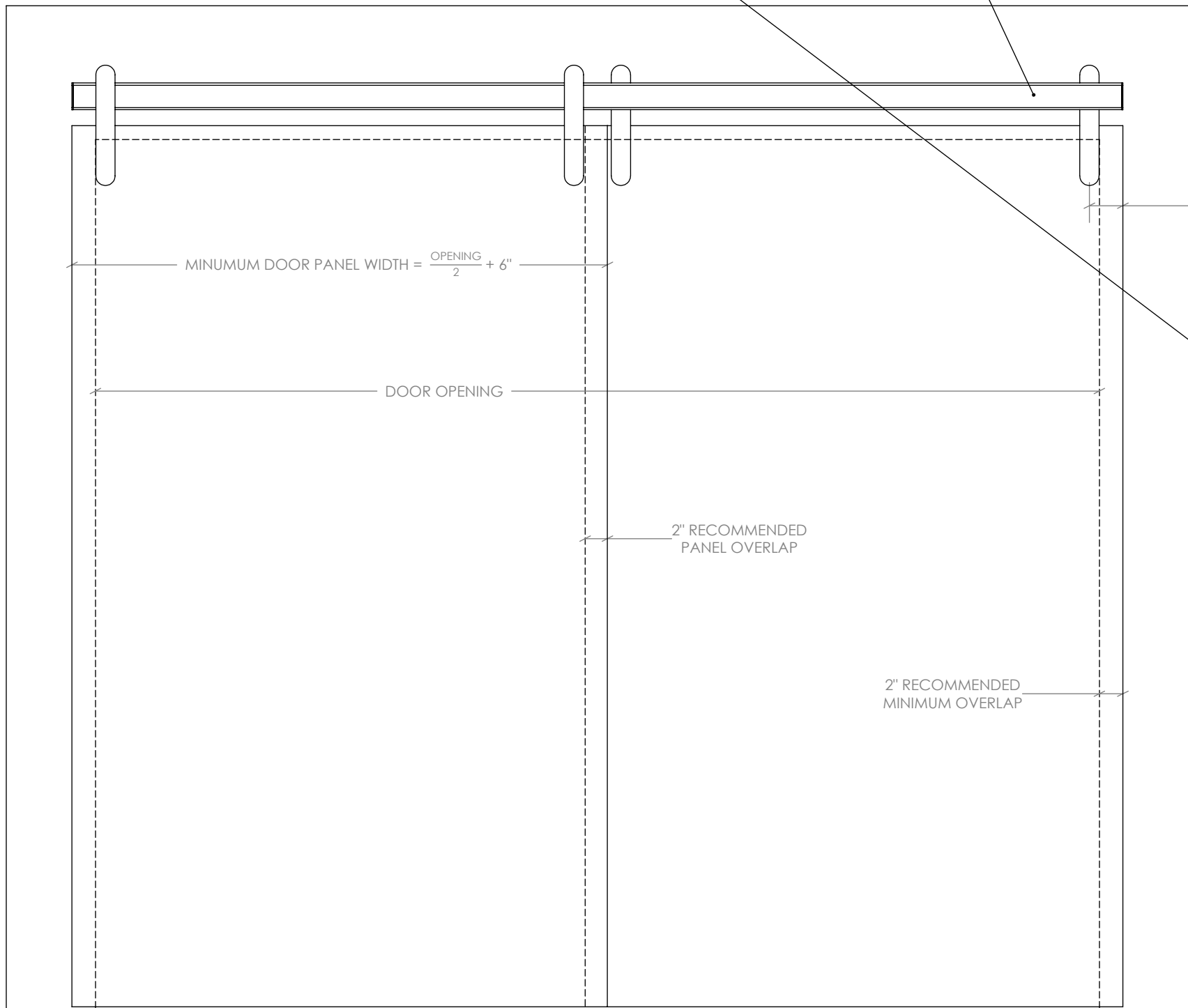
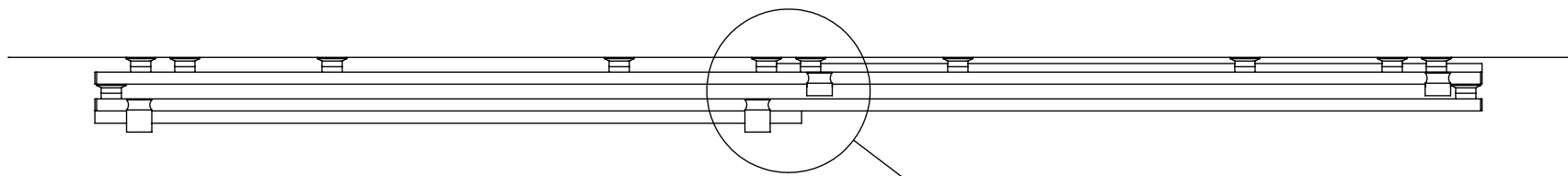
TRACK LENGTH	MAX. PANEL WEIGHT*
UP TO 4FT	150lb
UP TO 5FT	125lb
UP TO 6FT	85lb

\*EACH PANEL

3" MINIMUM FOR BYPASSING SYSTEMS

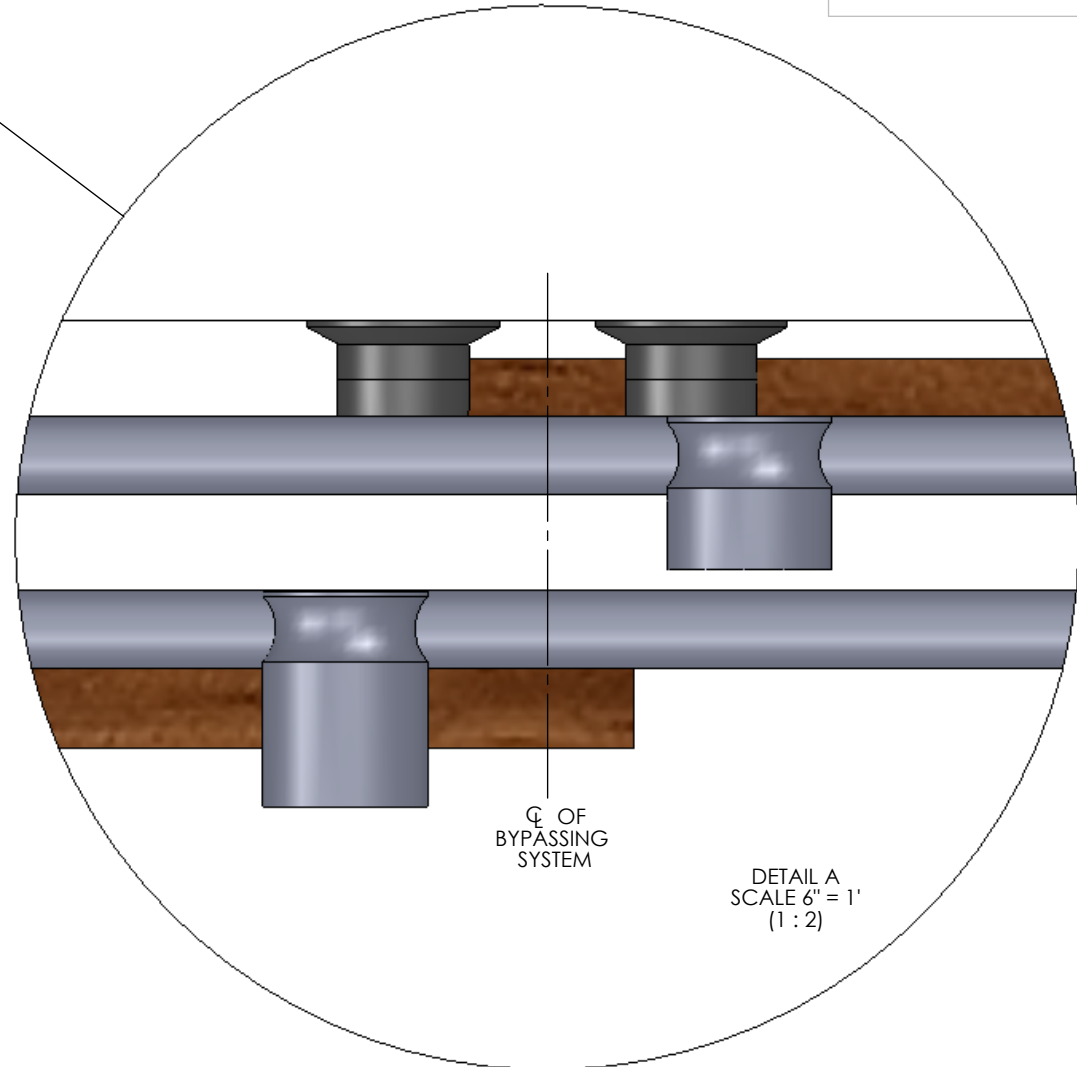
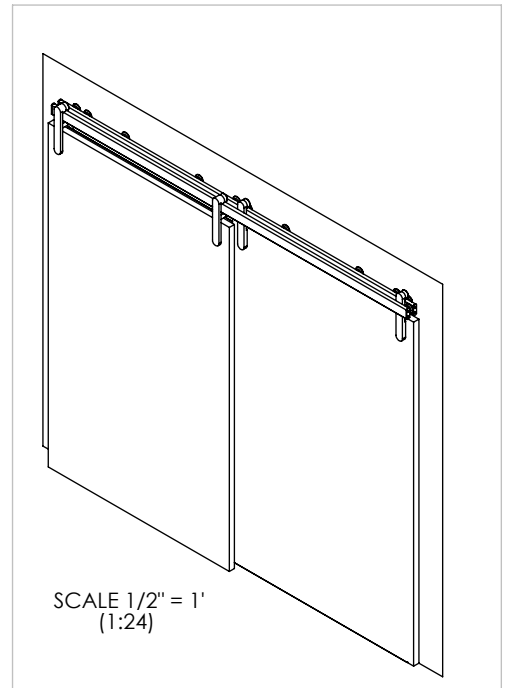

DOCUMENT: PRODUCT SPECIFICATIONS - BYPASSING PANEL CLEARANCE  
 SYSTEM: TRU-LEVEL™ TRACK  
 MOUNTING STYLE: FRAMED WALL

DOOR APPLICATION: BYPASSING  
 PANEL THICKNESS: TROLLEY SYSTEM OR BYPASSING DEPENDENT  
 MAXIMUM WEIGHT: SYSTEM DEPENDENT AND TRACK LENGTH DEPENDENT

DRAWING SCALE: 1" = 1'-0" (1:2)  
 UNITS: INCHES  
 DATE: 3/12/2018

KROWNLAB  
 2351 NW York St.  
 Portland, OR 97210  
 +1 503 292 6998  
 www.krownlab.com  
 support@krownlab.com

**KROWNLAB**  
 1995 - PRESENT

MOUNTING STYLE	PANEL THICKNESS*
TOP MOUNT	1-3/8" TO 2-1/2"
FACE MOUNT**	3/4" TO 1-3/8"
GLASS MOUNT	3/8" - 1/2"

\*NOT ACCOUNTING FOR BASEBOARD (IF EXISTING) OR OPTIONAL DOOR PULLS  
 \*\*ODEN AND BALDUR ONLY

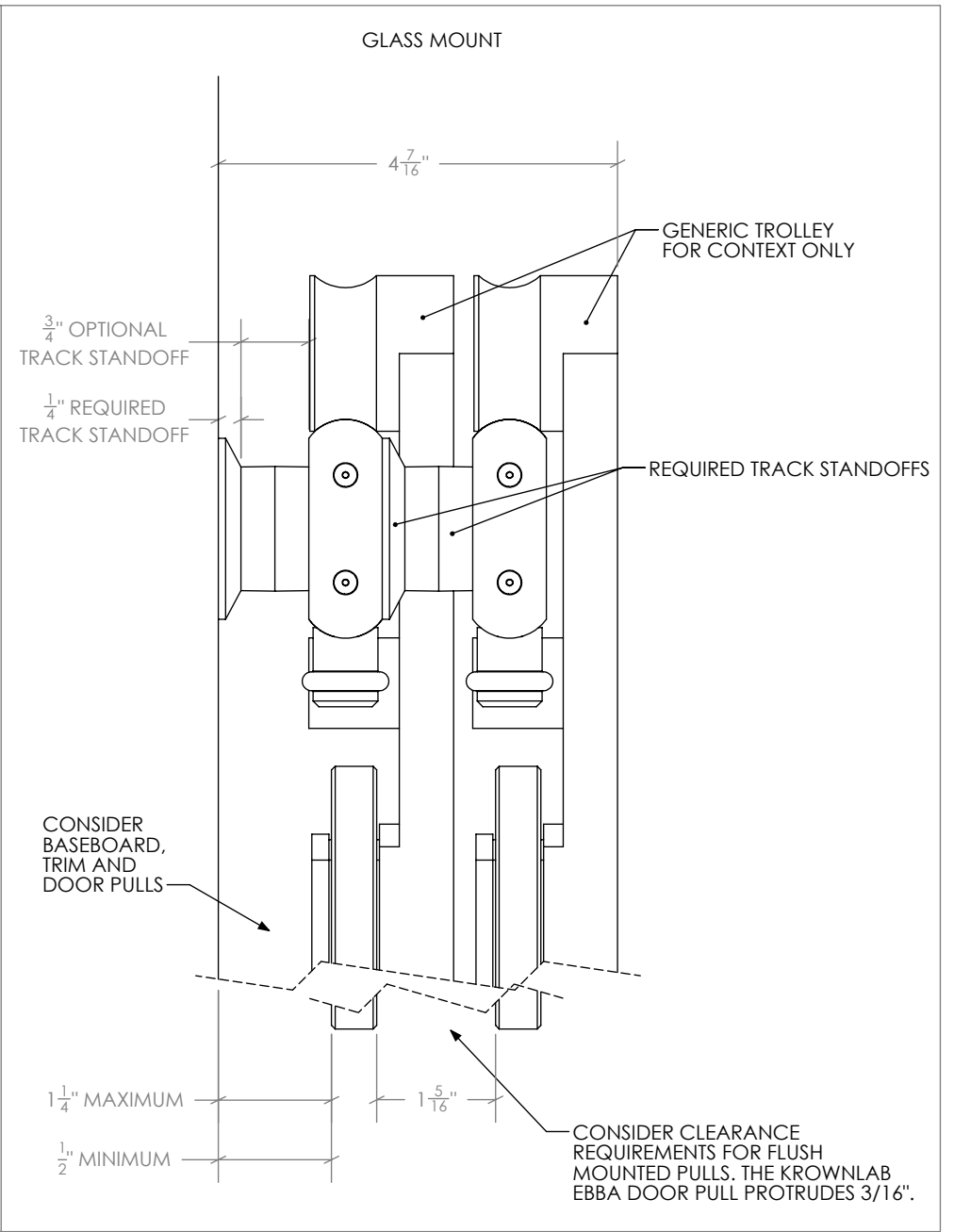
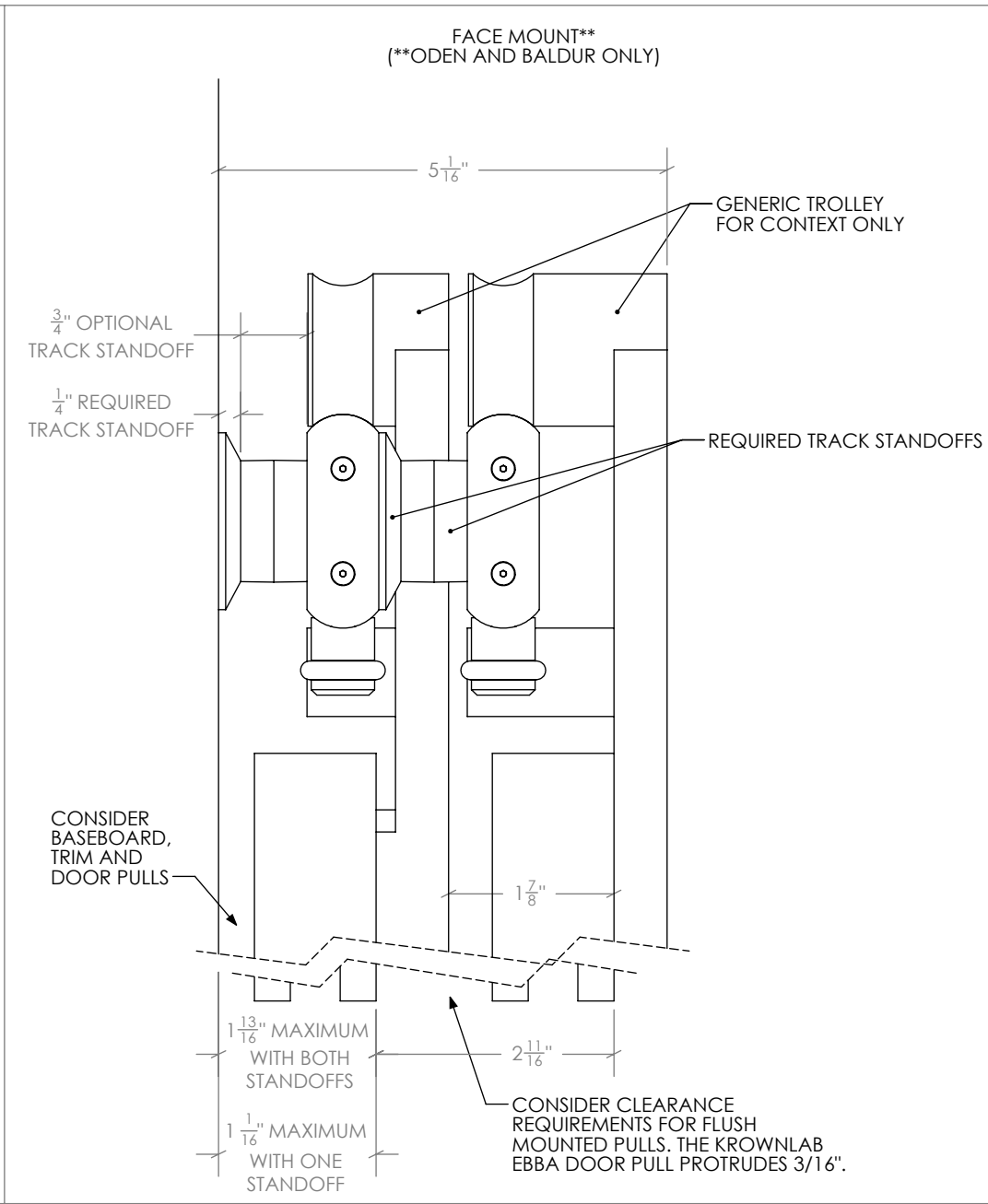
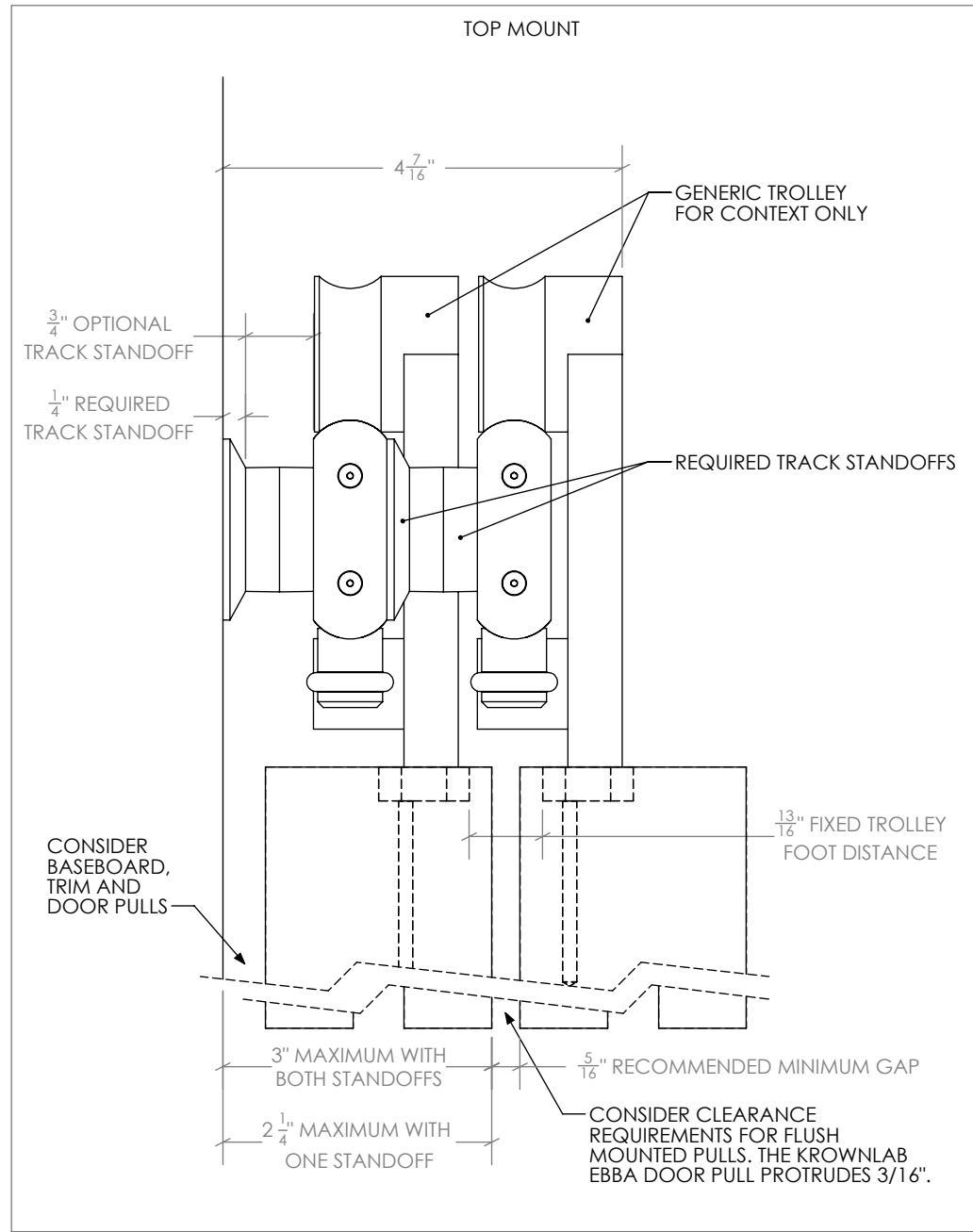

DOCUMENT:	PRODUCT SPECIFICATIONS - UNDRILLED TRACK DRILL PATTERN GUIDE	DOOR APPLICATION:	SINGLE & BI-PARTING	DRAWING SCALE:	1" = 1'-0" (1:12)	KROWNLAB 2351 NW York St. Portland, OR 97210 +1 503 292 6998 www.krownlab.com support@krownlab.com	
SYSTEM:	TRU-LEVEL™ TRACK	PANEL THICKNESS:	TROLLEY SYSTEM DEPENDENT	UNITS:	INCHES		
MOUNTING STYLE:	FRAMED WALL	MAXIMUM WEIGHT:	SEE BELOW	DATE:	3/12/2018		

STUD DRILL PATTERN: (250LB MAX\* PER TRACK)

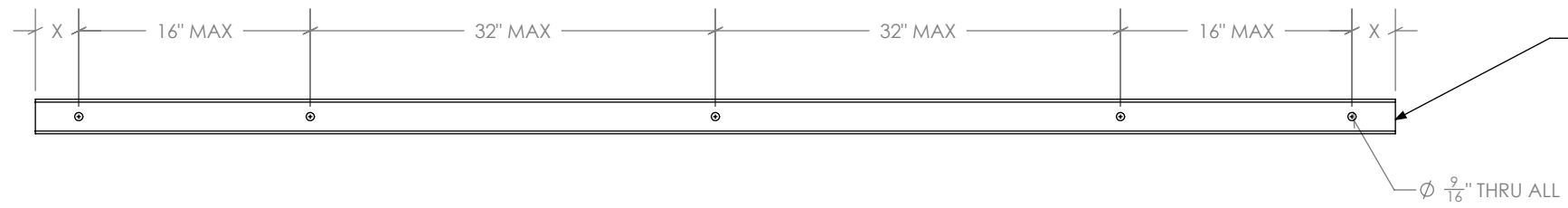

CONNECTING MULTIPLE TRACKS REQUIRE SPECIAL DRILL PATTERN AT JOINT. SEE TRACK CONNECTOR PAGE FOR DETAILS.

PANEL WEIGHT	X	MOUNTING POINTS
UP TO 100 LBS	5"	3 MINIMUM
101 TO 200 LBS	4"	4 MINIMUM
201 TO 250 LBS	3"	5 MINIMUM

"X" IS THE MAXIMUM LENGTH OF TRACK ALLOWED BEYOND END MOUNTING POINTS

STRUCTURAL BLOCKING DRILL PATTERN: (400LB MAX\* PER TRACK)

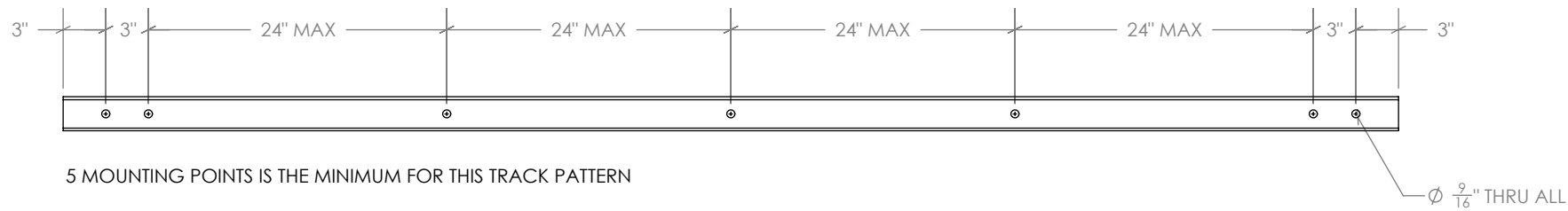

5 MOUNTING POINTS IS THE MINIMUM FOR THIS TRACK PATTERN

\* WEIGHT LIMIT MAY BE FURTHER RESTRICTED BY TROLLEY SYSTEM

DOCUMENT:	PRODUCT SPECIFICATIONS - BYPASSING TRACK DRILL PATTERN GUIDE	DOOR APPLICATION:	BYPASSING	DRAWING SCALE:	1" = 1'-0" (1:12)	KROWNLAB 2351 NW York St. Portland, OR 97210 +1 503 292 6998 www.krownlab.com support@krownlab.com
SYSTEM:	TRU-LEVEL™ TRACK	PANEL THICKNESS:	TROLLEY SYSTEM OR BYPASSING DEPENDENT	UNITS:	INCHES	
MOUNTING STYLE:	FRAMED WALL	MAXIMUM WEIGHT:	TRACK CONFIGURATION, TRACK LENGTH OR TROLLEY SYSTEM DEPENDENT	DATE:	3/12/2018	



BYPASSING TRACKS ARE ONLY AVAILABLE MADE-TO-MEASURE.  
 KROWNLAB WILL CONFIGURE THE FRONT AND REAR TRACKS USING THE RULES BELOW:

