

INSTALLATION INSTRUCTIONS

PRODUCT: ODEN

CONFIGURATION: SINGLE DOOR

TROLLEY: GLASS MOUNT

TRACK MOUNT: GLASS

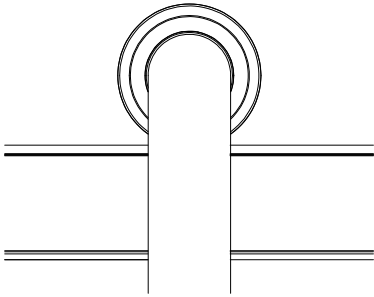

The corresponding Product Specification document is to be comprehensively reviewed prior to product installation takes place.

To deviate, or to not comprehensively and precisely follow all applicable product specifications and installation instructions can result in unsafe or hazardous site conditions that can cause bodily harm or death.

Krownlab products are covered by U.S. patents and trademarks. For more information visit www.krownlab.com

I. TOOLS + MATERIALS REQUIRED

TOOLS

- Tape measure
- Level
- Stud finder
- Ratchet and Imperial socket set
- Torque wrench capable of measuring up to 110 inch-lbs (9.5 ft-lbs)
- Imperial Allen wrench and bit set
- Standard bit kit with driver
- Power drill
- Imperial drill bit index and countersink bit
- 1-3/4" Forstner drill bit, or similar (for drywall)
- Router with grooving bit (for orders including wood door panels only)

TOOLS FOR DRILLING AND CUTTING TRACK

- Miter or chop saw and carbide toothed blade
- 9/16" metal drill bit

MATERIALS

- Blue painters tape
- Pencil or other non permanent marking tool

2. VERIFY ALL COMPONENTS

BASE KIT

Quantity included of each item is specific to ordered product configuration.

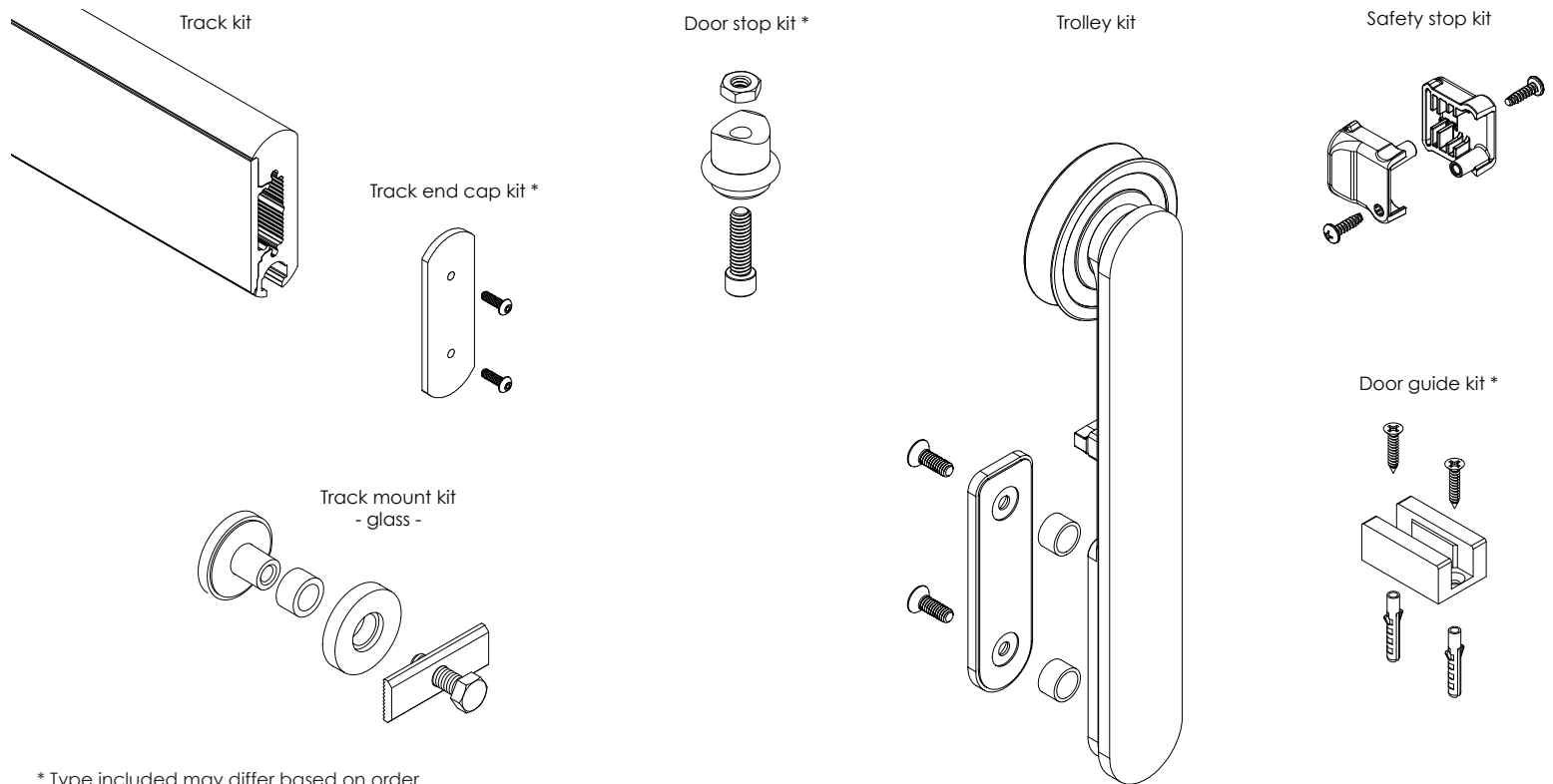

SYSTEM OPTIONS AND ADDITIONS

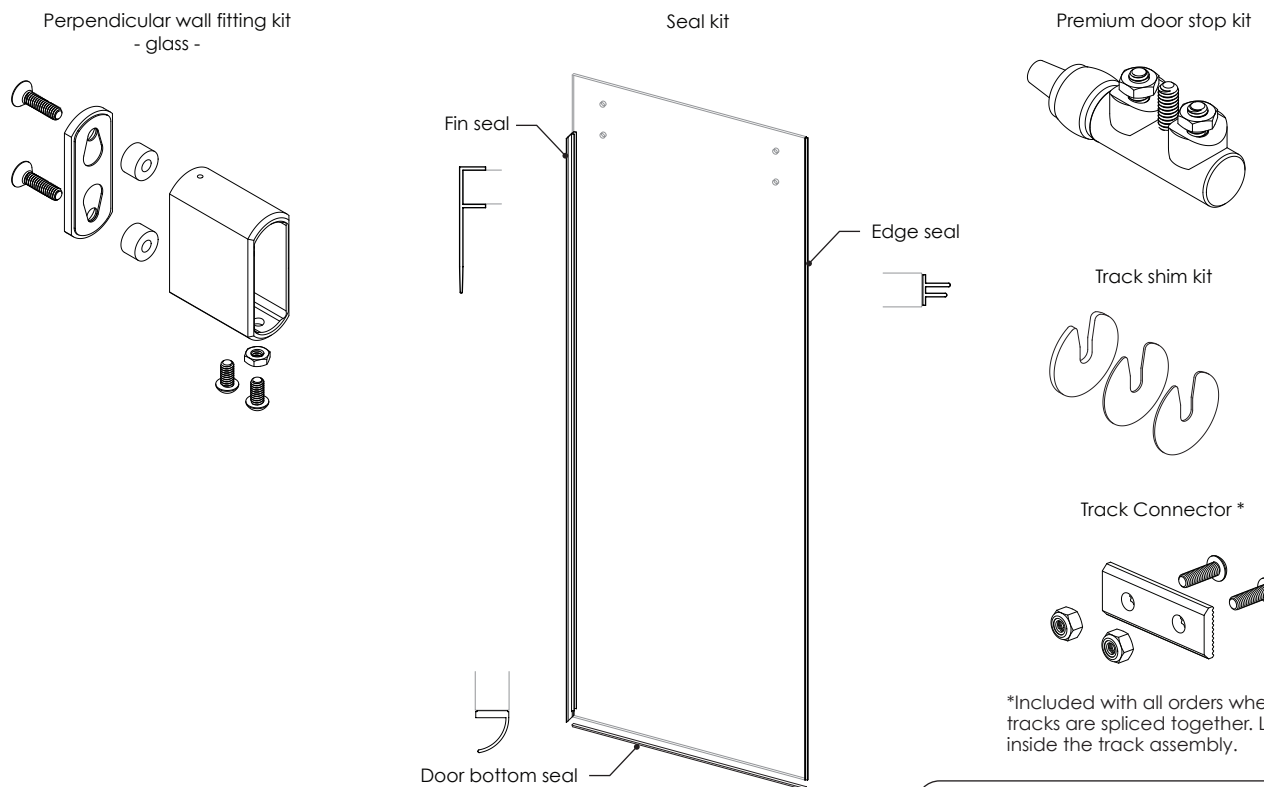

Go to www.krownlab.com for our complete product range.

3. REMOVE TRACK COVER

- ① Remove the track from the protective sleeve by gently prying the cover from the base with a slender plastic (non-marring) tool.
- ② If your order contains multiple tracks to be spliced together, remove the Track Connector located inside the track cavity.

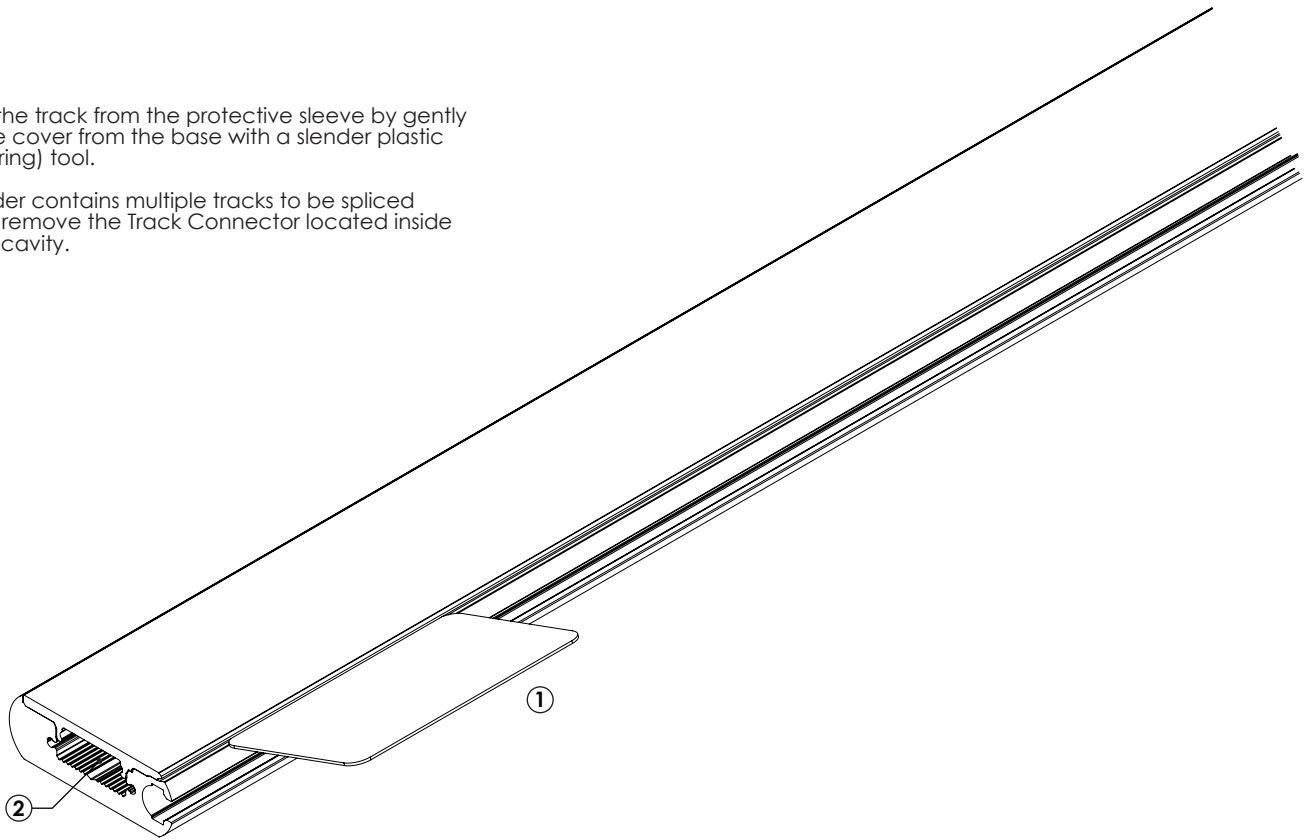

4. DETERMINE TRACK LOCATION ON WALL

Track location is determined by the site lite(s) and transom layout.

- ⚠ Ensure that all applicable Krownlab glass product specifications are adhered to, including but not limited to glass hole locations.
- ⚠ Krownlab hardware systems require that transom is a structural element able to support the weight of the door panel(s) as determined by a qualified professional.
- ⚠ Krownlab hardware systems are solely intended to support the door panel(s) and are NOT intended to structurally support transom or any other wall or partition member.
- ① Ensure that installation of side lite(s) and structural transom is complete before proceeding to the next step.

⚠ Krownlab's products are to be secured to structural elements able to support the weight of the door panel(s) and the dynamic forces of a sliding door system as determined by a qualified professional.

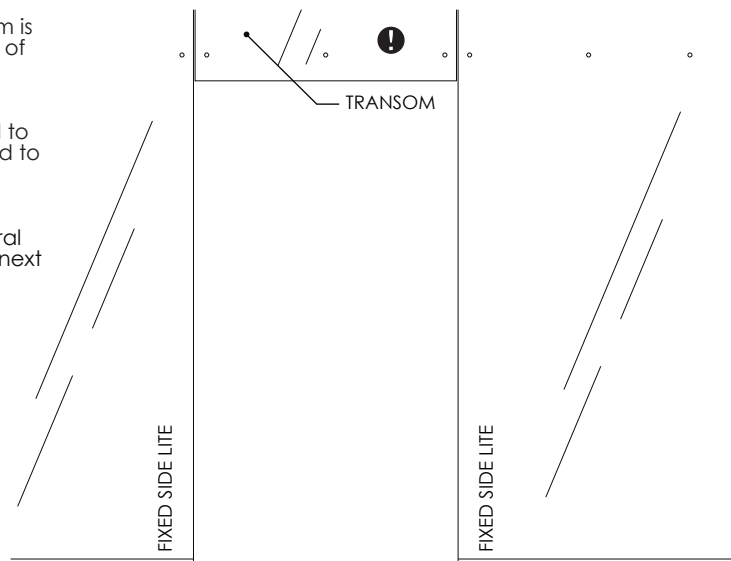

5. DETERMINE TRACK DRILL PATTERN

- ❗ Ensure that all applicable Krownlab glass product specifications are adhered to.
- ① If your track was ordered with mounting point holes drilled, skip to step 10.
- ② If your track was ordered undrilled, the track drill pattern is driven by the hole locations in your fixed side lite(s) and transom panels which are to be installed first.
- ❗ If your order contains multiple tracks to be spliced together, note that each individual track length is to follow the applicable drill pattern as outlined in your product's glass product specifications.

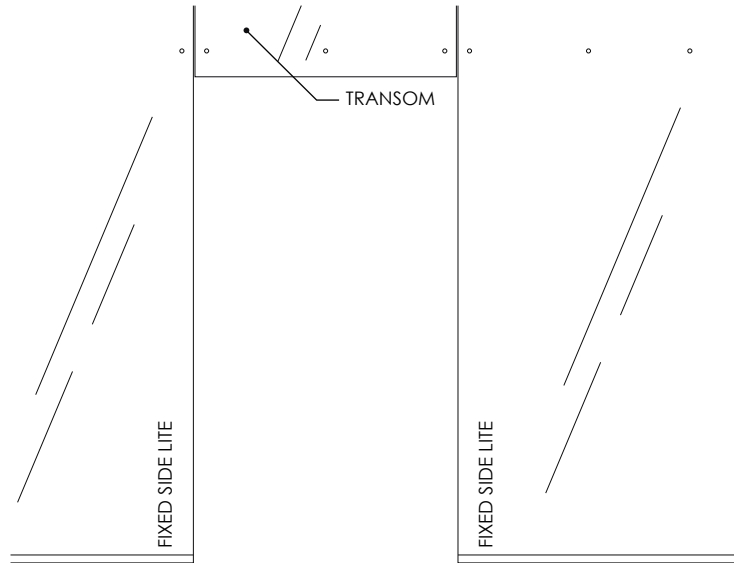

6. DETERMINE REQUIRED TRACK LENGTH

- ① Determine the desired open and closed positions of the door panel(s) considering door pulls and overlap region for the door guide.
- ② Calculate minimum required track length by determining system width for each door using the formula below:
SYSTEM WIDTH = (DOOR WIDTH x 2) - DOOR PANEL OVERLAP
- ❗ Minimum required track length can exceed system width as determined by side lite and transom hole locations.

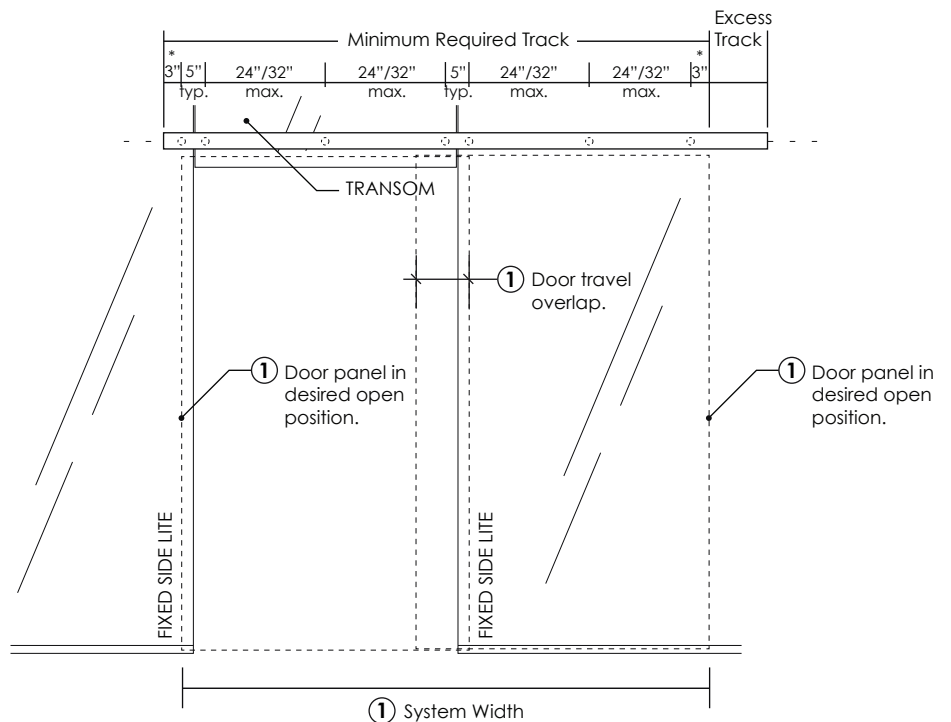

* Maximum length of load-bearing track allowed beyond end mounting points. Non load-bearing track surface has no required minimum.

7. SYSTEM OPTION - CUT TRACK TO LENGTH

To optionally trim excess track length prepare track(s) for cutting:

- ① Mark track cut location as determined using the System Width formula in the previous step.
- ⚠ For tracks mounting to wood studs, ensure that site specific stud locations are considered.
- ② Gently press to slide track springs clear of cut location.
- ③ Carefully reattach track cover to track base.
- ④ Align profile ends and tightly wrap the assembly with painters tape to prevent shift during cutting.
- ⑤ Cut track assembly using the appropriate tool and blade.
- ⚠ Cut in horizontal orientation with cover facing up.
- ⑥ Carefully remove tape and track cover from base.

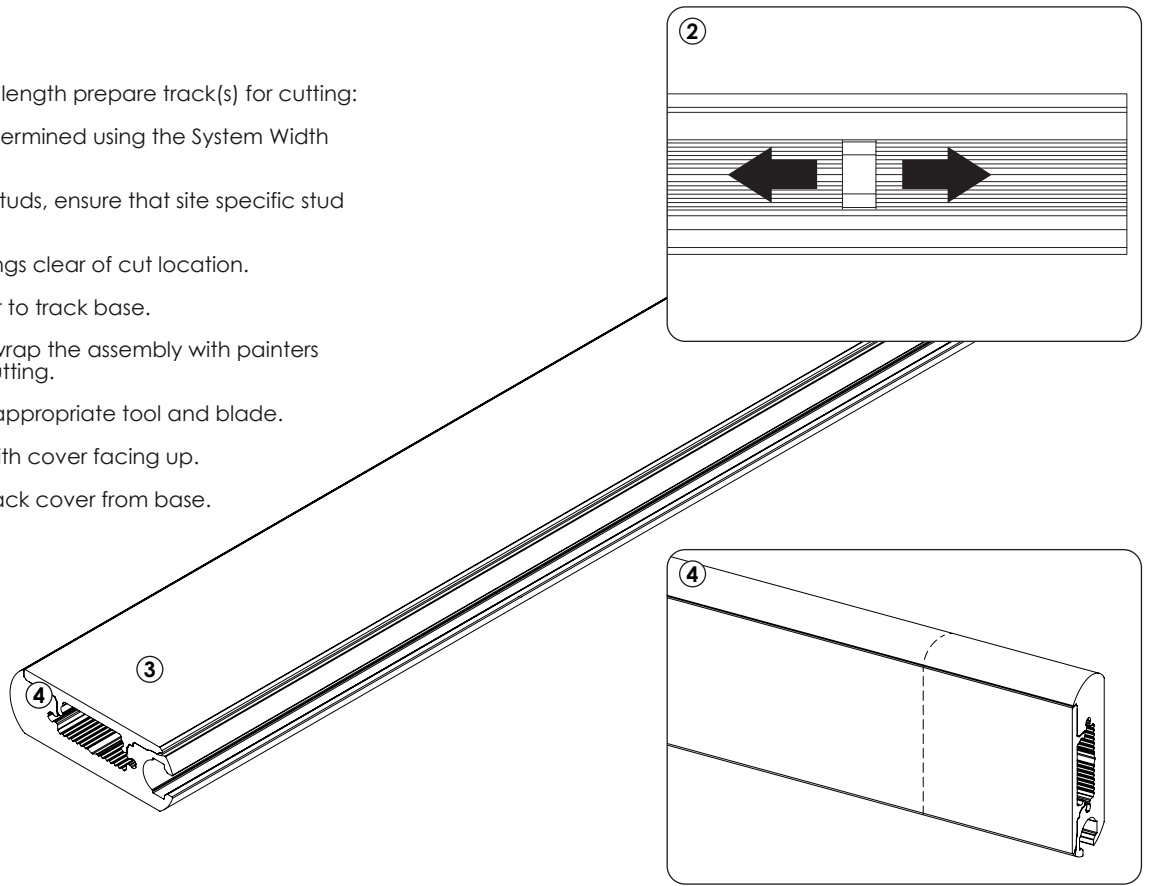

8. DRILL TRACK BASE

- ① With the appropriate lateral track wall position determined, apply the side lite and transom hole pattern to track base(s).
- ② Drill corresponding 9/16" holes along the centerline of the track base as shown.

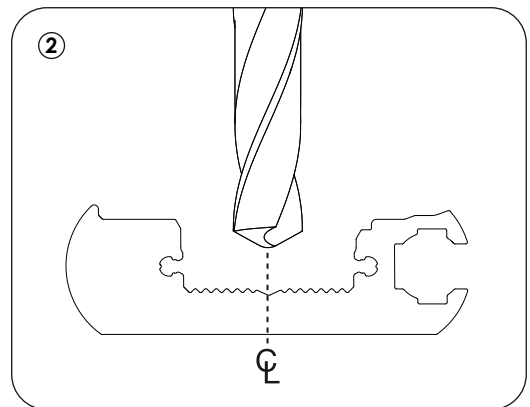
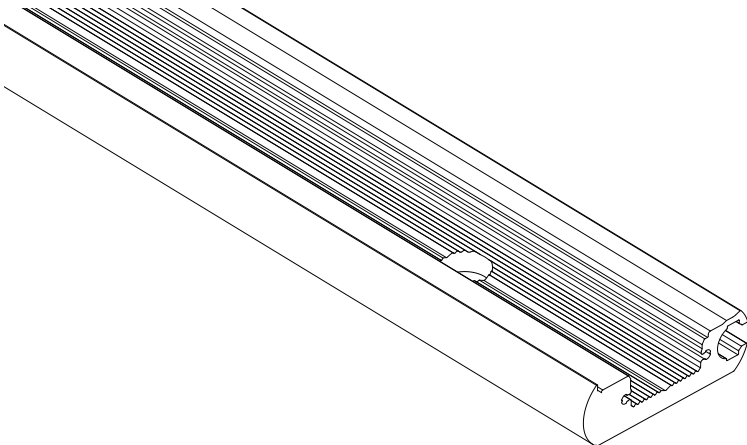

9. LOCATE TRACK MOUNTING POINTS ON WALL

Step not applicable.
Page intentionally left blank.
Proceed to next step.

10. CONNECT TRACK BASES

Installations with multiple adjoining tracks are required to be interlocked in order to provide a continuous weight bearing surface. Skip to the next step for single-track installations.

- 1 Butt track bases end-to-end ensuring that the colored sticker dot indicators are matching and face track connection point(s) as shown.
- 2 Using the track connector washer plate centered over the seam as a template, mark track bases for drilling.
- 3 Drill $13/64$ " holes in each track base.
- 4 Connect track bases by installing the track connector as shown. Ensure that washer plate teeth align with teeth in the track base before tightening.
- 5 Using a torque wrench, tighten fasteners to 48 inch-lbs (4 ft-lbs).

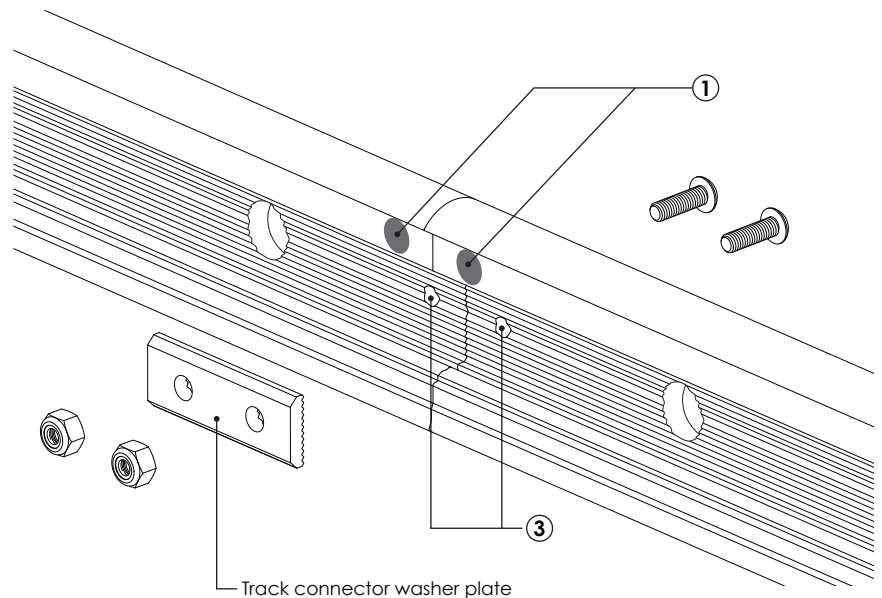
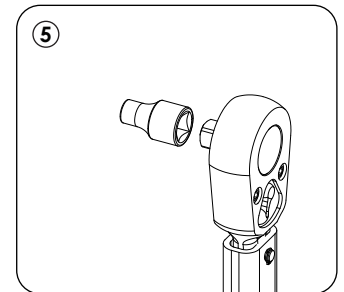

Track connectors are mandatory for all adjoining tracks in order to provide a continuous weight bearing surface.

11. INSTALL DRYWALL INSERTS

Step not applicable.
Page intentionally left blank.
Proceed to next step.

12. PILOT DRILL STRUCTURAL WALL

Step not applicable.
Page intentionally left blank.
Proceed to next step.





13. DETERMINE WALL CLEARANCE

Krownlab sliding hardware systems are compatible with 3/8" and 1/2" glass. Resulting door panel to wall clearance is compatible with standard glazing channels and other fixed glass fittings.

- ❗ Contact Krownlab Customer Support for atypical wall conditions that require wall clearance outside of the provided range.
- ❷ Identify the most appropriate track stand-off configuration using the formula and table below:

SYSTEM WALL CLEARANCE = DESIRED DOOR PANEL CLEARANCE + DOOR PANEL THICKNESS

- ❗ 3/8" minimum recommended door panel to wall surface clearance.
- ❗ Track stand-offs included dependant upon order configuration. See table below.

TRACK MOUNT STAND-OFF CONFIGURATIONS			
			
RESULTING SYSTEM WALL CLEARANCES			
1"	1-1/4"	1-1/2"	1-3/4"
TRACK MOUNT KIT(S) REQUIRED			
A	A + B	A + B	A

A = Standard track mount kit
 B = Track mount reduction kit

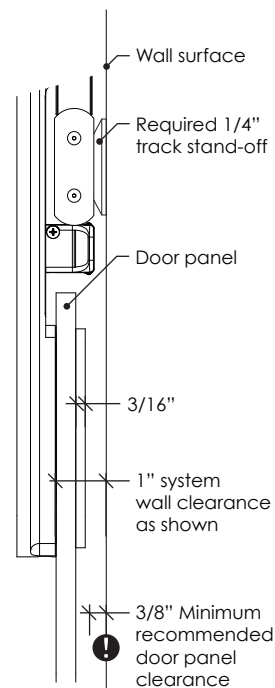

14. INSTALL DOOR STOPS

- ❶ Slide one door stop into each end of the track base. Do not yet tighten fasteners.
- ❗ If installing Premium Door Stops, reference applicable installation instructions in parallel.

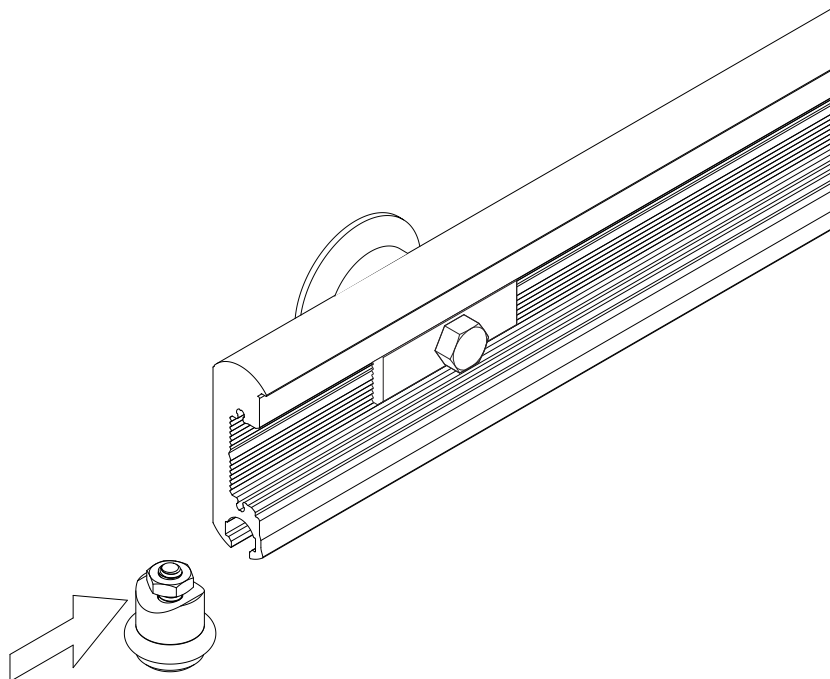
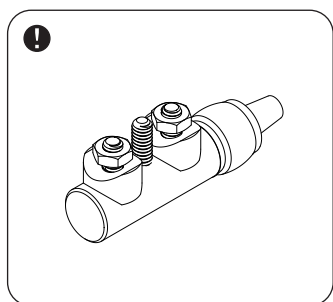

15. SYSTEM OPTION - INSTALL PERPENDICULAR WALL FITTING

If your order includes perpendicular wall fittings, reference applicable separate installation instructions in parallel to install the fitting.

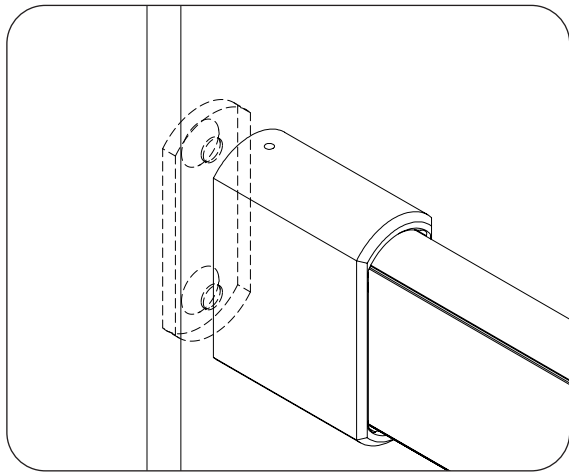

16. INSTALL END CAPS

- ⚠ End cap assembly may vary at each end of track base.
- ① Select the scenario(s) below that matches your track configuration:
 - No perpendicular wall fittings: Follow step 2 below for each track base end.
 - Perpendicular wall fitting on one end: Follow step 2 below for the opposite end.
 - Perpendicular wall fittings on both ends: The track was completed in previous steps.
 - Connecting multiple tracks together: Follow step 2 below on the outside ends of connected track run.
- ② Gently secure the end cap(s) to track base.
- ⚠ Do not over-tighten!

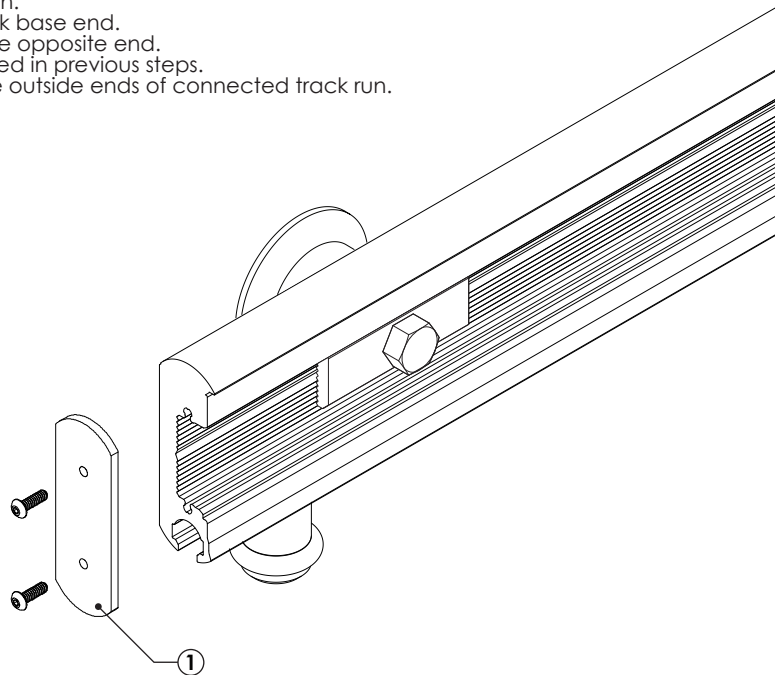

17. MOUNT TRACK BASE TO WALL

- ① If needed, gently press to slide track springs to be 1" away from holes to prevent clamping a spring under track washer plate. Evenly space springs along the length of track to ensure track cover is well-retained.
- ② With the door stops face down, loosely install one end of your track with the correct length mounting fastener based on glass thickness.
- ⚠ Track glass nuts come assembled with gaskets and bushings. Both must be used at each mounting point.
- ③ Repeat with the opposite end of the track.
- ⚠ Support the track assembly along its length if multiple tracks are linked together.
- ④ Loosely install the remaining mounting points.

Side lite Thickness	Length
3/8"	7/8"
1/2"	1"

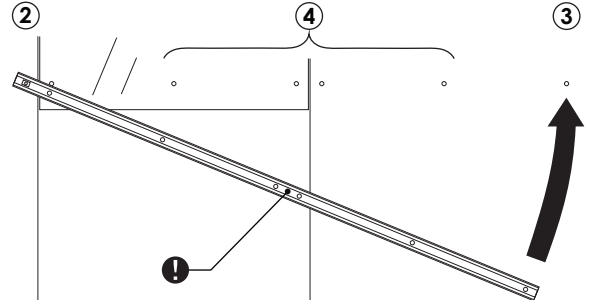
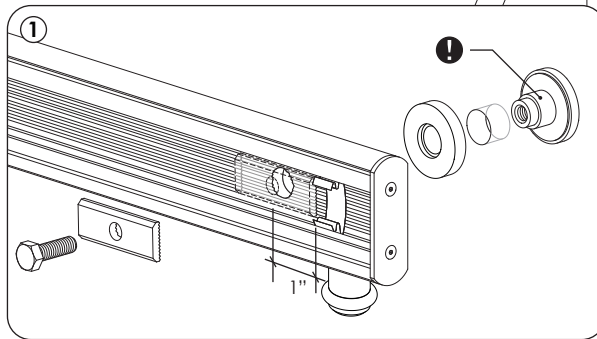
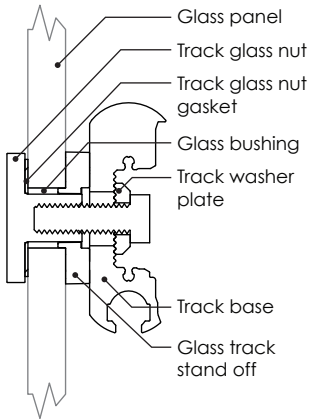

⚠ Krownlab's products are to be secured to structural elements able to support the weight of the door panel(s) and the dynamic forces of a sliding door system as determined by a qualified professional.

18. LEVEL AND ADJUST TRACK HEIGHT

- ① Snug, but don't yet tighten each track fastener starting at the center and moving toward the ends. For maximum adjustment, start by positioning the washer plate in the center (neutral) position.
- ⚠ Be sure to account for sloped or uneven floor when determining final desired track height.
- ② Using a level, adjust the position of the washer plate at each mounting point until track is level. If desired, adjust overall track height.
- ⚠ Ensure that washer teeth align with teeth in the track base before tightening fasteners.
- ③ Using a torque wrench, tighten fasteners to 120 inch-lbs (10 ft-lbs).
- ⚠ Do not over-tighten to deform track washer plates.

⚠ Installation on a vertical surface is required in order to ensure track base is installed plumb.

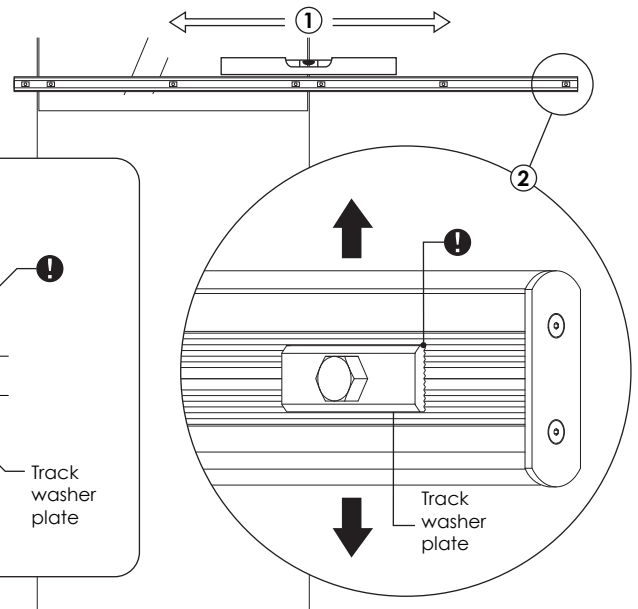
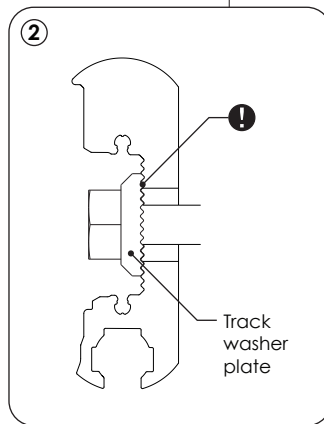
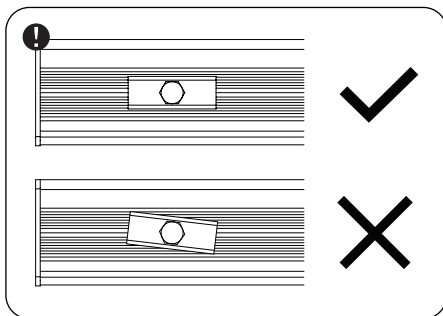
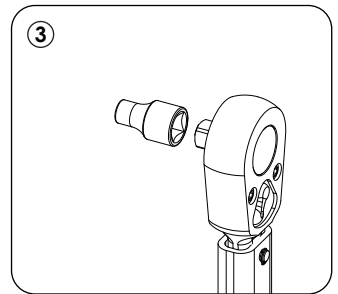

19. SYSTEM OPTION - INSTALL TRACK SHIMS

- ① Sight down the length of your track to determine if unevenness in the wall surface is causing your track to bow. Skip to the next step if track base is straight.
- ② If out of true, loosen select track attachment points as needed and insert shims from below as shown. Ensure that the opening of the shim faces up. Start with one of the thinner shims, adding and swapping shims as needed until the track is straight along entire length to within the thickness of one shim.
- ⚠ Never use more than one shim kit at any mounting point. Track shims may only be used at mounting points that pull the track out of true.

NOTE: Bowing in the track will negatively affect the system performance, causing increased friction and excessive wear. Krownlab's warranty does not cover wear caused by improper installation.

- ③ Retighten track fasteners to provided specifications.



Do not use shims for the purpose to extend the track standoff distance.

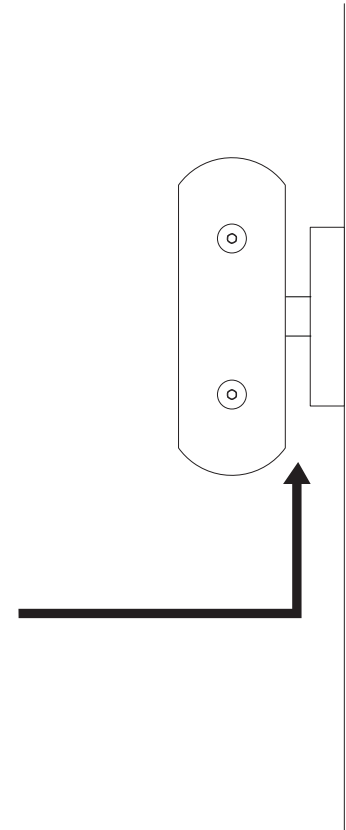
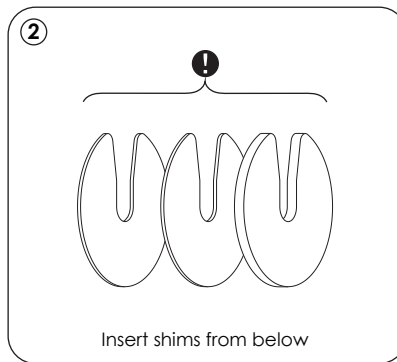

20. SECURE TRACK COVER

- ① Confirm that track base is level, straight, and that all mounting points have been securely fastened.
- ② Inspect each track spring to ensure no interference with the mounting hardware and that they are evenly spaced along the length of the track base.
- ⚠ For installations with multiple connected tracks, ensure that the colored sticker dot indicators on inside of track cover are matching track base color and face track connection point(s).
- ⚠ Ensure that the arrow on the inside of the track cover is facing up.
- ③ Carefully reattach track cover(s) to track base(s) confirming fully seated and securely attached along the entire length. Adjust track spring locations if needed.

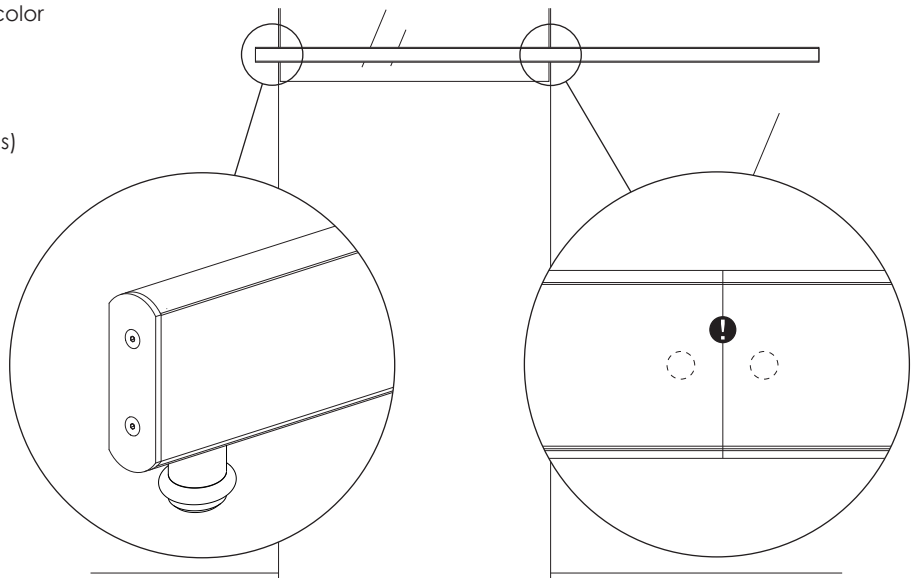
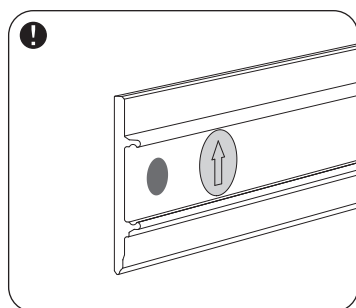

21. PREPARE DOOR PANEL FOR DOOR GUIDE

Step not applicable.
Page intentionally left blank.
Proceed to next step.

22. PREPARE DOOR PANEL FOR TROLLEYS

- ❗ Ensure that glass door panel(s) conform to Krownlab's glass product specifications.
- ① Confirm hole placement, sizing, and overall preparation per Krownlab's glass panel specifications.
- ② Inspect glass for any defects, including but not limited to chips, deformations, and irregularly shaped holes.

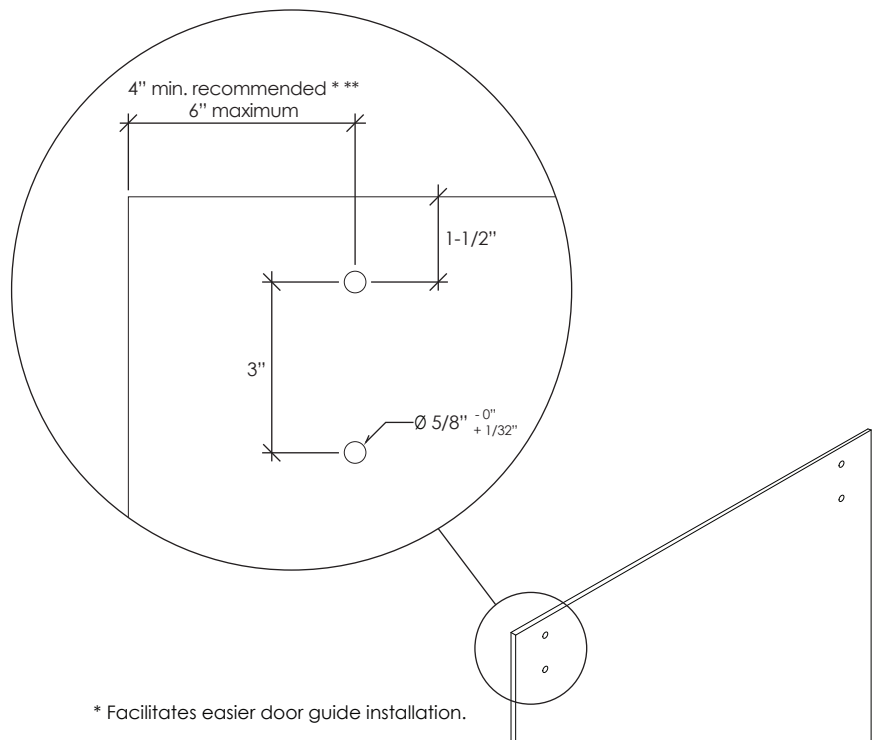

Do not install defective glass. Any glass defect is a safety hazard and requires replacement prior to installation.

23. ATTACH TROLLEYS TO DOOR PANEL

- ① Install the trolleys onto the door panel(s) using the provided fasteners.
- ② Gently tighten, then back out each screw a half turn. This will allow door panel height adjustment in the next step.
- ③ Carefully hang your door panel(s).

Do not yet install your door pulls or other door hardware.

- ❗ Included glass bushings must be used in all installations.

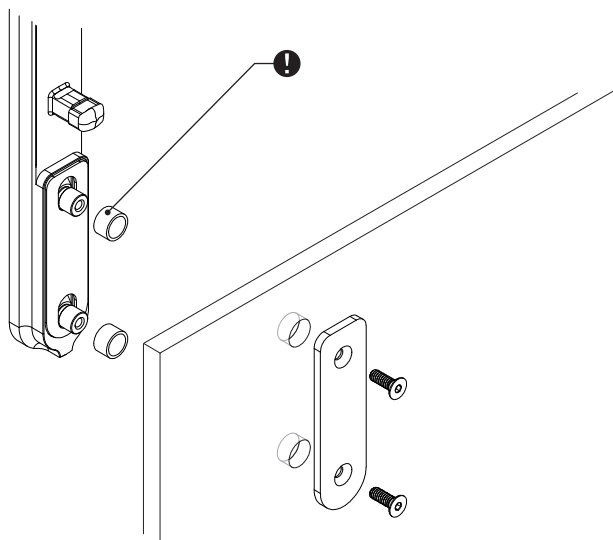

24. ADJUST DOOR PANEL HEIGHT

- ① Check door panel floor clearance along full length of door travel, taking door guide into consideration. Reference step 26.
 - ② If necessary, alter the height of the door panel by adjusting the set screws at the bottom of each trolley using an Allen wrench.
- ❗ Do not tighten set screw.
- ③ If needed, door panel can be further adjusted in height by raising or lowering track assembly. Unhang door panel(s), remove track cover, and see step 18.
 - ④ After the door panel height is defined, tighten the trolley screws on the backside of the door panel(s) using a torque wrench, and torque to 108 inch-lbs (9 ft-lbs).

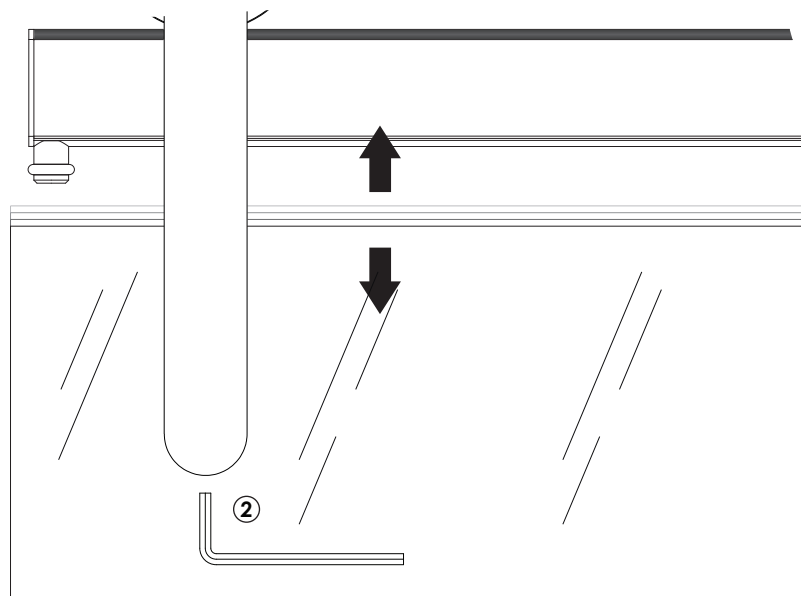
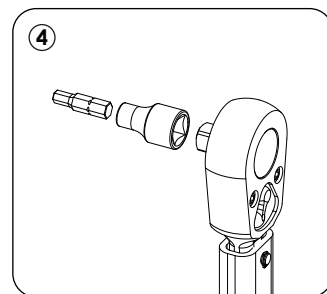

25. INSTALL SAFETY STOPS

If installing Premium Door Stops, reference those installation instructions in parallel.

- 1 Remove protective cap from trolley post.
- 2 For **Standard Door Stop** installation, place curved safety stops towards door stops, and flat safety stops away from door stops as shown. For **Premium Door Stop** installation, reference separately provided installation instructions.
- 3 Ensure the first safety stop is fully seated and properly aligned so that half of the trolley post is completely covered by the safety stop.
- 3 Slide the second safety stop over the other side of the post.
- 4 Ensure that both safety stops are aligned and fully seated.
- 4 Thread provided screws into both sides of the safety stops using a #2 Phillips Screw Driver and lightly tighten.
- 5 Repeat above steps for second trolley with reverse safety stop positions.

NOTE: Keep the protective caps and reuse when removing and rehang door panel to prevent damage to the track.

! Not correctly installing safety stops can result in the door panel derailing during normal use which can cause damage and a safety hazard.

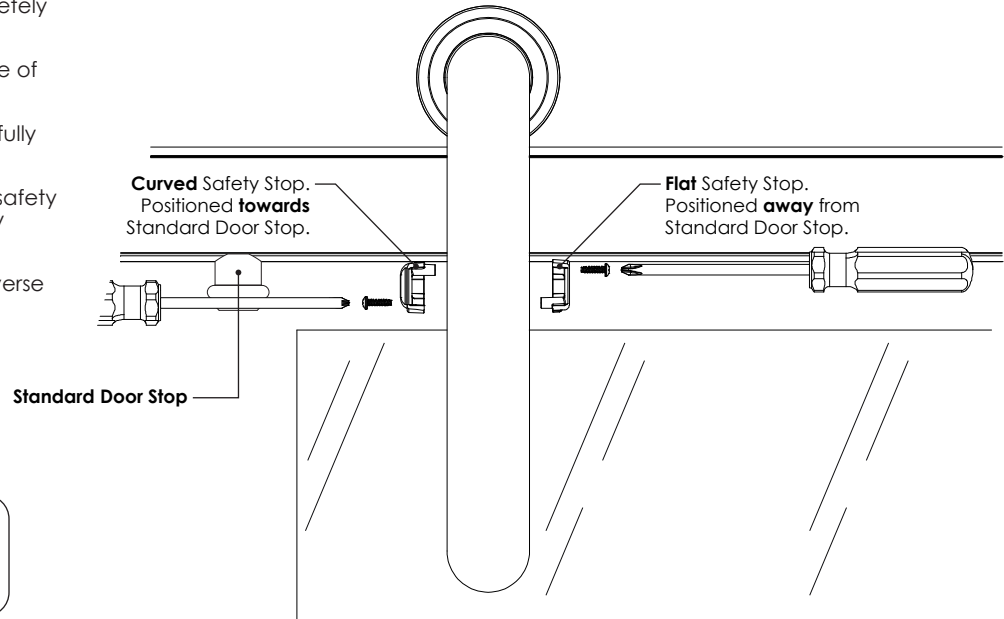
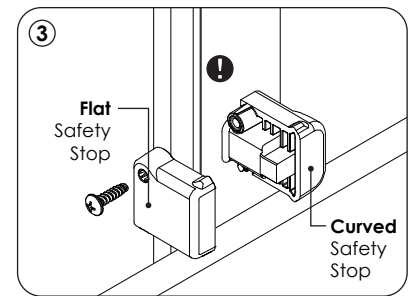

26. INSTALL DOOR GUIDE

Refer to the separate installation instructions for the door guide that is included with your order*. Once installed, continue to next step.

*Included door guide may vary from examples shown below.

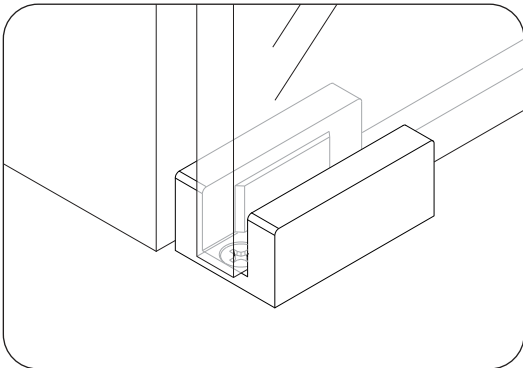

! Installation of a door guide is required and must for safety be engaged along the full length of door travel.

27. INSTALL DOOR PULLS

- 1 If applicable, install door pulls following applicable installation instructions.

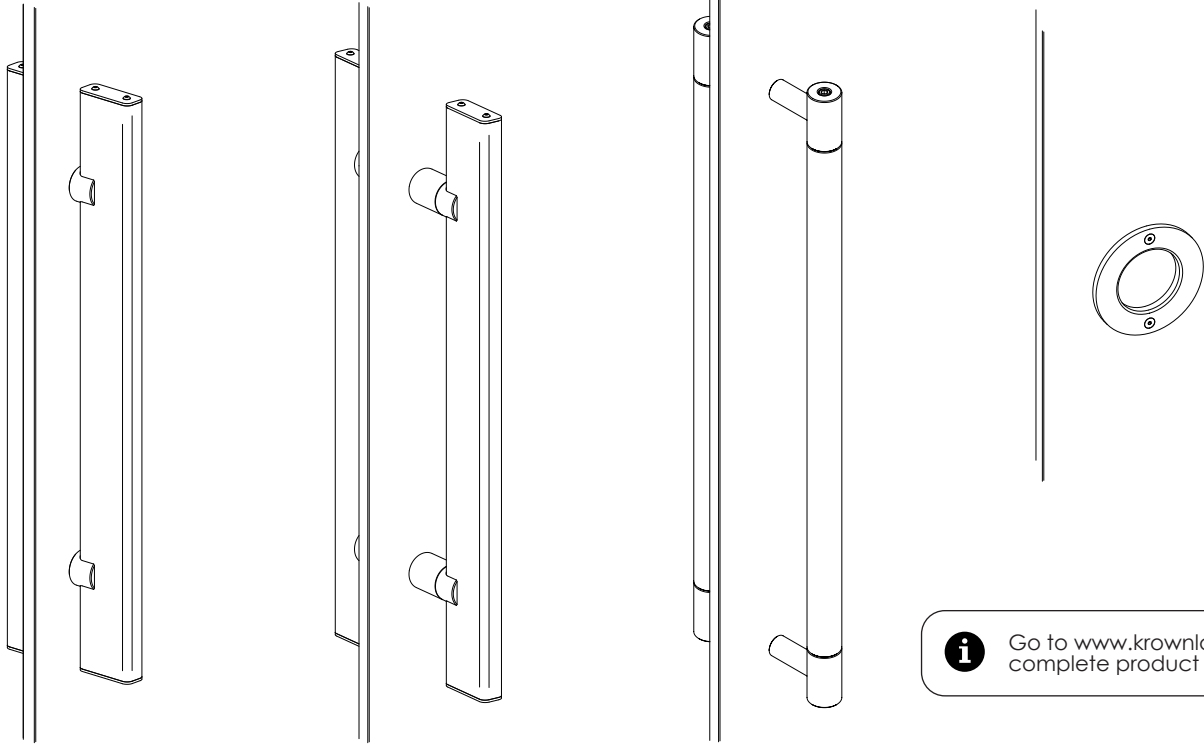

i Go to www.krownlab.com for our complete product range.

28. SET DOOR TRAVEL

If installing Premium Door Stops, reference those installation instructions in parallel.

- 1 With the door in the desired open position, slide the door stop until it touches the safety stop of the nearby trolley.
- 2 Repeat with the door in the closed position, sliding the door stop until it touches the safety stop of the nearby trolley.
- 3 Tighten all door stop fasteners in place by hand.
- 4 Confirm that door stop locations have not shifted while tightening. Readjust if needed.
- 5 Using a torque wrench, tighten fasteners to 110 inch-lbs (9.5 ft-lbs).

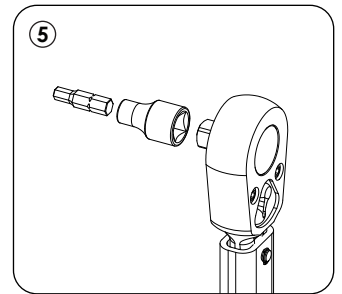

! Not tightening door stops to provided specs can cause the door to slide off the end of the track and cause damage and a safety hazard.

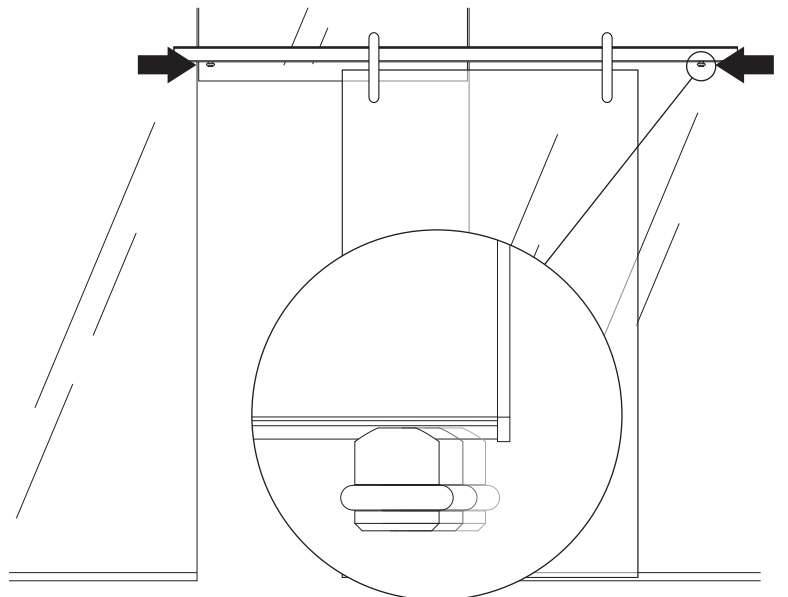

29. CARE AND MAINTENANCE

- ❗ Krownlab products require routine care and maintenance. Read and understand these requirements in our Product Care & Maintenance guide.
- ① Thoroughly clean product and remove all debris and fingerprints immediately after installation as described in our Product Care & Maintenance guide.
- ② Enjoy your new exceptional Krownlab Sliding Door System.



Not properly following Krownlab's Care & Maintenance guide can cause excessive wear and degrade product performance over time.

Visual product representations herein may differ from the actual products. Components and details are subject to improvement changes.

© 2023 Krownlab. All Rights Reserved. Krownlab and the Krownlab logo is registered Trademark of Krown Lab, Inc.
