

DOCUMENT:	PRODUCT SPECIFICATIONS	DOOR APPLICATION:	SINGLE, BI-PARTING, BYPASSING	DRAWING SCALE:	3/4" = 1'-0" (1:16)	KROWNLAB 2351 NW York St. Portland, OR 97210 +1 503 292 6998 www.krownlab.com support@krownlab.com
SYSTEM:	ODEN	PANEL THICKNESS:	1-3/8" MINIMUM	UNITS:	INCHES	
MOUNTING STYLE:	TOP MOUNT	MAXIMUM WEIGHT:	UP TO 400LBS (CONTACT US FOR HEAVIER PANELS)	DATE:	4/11/2018	

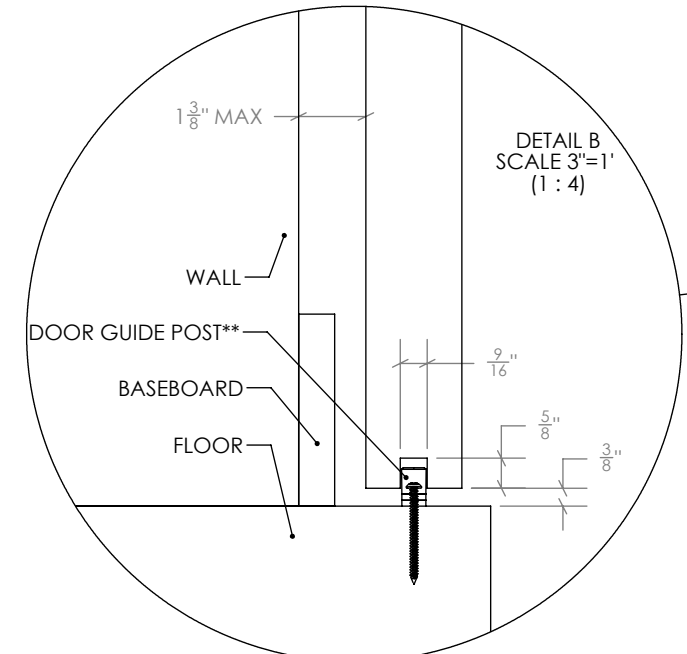
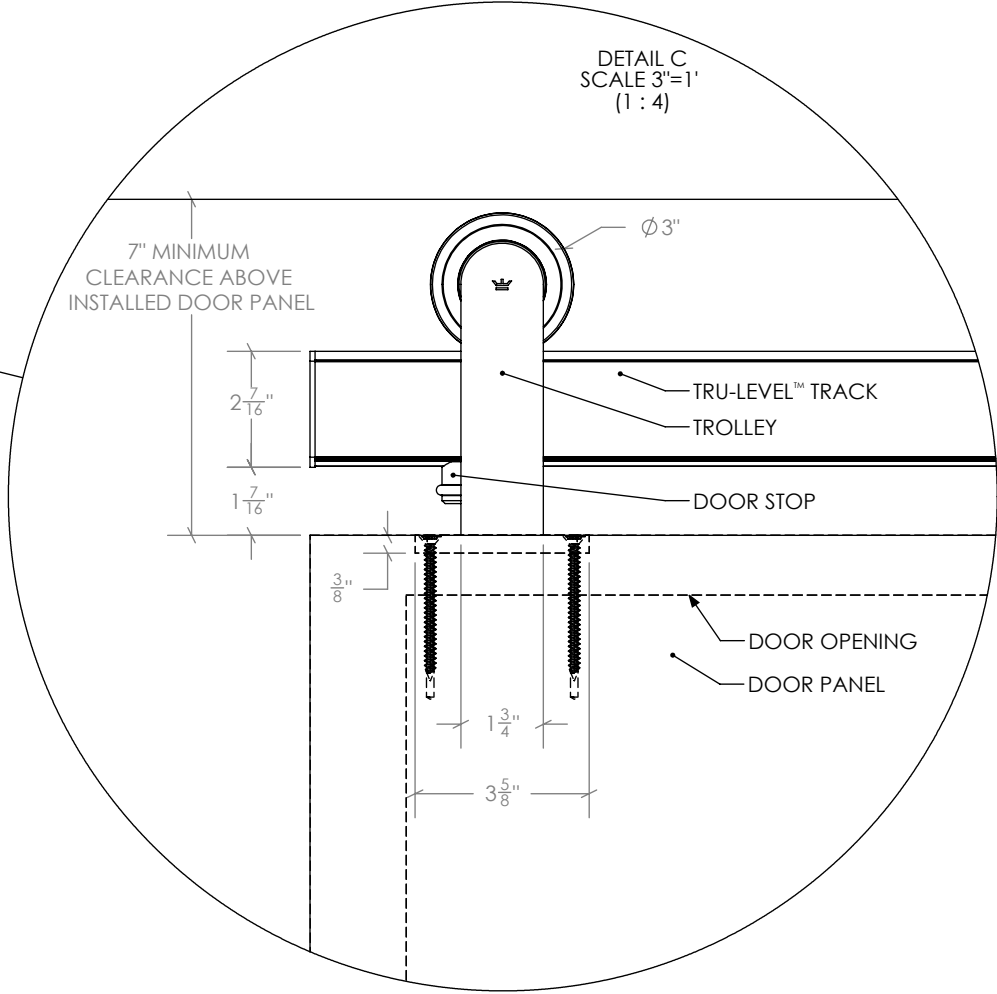
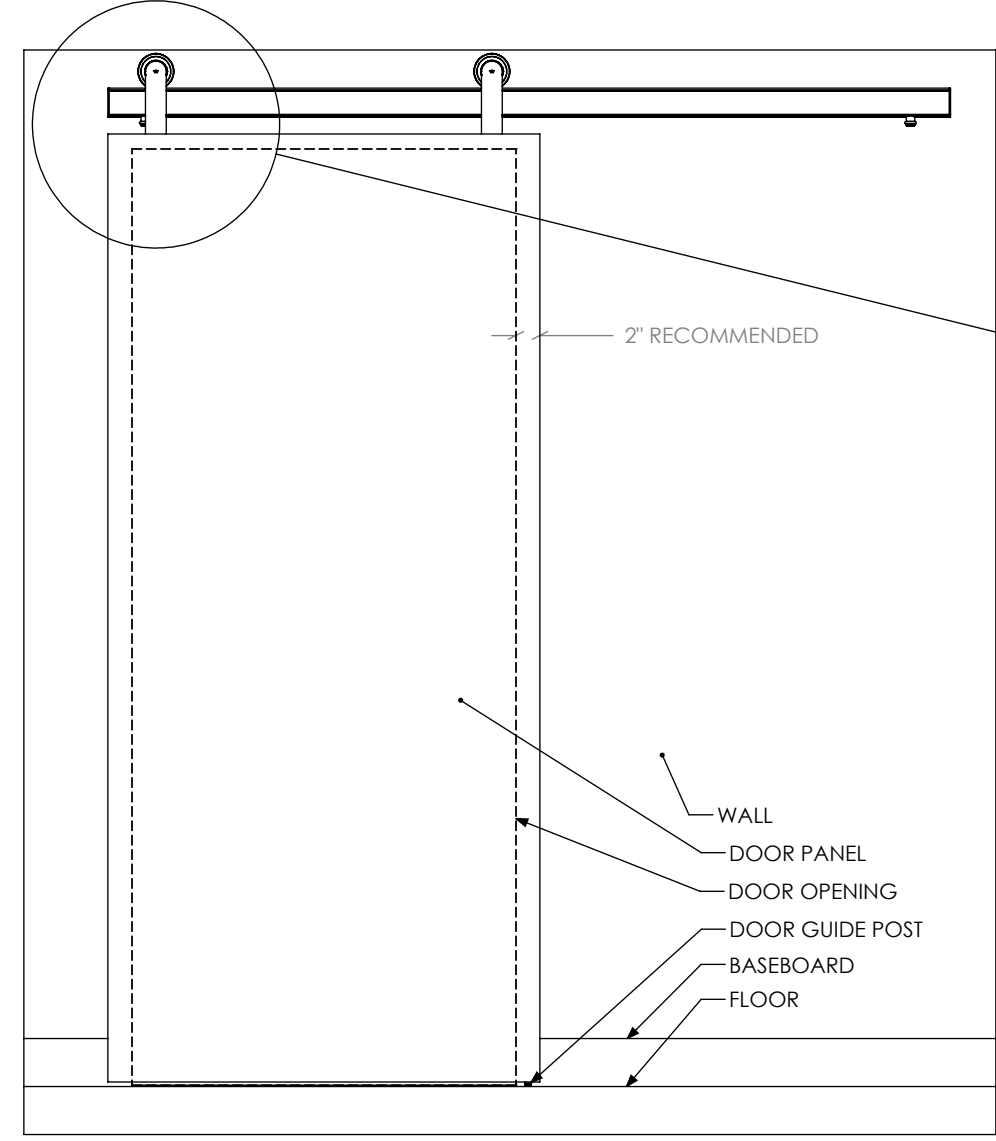
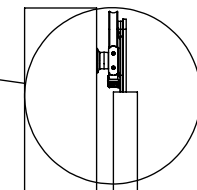
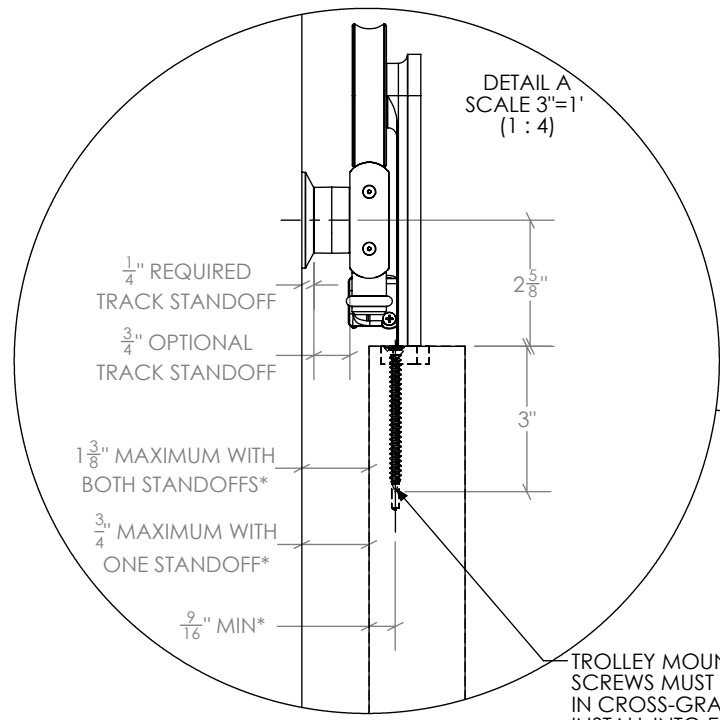

* = THESE LIMITS VARY WITH WOOD SPECIES.

** = DOOR GUIDE MAY DIFFER

DOCUMENT:	PRODUCT SPECIFICATIONS	DOOR APPLICATION:	SINGLE, BI-PARTING, BYPASSING	DRAWING SCALE:	3/4" = 1'-0" (1:16)	KROWNLAB 2351 NW York St. Portland, OR 97210 +1 503 292 6998 www.krownlab.com support@krownlab.com
SYSTEM:	ODEN	PANEL THICKNESS:	3/4" TO 2-1/2"* (CHOOSE TOP MOUNT FOR THICKER PANELS)	UNITS:	INCHES	
MOUNTING STYLE:	FACE MOUNT	MAXIMUM WEIGHT:	UP TO 400LBS (CONTACT US FOR HEAVIER PANELS)	DATE:	4/11/2018	



* = 2-1/2" PANEL WILL HAVE 1/8" WALL CLEARANCE.

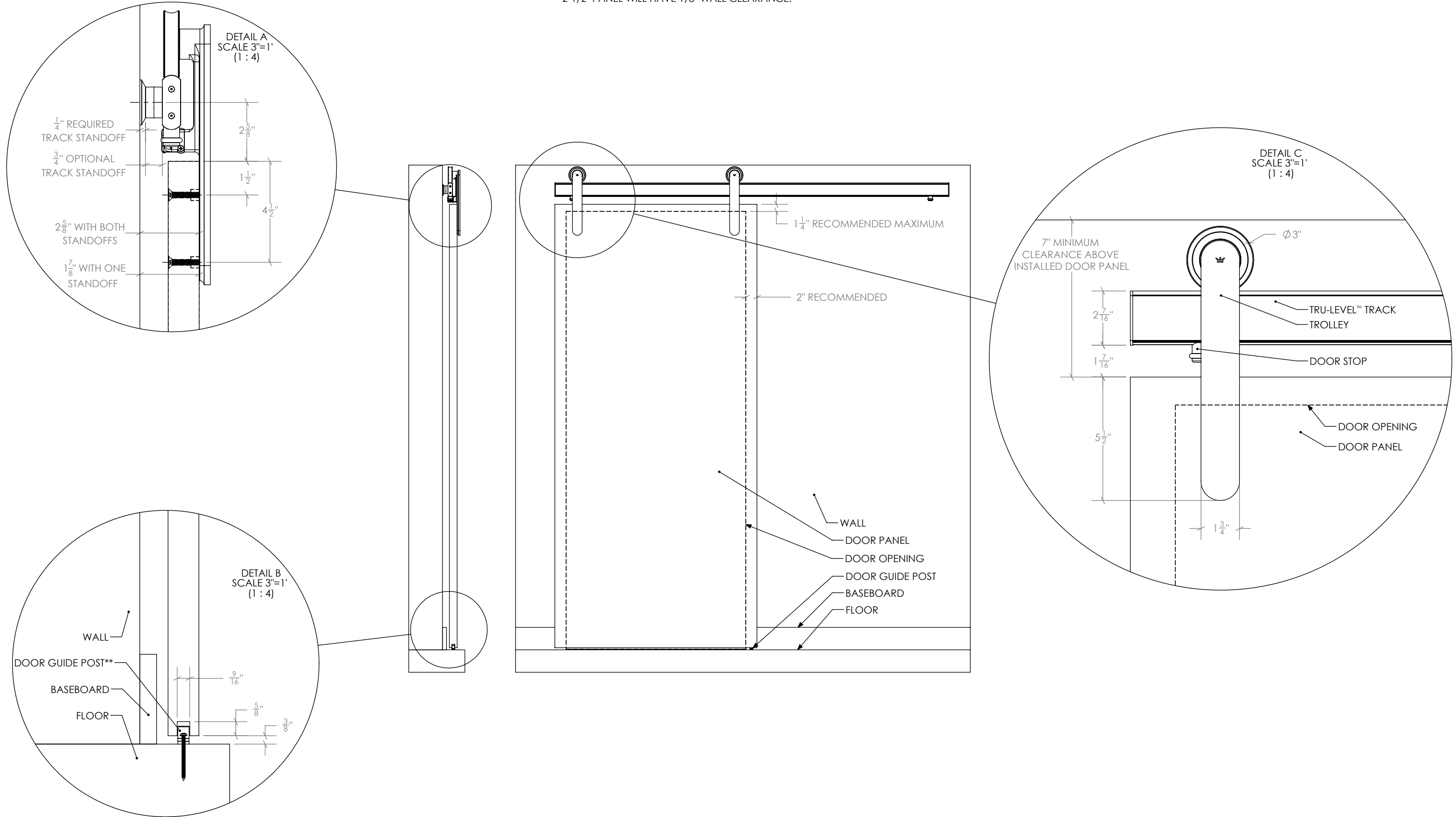

** = DOOR GUIDE MAY DIFFER

DOCUMENT: PRODUCT SPECIFICATIONS	DOOR APPLICATION: SINGLE, BI-PARTING, BYPASSING	DRAWING SCALE: 3/4" = 1'-0" (1:16)	KROWNLAB 2351 NW York St. Portland, OR 97210 +1 503 292 6998 www.krownlab.com support@krownlab.com
SYSTEM: ODEN	PANEL THICKNESS: 3/8" TO 1/2" (CONTACT US FOR PANELS OUTSIDE OF THIS RANGE)	UNITS: INCHES	
MOUNTING STYLE: GLASS MOUNT	MAXIMUM WEIGHT: UP TO 400LBS (CONTACT US FOR HEAVIER PANELS)	DATE: 4/11/2018	

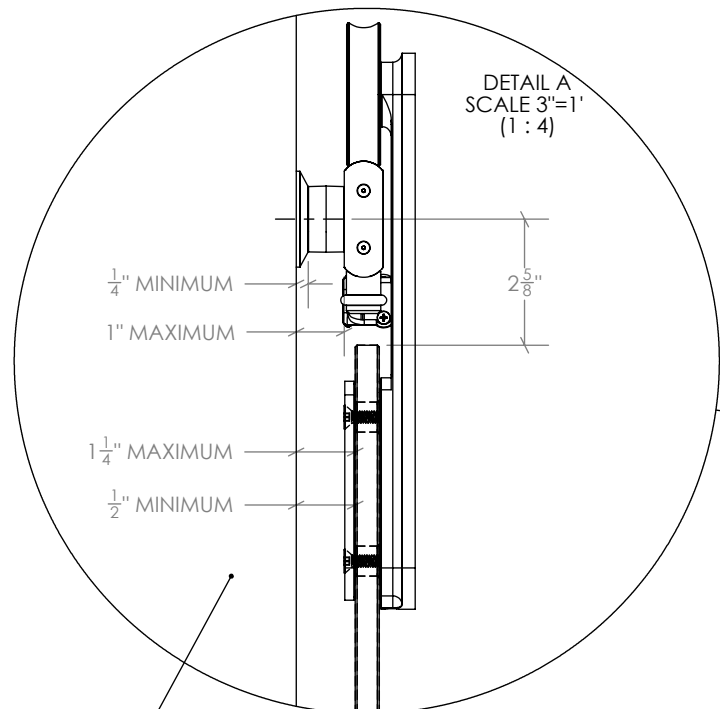

GENERIC WALL SHOWN. TRU-LEVEL TRACK DRAWINGS IN FOLLOWING PAGES WILL COVER FRAMED AND GLASS WALL TYPES.

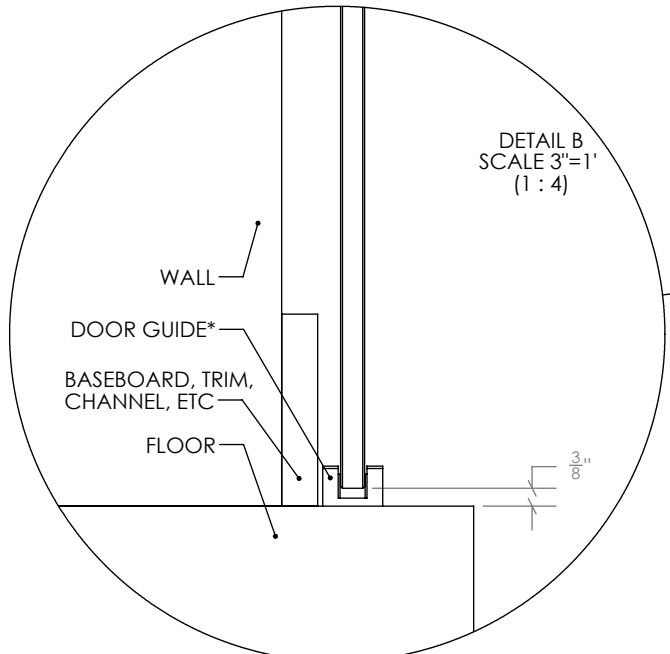
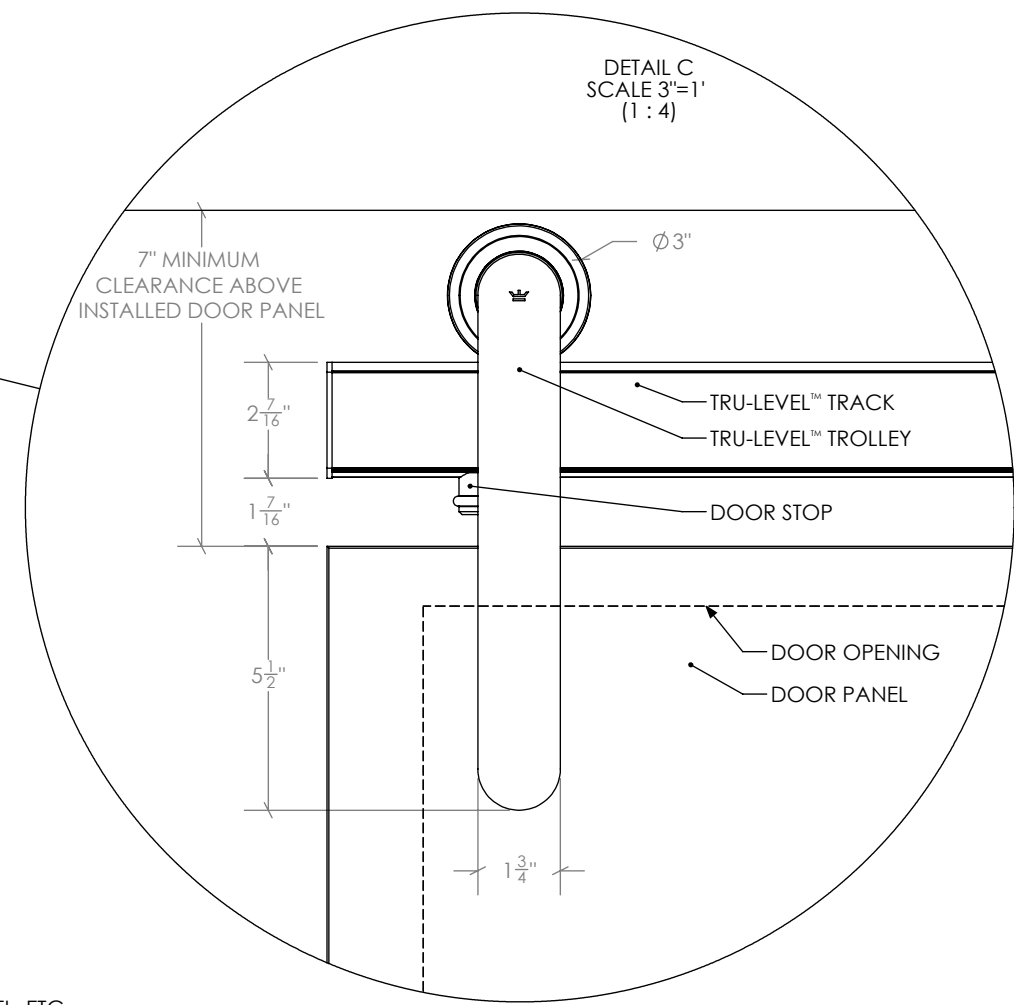
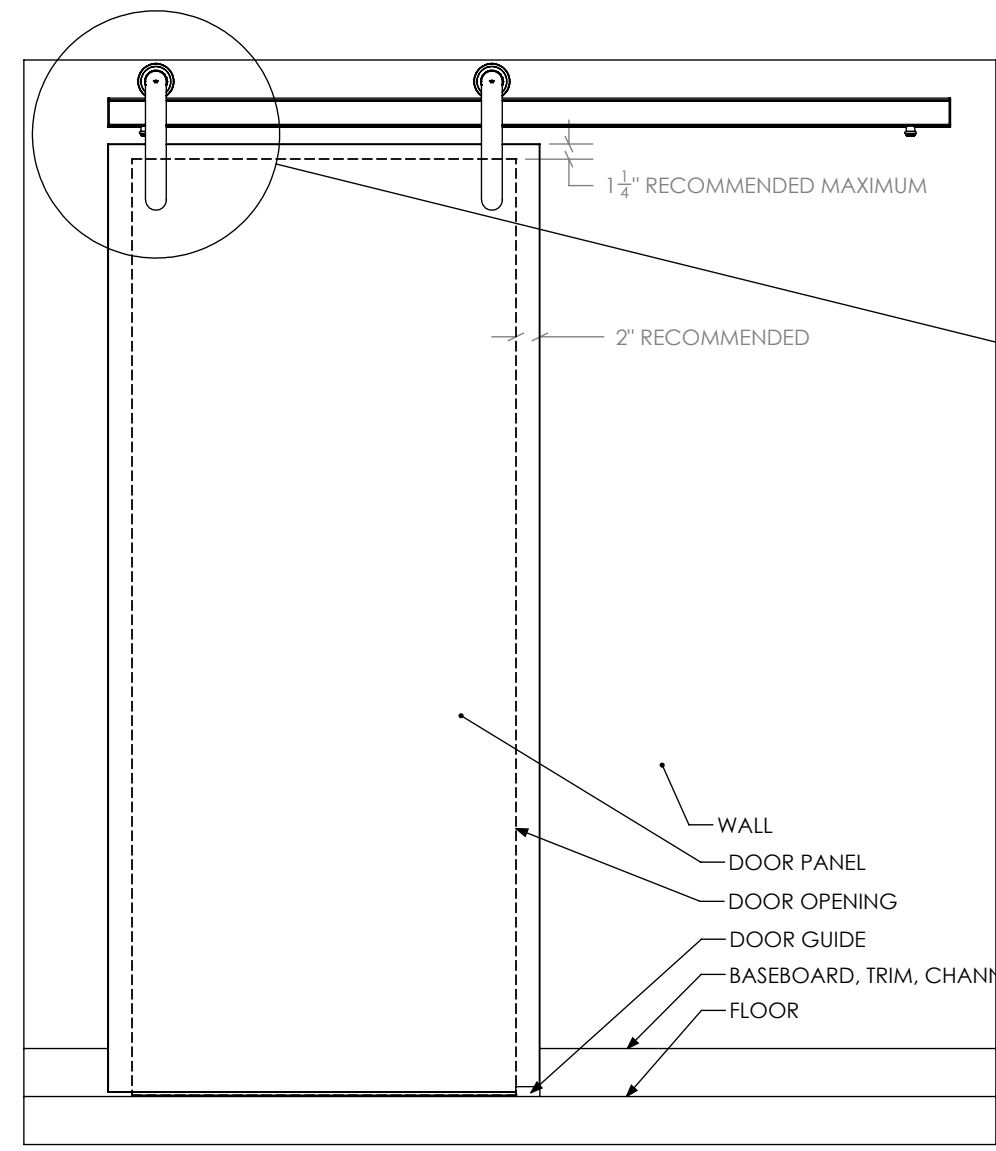
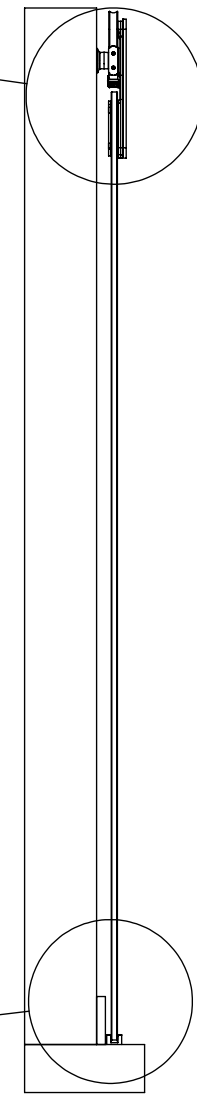

* = DOOR GUIDE MAY DIFFER

DOCUMENT:	PRODUCT SPECIFICATIONS	DOOR APPLICATION:	SINGLE, BI-PARTING, BYPASSING	DRAWING SCALE:	4" = 1'-0" (1:3)	KROWNLAB 2351 NW York St. Portland, OR 97210 +1 503 292 6998 www.krownlab.com support@krownlab.com
SYSTEM:	ODEN	PANEL THICKNESS:	1-3/8" MINIMUM	UNITS:	INCHES	
MOUNTING STYLE:	TOP MOUNT	MAXIMUM WEIGHT:	UP TO 400LBS (CONTACT US FOR HEAVIER PANELS)	DATE:	4/11/2018	



WHAT'S INCLUDED:
 2 x - #A204 - ODEN TOP MOUNT TROLLEY KIT
 1 x - #A020 - DOOR GUIDE POST KIT (DOOR GUIDE MAY DIFFER - MULTIPLE OPTIONS EXIST)
 1 x - #Txxxx - TRU-LEVEL™ TRACK SYSTEM WITH ALL MOUNTING HARDWARE (SEE SEPARATE PAGE)

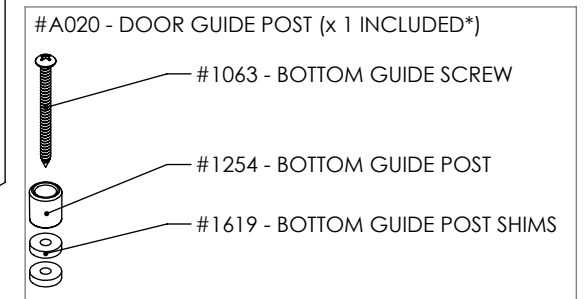
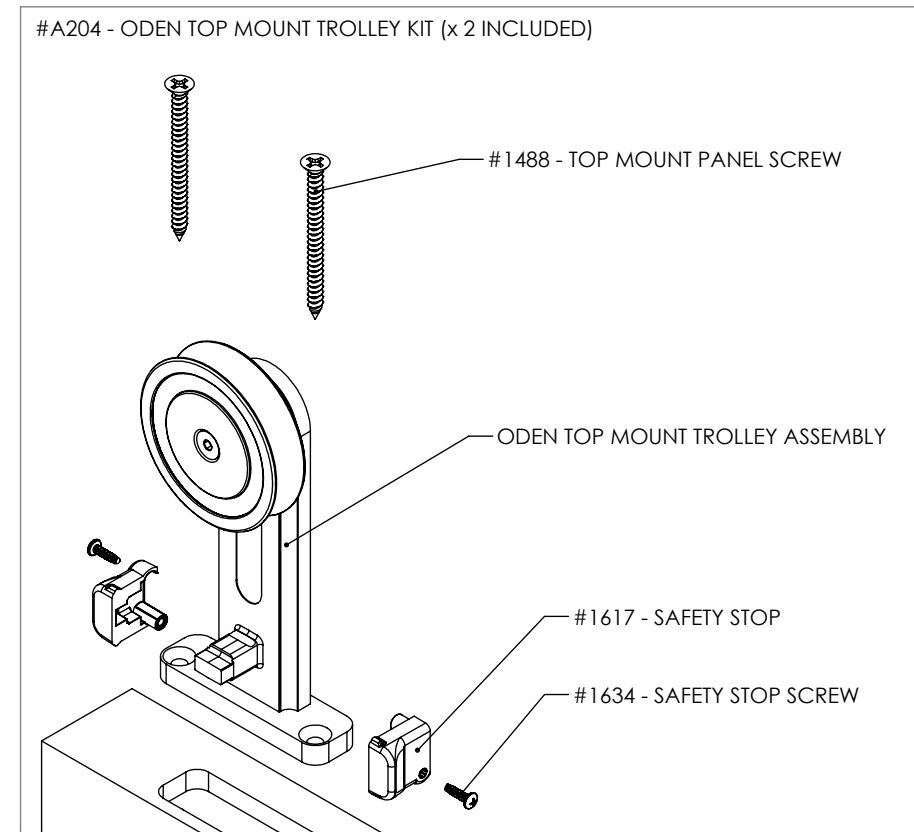
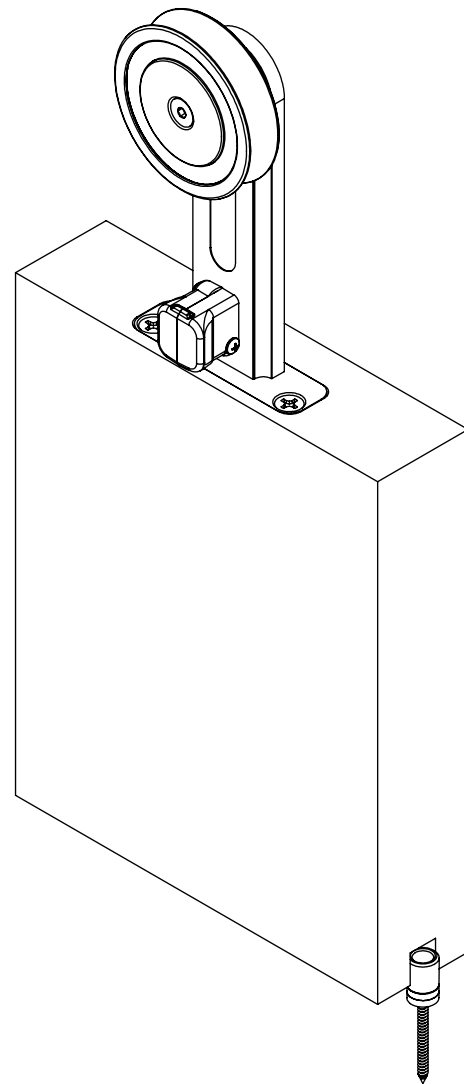
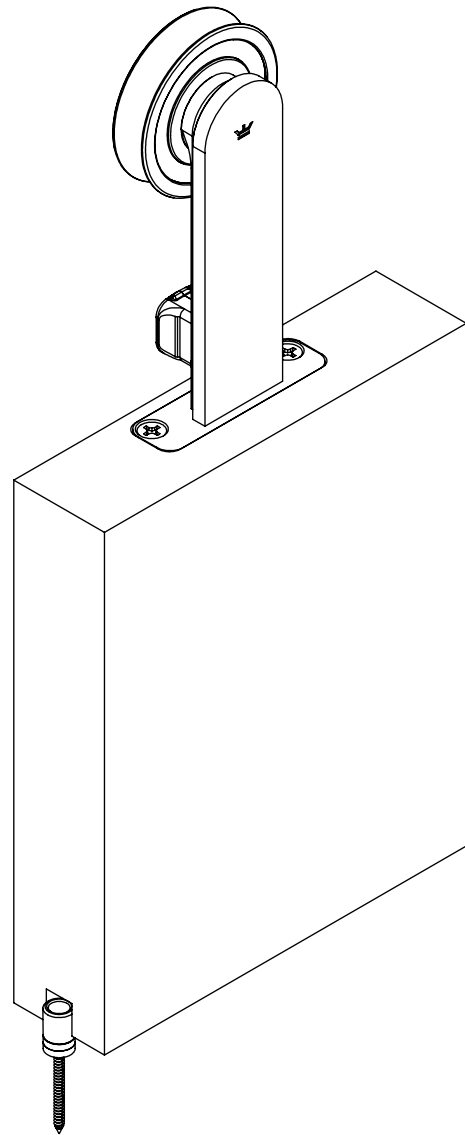

* = THE DOOR GUIDE MAY DIFFER - MULTIPLE OPTIONS EXIST

DOCUMENT:	PRODUCT SPECIFICATIONS	DOOR APPLICATION:	SINGLE, BI-PARTING, BYPASSING	DRAWING SCALE:	4" = 1'-0" (1:3)	KROWNLAB 2351 NW York St. Portland, OR 97210 +1 503 292 6998 www.krownlab.com support@krownlab.com	
SYSTEM:	ODEN	PANEL THICKNESS:	3/4" TO 2-1/2"* (CHOOSE TOP MOUNT FOR THICKER PANELS)	UNITS:	INCHES		
MOUNTING STYLE:	FACE MOUNT	MAXIMUM WEIGHT:	UP TO 400LBS (CONTACT US FOR HEAVIER PANELS)	DATE:	4/11/2018		

* = 2-1/2" PANEL WILL HAVE 1/8" WALL CLEARANCE.

WHAT'S INCLUDED:
 2 x - #A205 - ODEN FACE MOUNT TROLLEY KIT
 1 x - #A020 - DOOR GUIDE POST KIT (DOOR GUIDE MAY DIFFER - MULTIPLE OPTIONS EXIST)
 1 x - #Txxxx - TRU-LEVEL™ TRACK SYSTEM WITH ALL MOUNTING HARDWARE (SEE SEPARATE PAGE)

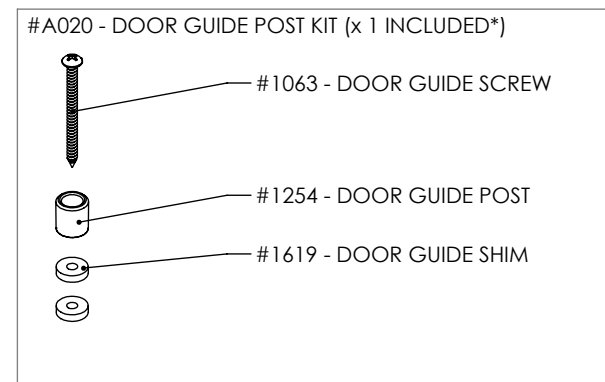
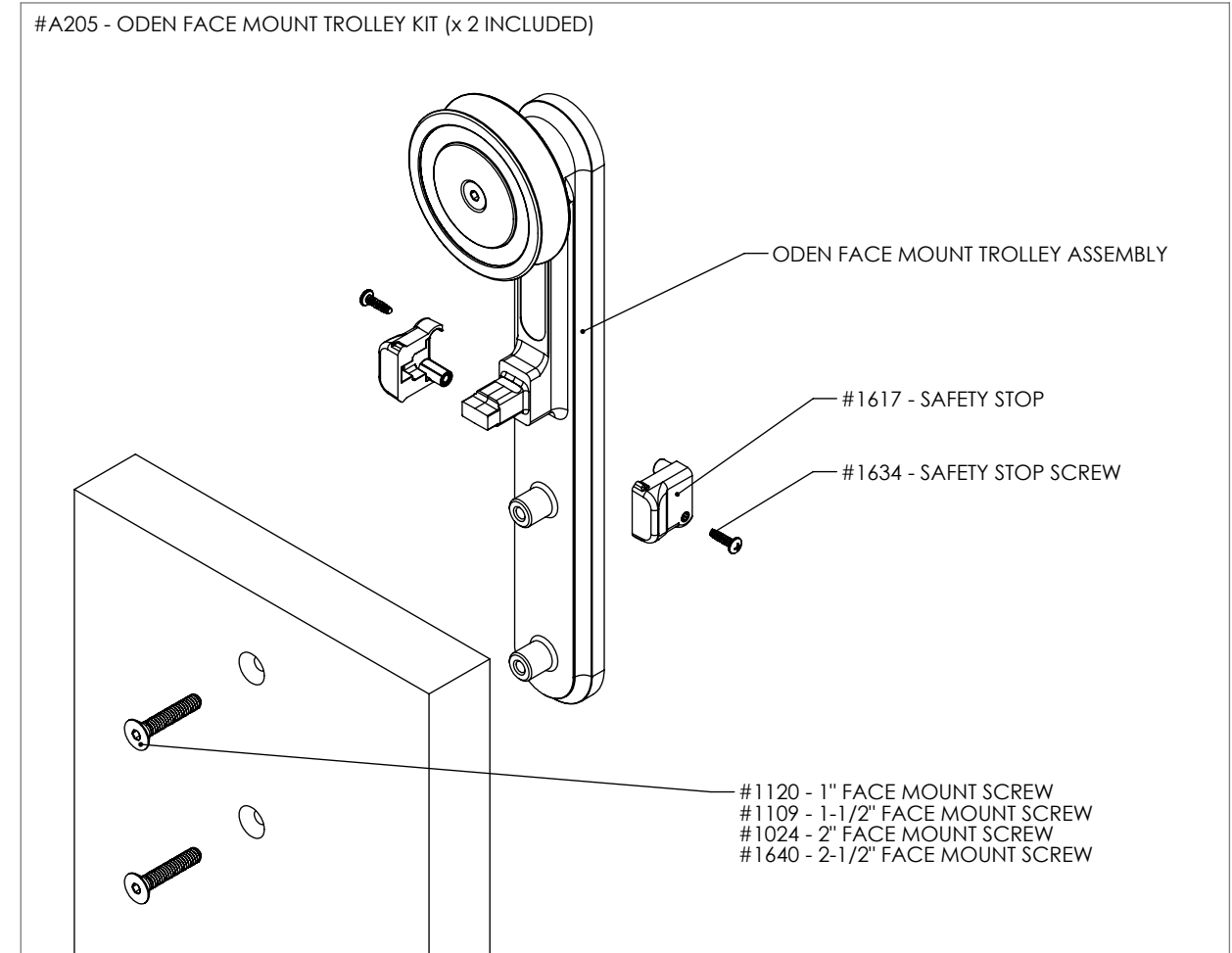
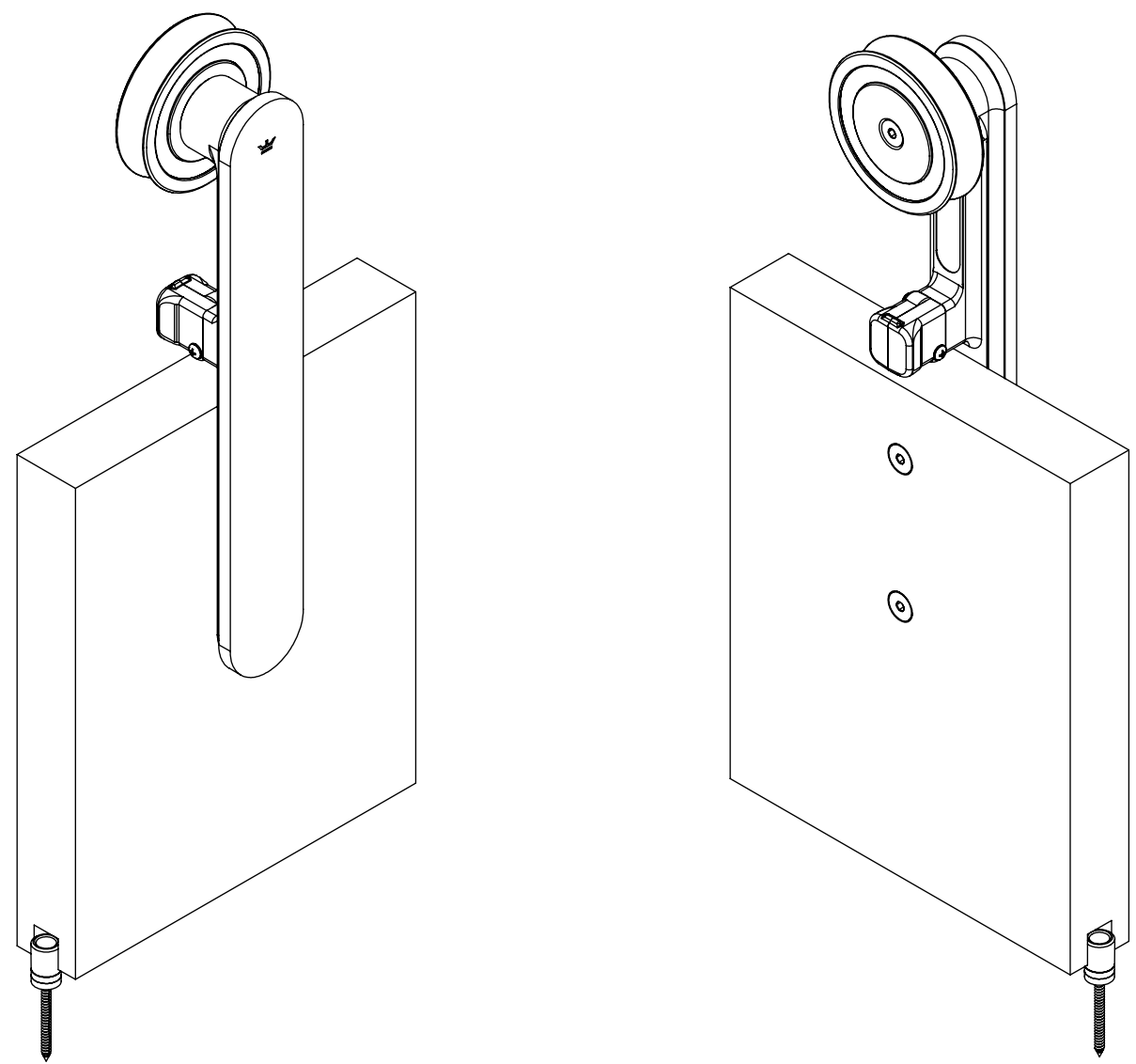

* = THE DOOR GUIDE MAY DIFFER - MULTIPLE OPTIONS EXIST

DOCUMENT:	PRODUCT SPECIFICATIONS	DOOR APPLICATION:	SINGLE, BI-PARTING, BYPASSING	DRAWING SCALE:	4" = 1'-0" (1:3)	KROWNLAB 2351 NW York St. Portland, OR 97210 +1 503 292 6998 www.krownlab.com support@krownlab.com
SYSTEM:	ODEN	PANEL THICKNESS:	3/8" TO 1/2" (CONTACT US FOR PANELS OUTSIDE OF THIS RANGE)	UNITS:	INCHES	
MOUNTING STYLE:	GLASS MOUNT	MAXIMUM WEIGHT:	UP TO 400LBS (CONTACT US FOR HEAVIER PANELS)	DATE:	4/11/2018	



WHAT'S INCLUDED:
 2 x - #A206 - ODEN GLASS MOUNT TROLLEY KIT
 1 x - #A219 - DOOR GUIDE KIT (DOOR GUIDE MAY DIFFER - MULTIPLE OPTIONS EXIST)
 1 x - #Txxxx - TRU-LEVEL™ TRACK SYSTEM WITH ALL MOUNTING HARDWARE (SEE SEPARATE PAGE)

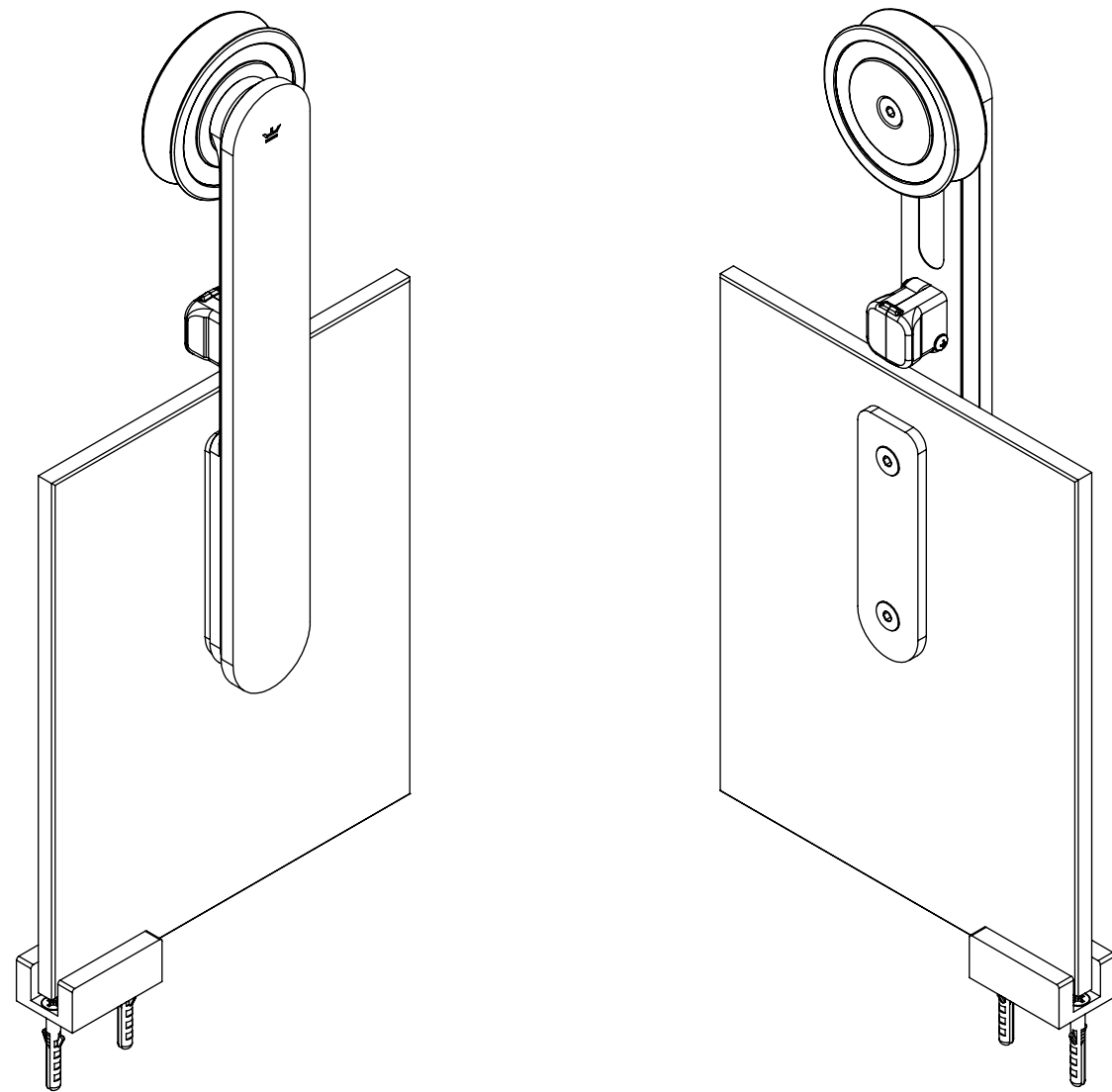

#A206 - ODEN GLASS MOUNT TROLLEY KIT (x 2 INCLUDED)

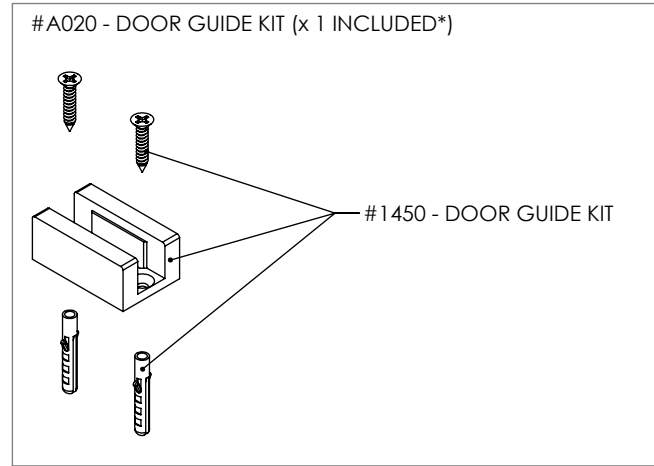
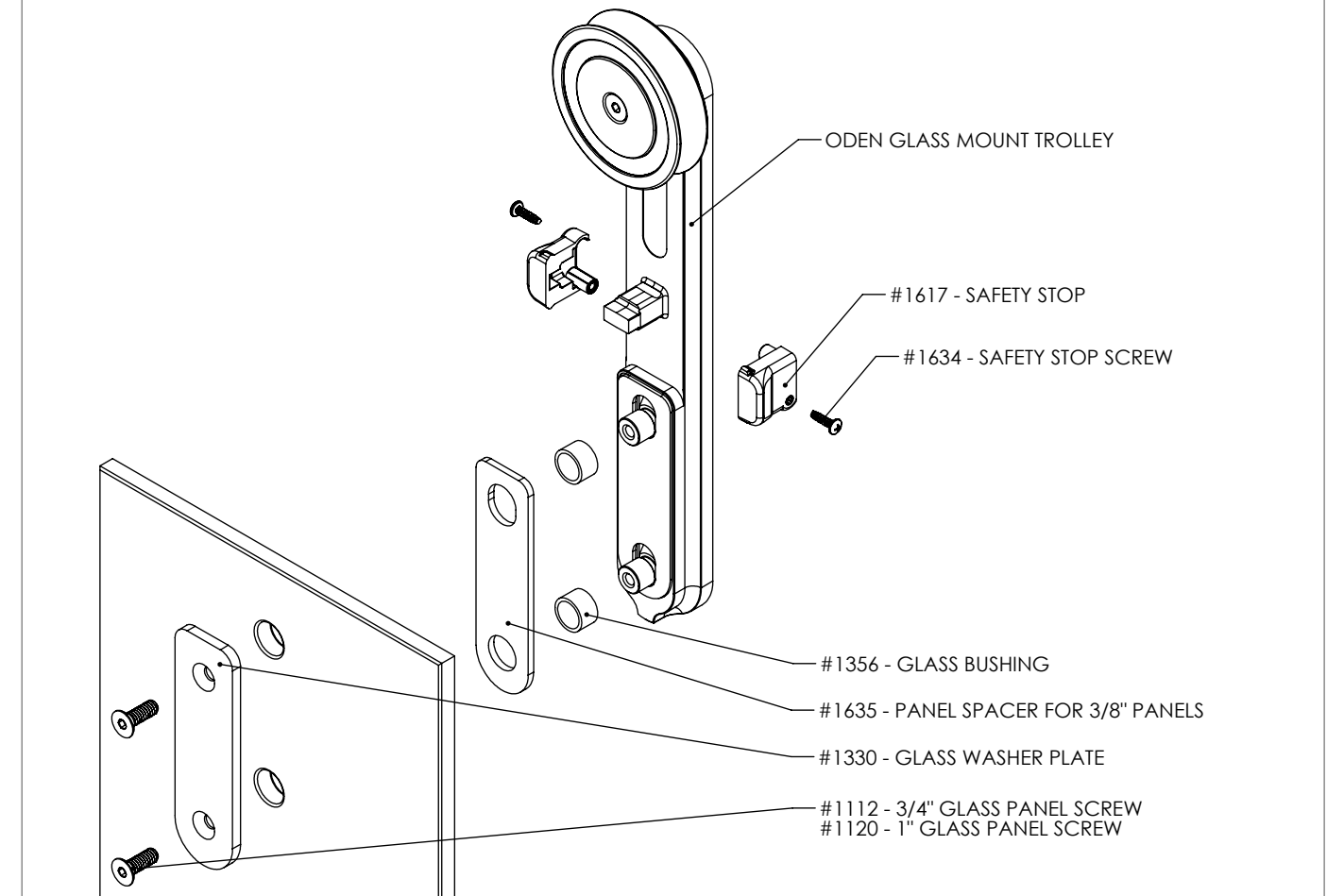

* = THE DOOR GUIDE MAY DIFFER - MULTIPLE OPTIONS EXIST

DOCUMENT:	PRODUCT SPECIFICATIONS - DOOR CONFIGURATIONS	DOOR APPLICATION:	SINGLE, BI-PARTING, BYPASSING	DRAWING SCALE:	3/8" = 1'-0" (1:32)	KROWNLAB 2351 NW York St. Portland, OR 97210 +1 503 292 6998 www.krownlab.com support@krownlab.com
SYSTEM:	TRU-LEVEL™ TRACK	PANEL THICKNESS:	TROLLEY SYSTEM OR TRACK CONFIGURATION DEPENDENT	UNITS:	INCHES	
MOUNTING STYLE:	FRAMED WALL	MAXIMUM WEIGHT:	TROLLEY SYSTEM OR TRACK CONFIGURATION DEPENDENT	DATE:	3/12/2018	



SINGLE

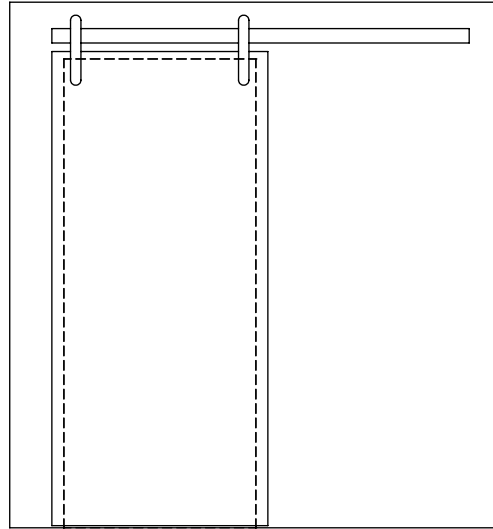

BI-PARTING

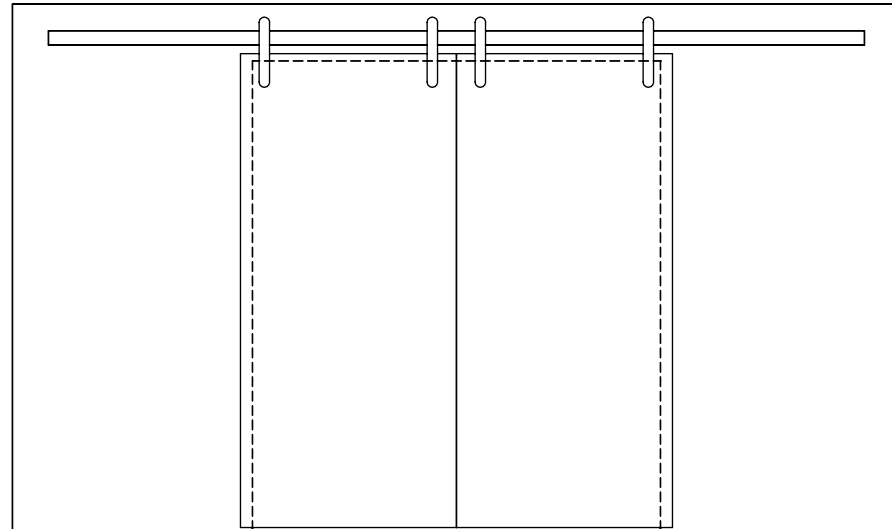

BYPASSING

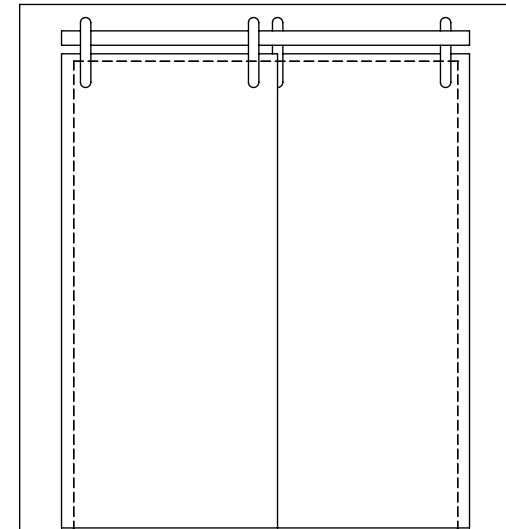

BI-PARTING-BYPASSING

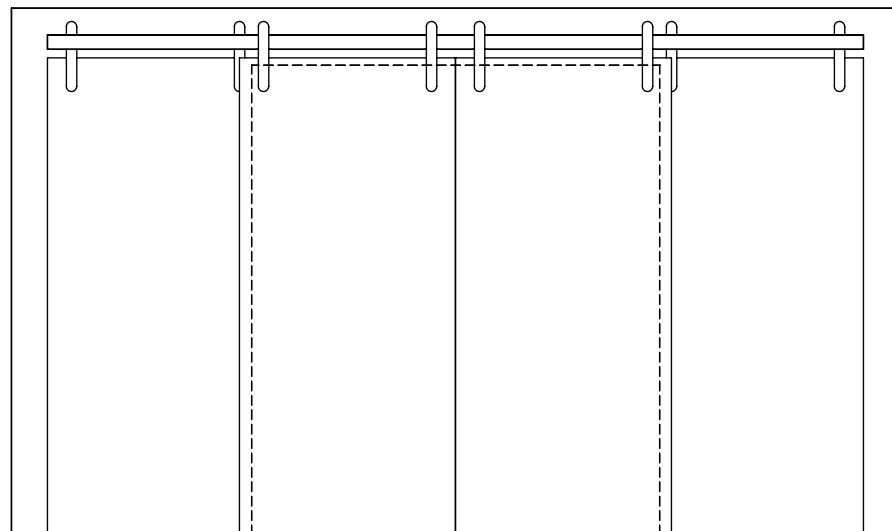

BYPASSING STACKED

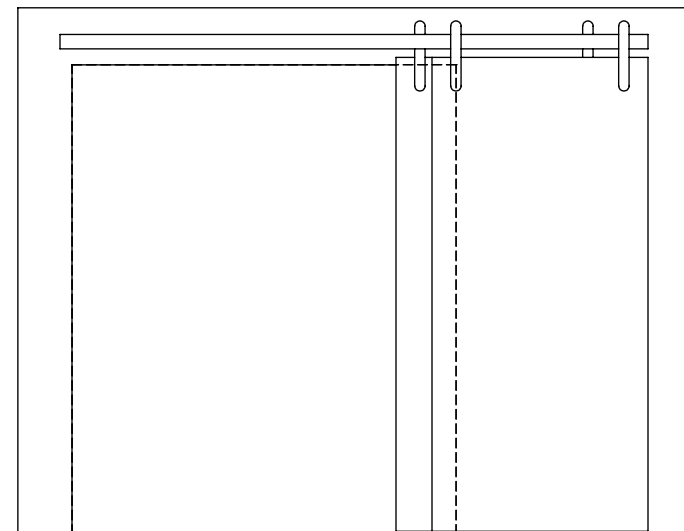

DOCUMENT:	PRODUCT SPECIFICATIONS	DOOR APPLICATION:	SINGLE, BI-PARTING, BYPASSING	DRAWING SCALE:	6" = 1'-0" (1:2)	KROWNLAB 2351 NW York St. Portland, OR 97210 +1 503 292 6998 www.krownlab.com support@krownlab.com	 PDX - ORE
SYSTEM:	TRU-LEVEL™ TRACK	PANEL THICKNESS:	TROLLEY SYSTEM DEPENDENT	UNITS:	INCHES		
MOUNTING STYLE:	FRAMED WALL	MAXIMUM WEIGHT:	TROLLEY SYSTEM DEPENDENT	DATE:	7/17/2019		

WHAT'S INCLUDED:
 1 x - #Txxxx - TRU-LEVEL™ TRACK SYSTEM WITH ALL MOUNTING HARDWARE:
 X x - #A252 - STANDARD TRACK MOUNTING KIT
 2 x - #A214 - DOOR STOP KIT
 X x - #A213 - TRACK CONNECTOR KIT (1 x PER TRACK JOINT INLCUED)

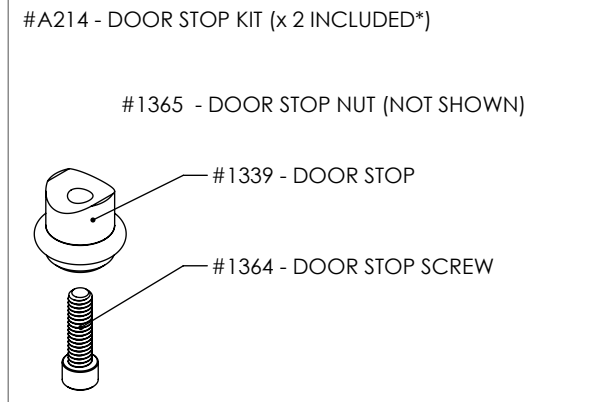

* = THE DOOR STOP MAY DIFFER - MULTIPLE OPTIONS EXIST
 VISIT WWW.KROWNLAB.COM FOR ALL OPTIONS

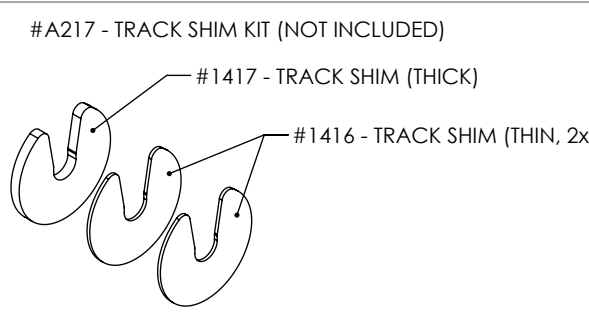

TRACK SHIMS ARE DESIGNED TO BE INSTALLED AGAINST TRACK

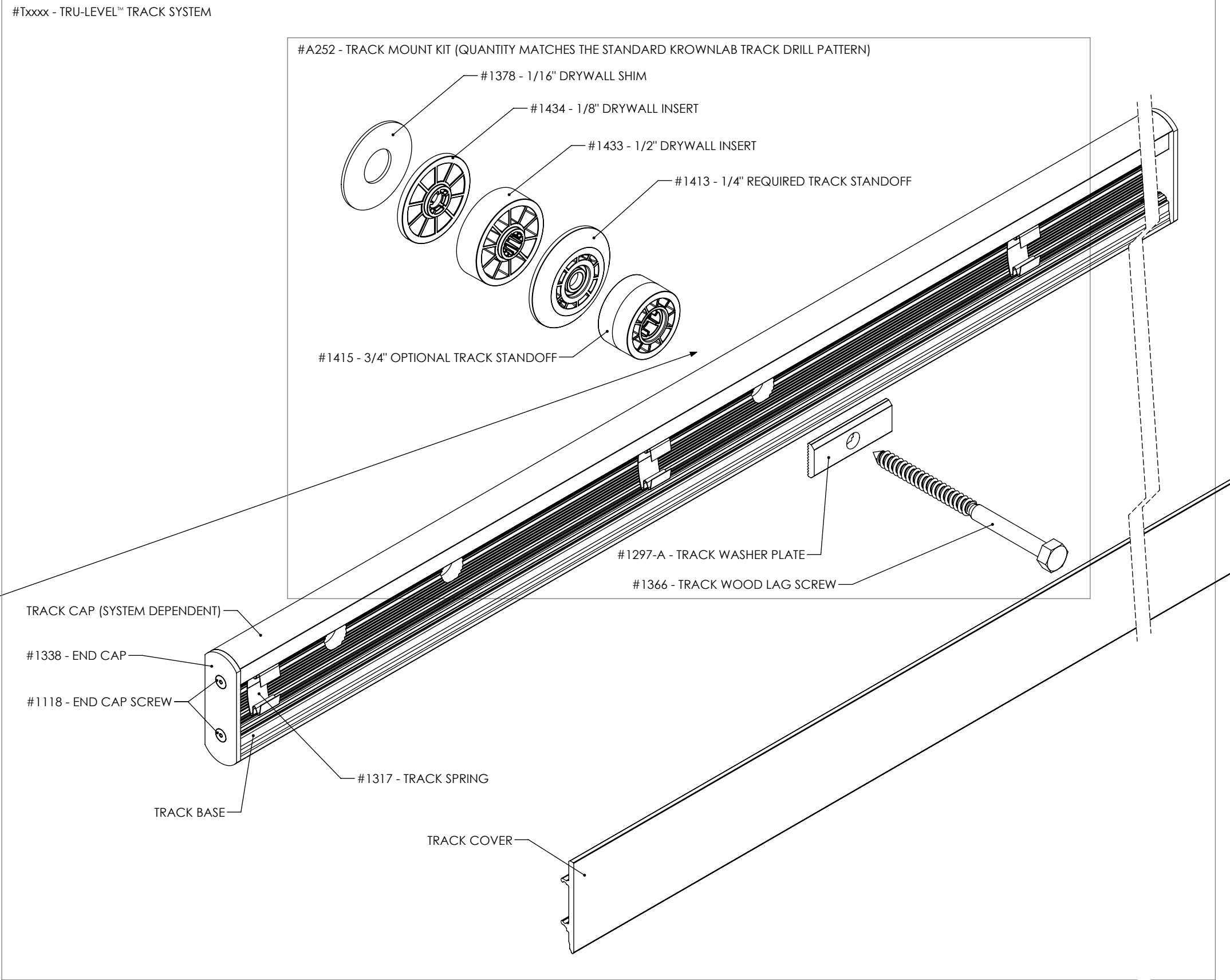
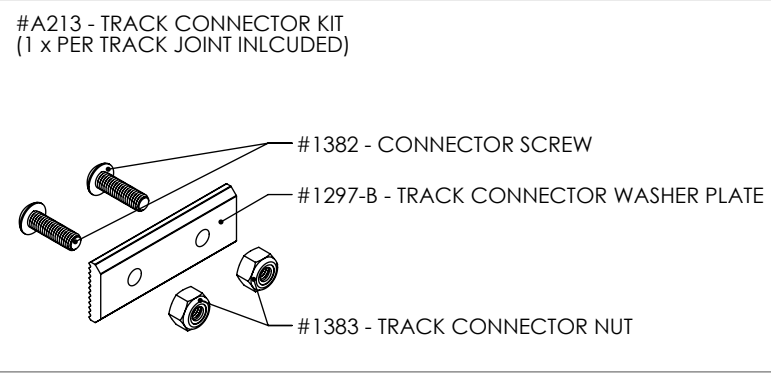

DOCUMENT:	PRODUCT SPECIFICATIONS - STANDARD TRACK MOUNTING POINT	DOOR APPLICATION:	SINGLE, BI-PARTING, BYPASSING	DRAWING SCALE:	6" = 1'-0" (1:2)	KROWNLAB 2351 NW York St. Portland, OR 97210 +1 503 292 6998 www.krownlab.com support@krownlab.com
SYSTEM:	TRU-LEVEL™ TRACK	PANEL THICKNESS:	TROLLEY SYSTEM DEPENDENT	UNITS:	INCHES	
MOUNTING STYLE:	FRAMED WALL	MAXIMUM WEIGHT:	TROLLEY SYSTEM DEPENDENT	DATE:	3/12/2018	

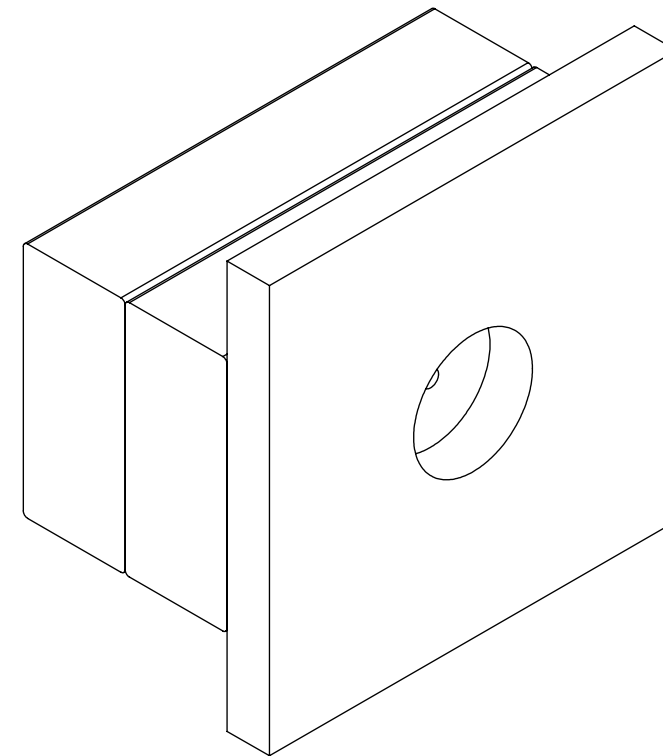
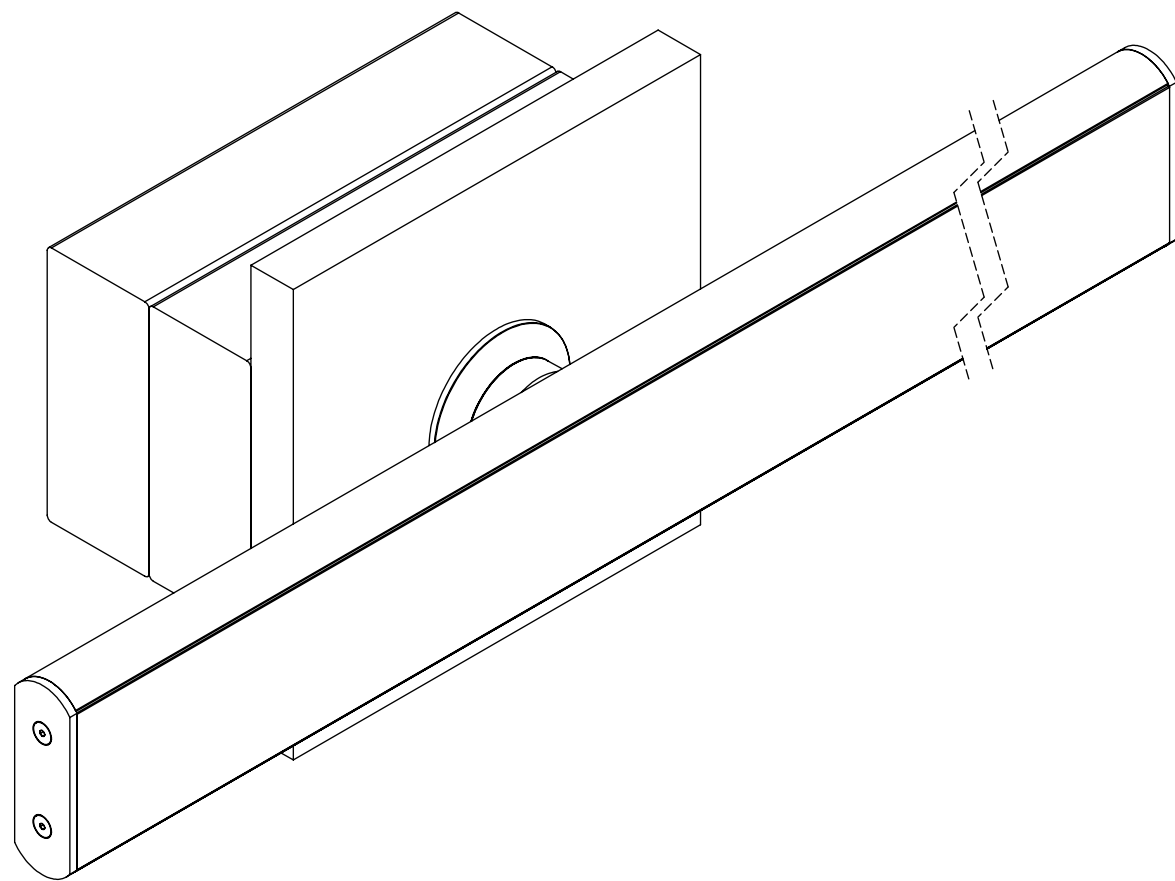
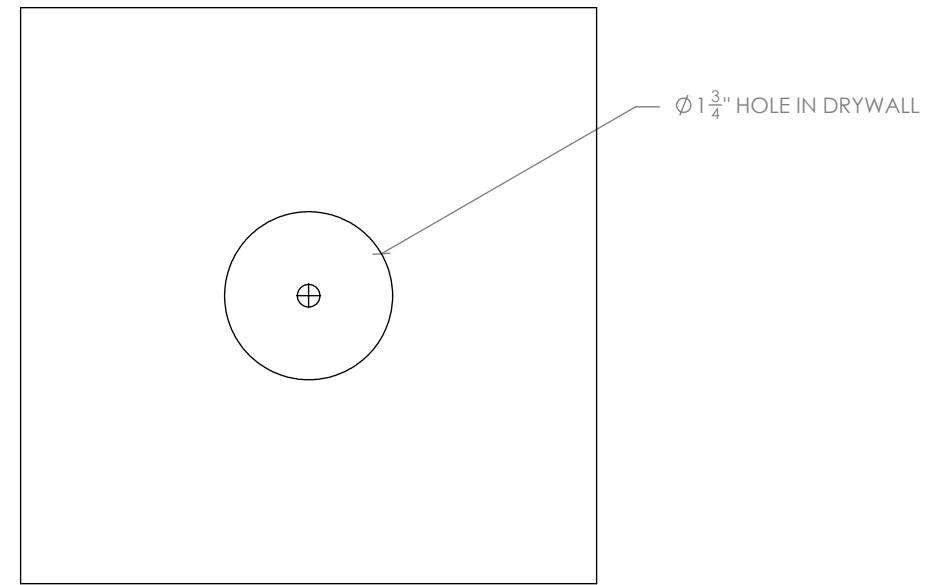
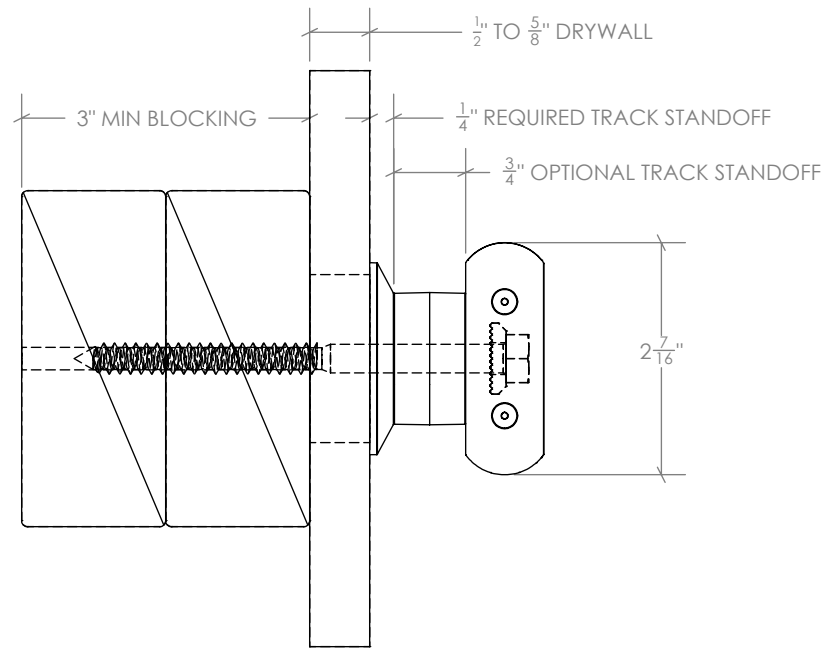

DOCUMENT:	PRODUCT SPECIFICATIONS - TRACK CONNECTOR	DOOR APPLICATION:	SINGLE & BI-PARTING	DRAWING SCALE:	6" = 1'-0" (1:2)	KROWNLAB 2351 NW York St. Portland, OR 97210 +1 503 292 6998 www.krownlab.com support@krownlab.com	
SYSTEM:	TRU-LEVEL™ TRACK	PANEL THICKNESS:	TROLLEY SYSTEM DEPENDENT	UNITS:	INCHES		
MOUNTING STYLE:	ALL WALL TYPES	MAXIMUM WEIGHT:	TROLLEY SYSTEM DEPENDENT	DATE:	3/12/2018		

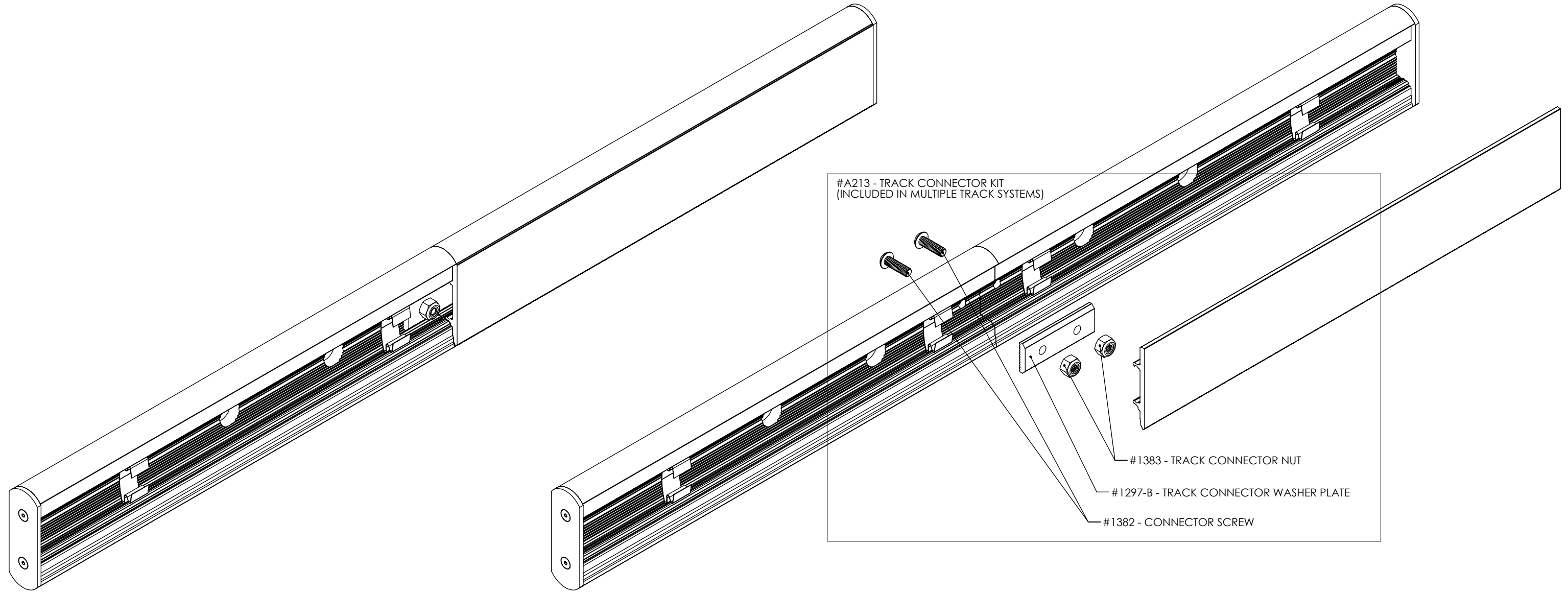
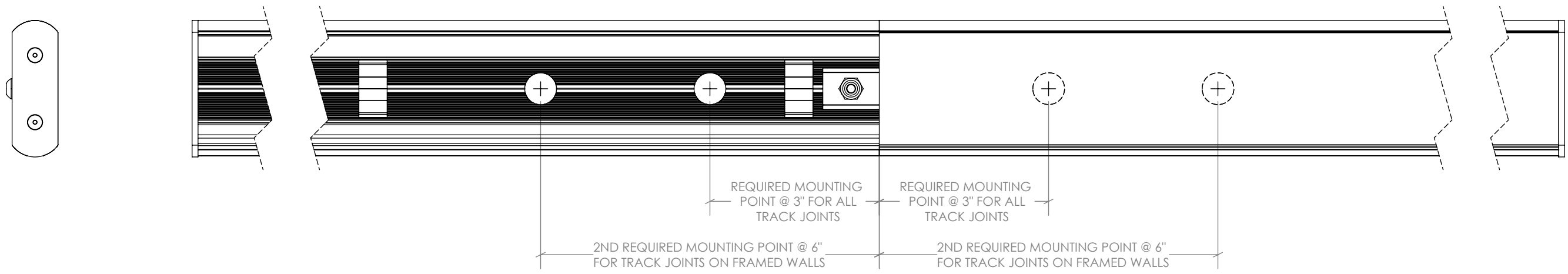

DOCUMENT:	PRODUCT SPECIFICATIONS - PERPENDICULAR TRACK MOUNTING POINT
SYSTEM:	TRU-LEVEL™ TRACK
MOUNTING STYLE:	FRAMED WALL, TILED WALL, GLASS WALL

DOOR APPLICATION:	ALL
PANEL THICKNESS:	3/8" TO 1/2" (CONTACT US FOR PANELS OUTSIDE OF THIS RANGE)
MAXIMUM WEIGHT:	TROLLEY SYSTEM OR TRACK CONFIGURATION DEPENDENT

DRAWING SCALE:	3/4" = 1'-0" (1:16)
UNITS:	INCHES
DATE:	12/28/2018

KROWNLAB
2351 NW York St.
Portland, OR 97210
+1 503 292 6998
www.krownlab.com
support@krownlab.com



PDX - ORE

PERPENDICULAR FRAMED WALL
SCALE: 3" = 1'-0" (1:4)

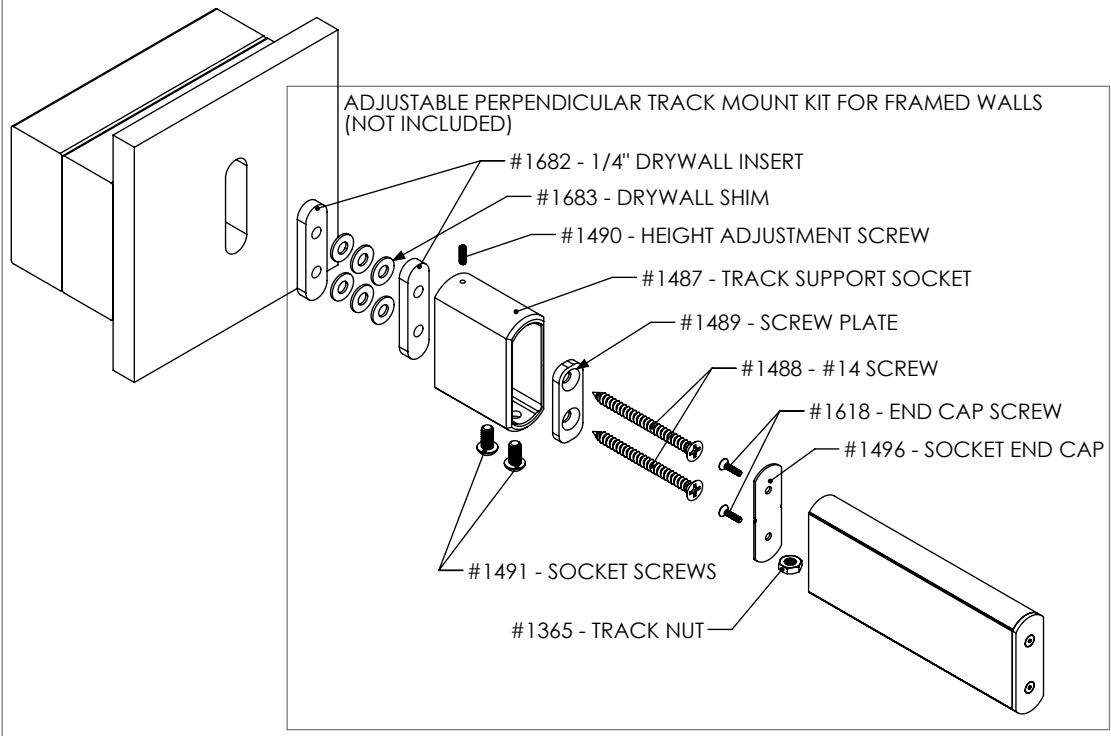
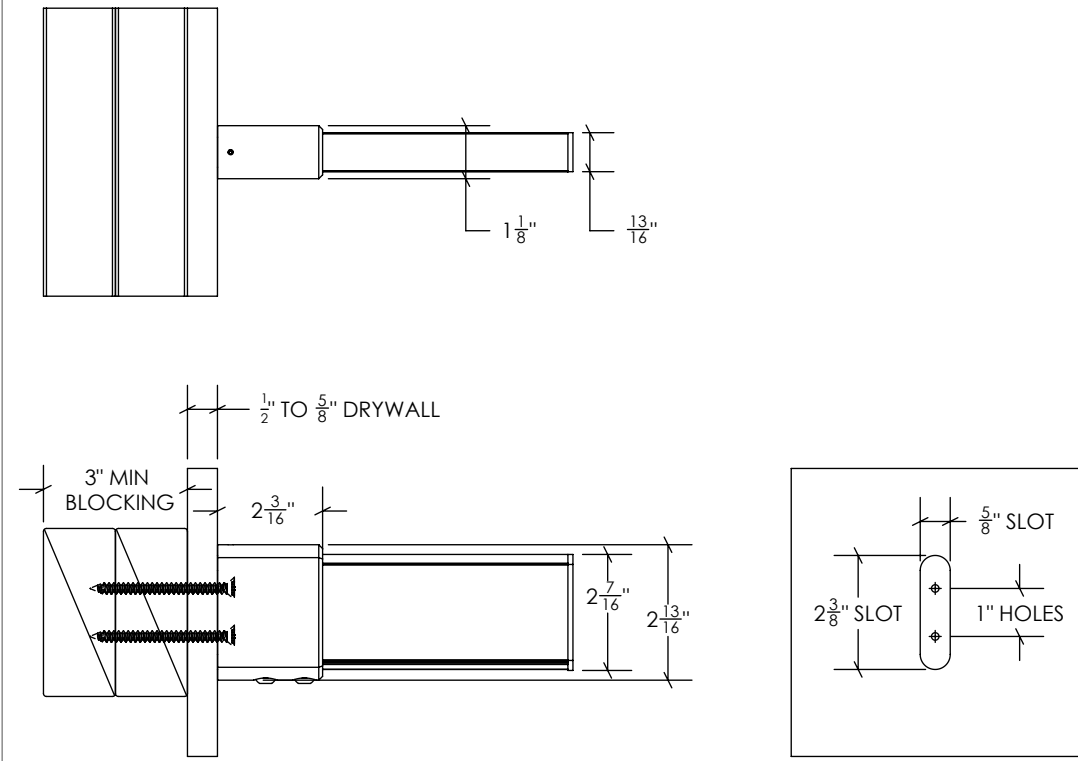

PERPENDICULAR TILE WALL
SCALE: 3" = 1'-0" (1:4)

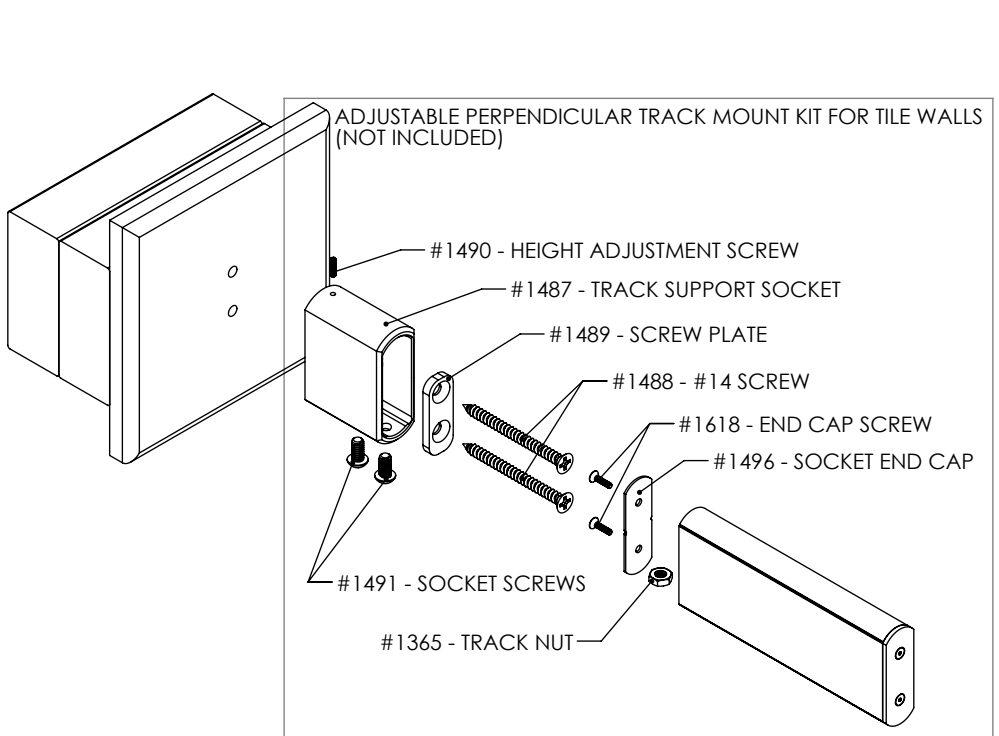
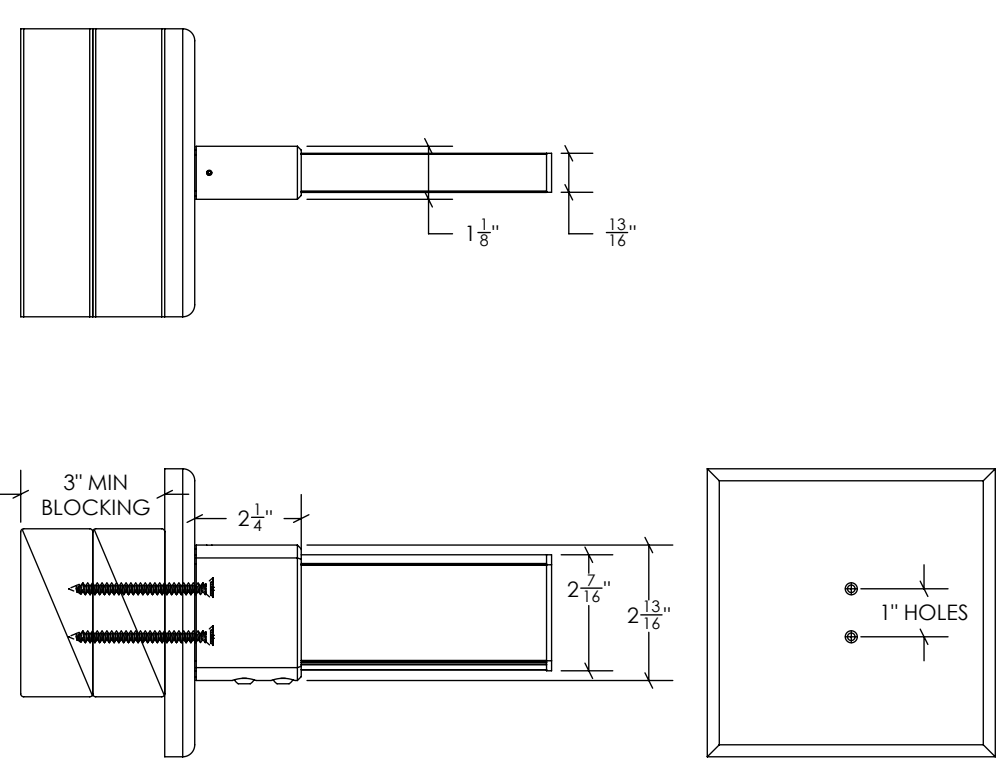

PERPENDICULAR GLASS WALL
SCALE: 3" = 1'-0" (1:4)

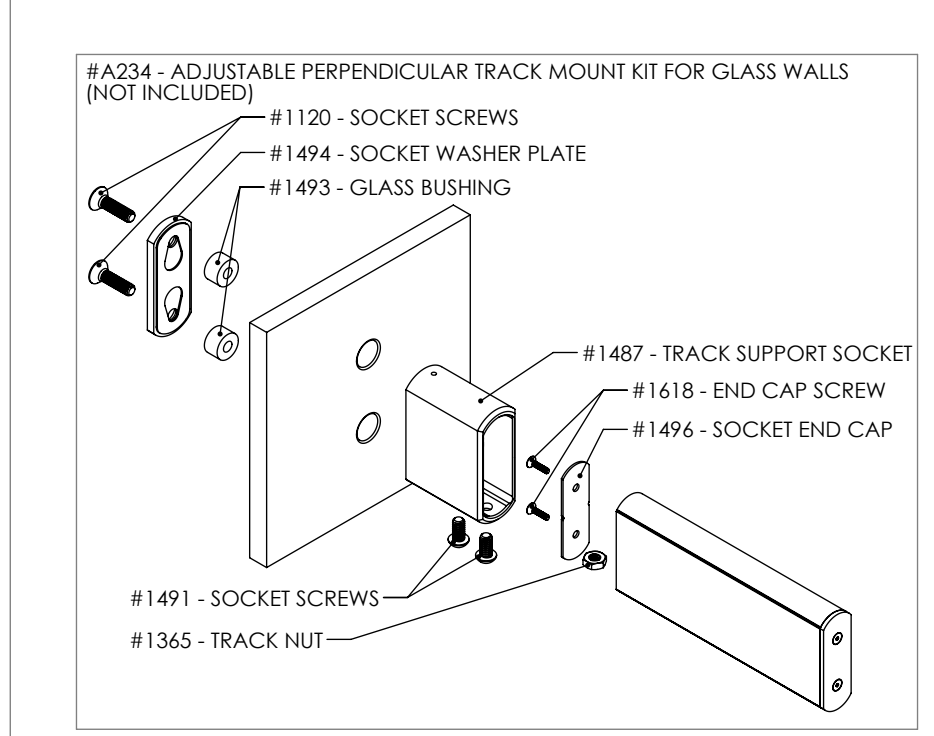
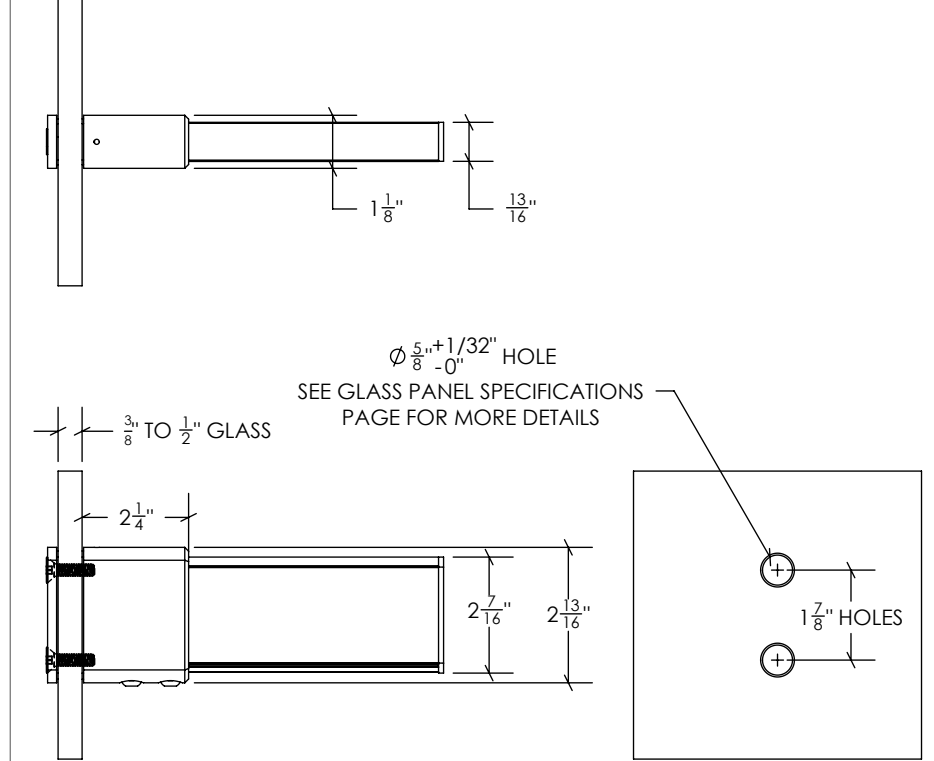

DOCUMENT:	PRODUCT SPECIFICATIONS - PERPENDICULAR TRACK MOUNTING POINT	DOOR APPLICATION:	SINGLE, BI-PARTING, BYPASSING	DRAWING SCALE:	3/4" = 1'-0" (1:16)	KROWNLAB 2351 NW York St. Portland, OR 97210 +1 503 292 6998 www.krownlab.com support@krownlab.com
SYSTEM:	TRU-LEVEL™ TRACK	PANEL THICKNESS:	TROLLEY SYSTEM DEPENDENT	UNITS:	INCHES	
MOUNTING STYLE:	FRAMED WALL	MAXIMUM WEIGHT:	TROLLEY SYSTEM OR TRACK CONFIGURATION DEPENDENT	DATE:	12/28/2018	



INSTALLED INTO STRUCTURAL BLOCKING (OPTIMAL)

SPAN (X)	MAX. PANEL WEIGHT
UP TO 38"	300lb
UP TO 44"	275lb
UP TO 50"	250lb
UP TO 62"	225lb

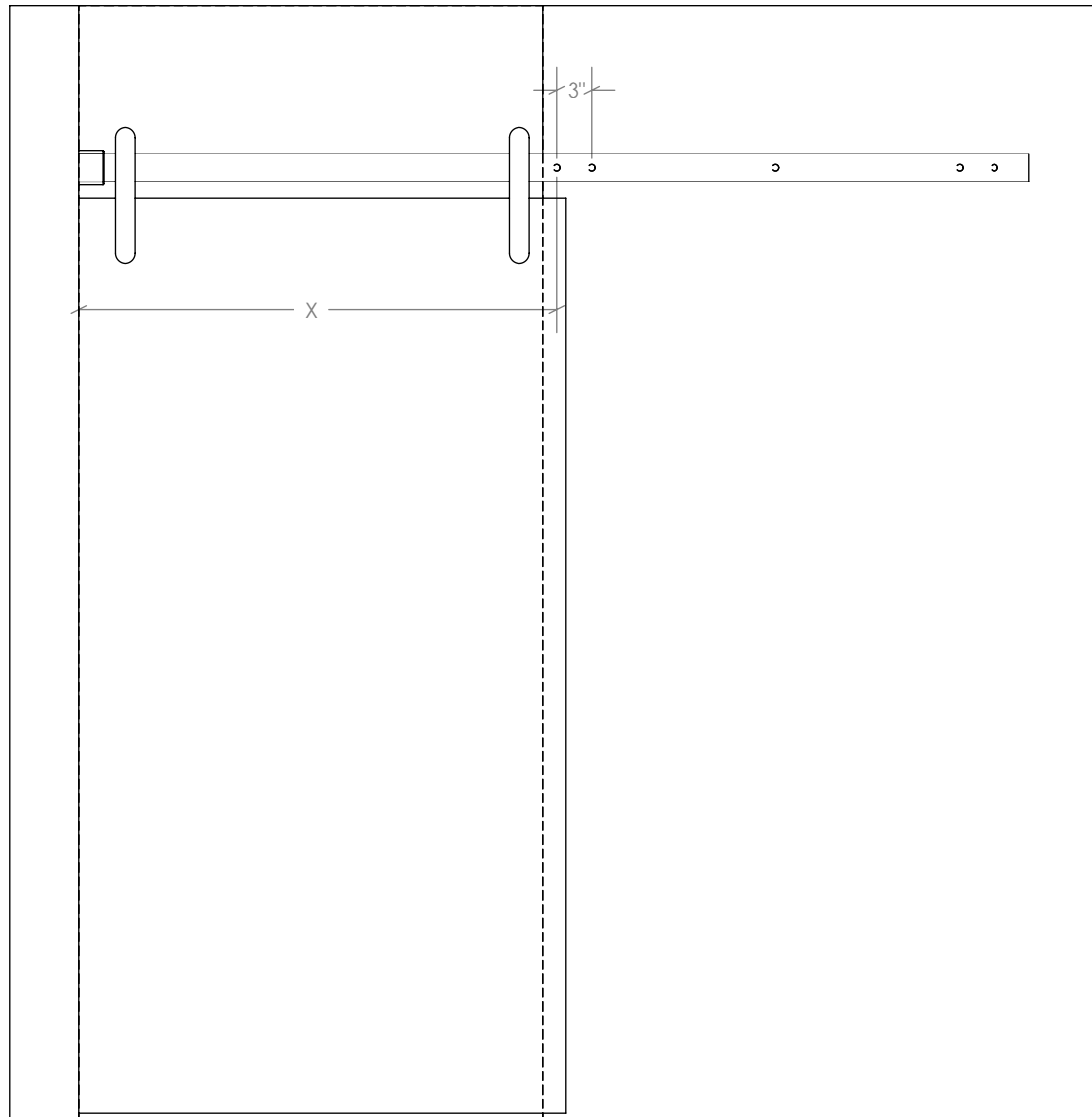

INSTALLED INTO WOOD STUDS

SPAN (X)	MAX. PANEL WEIGHT
UP TO 38"	150lb
UP TO 44"	125lb
UP TO 50"	100lb

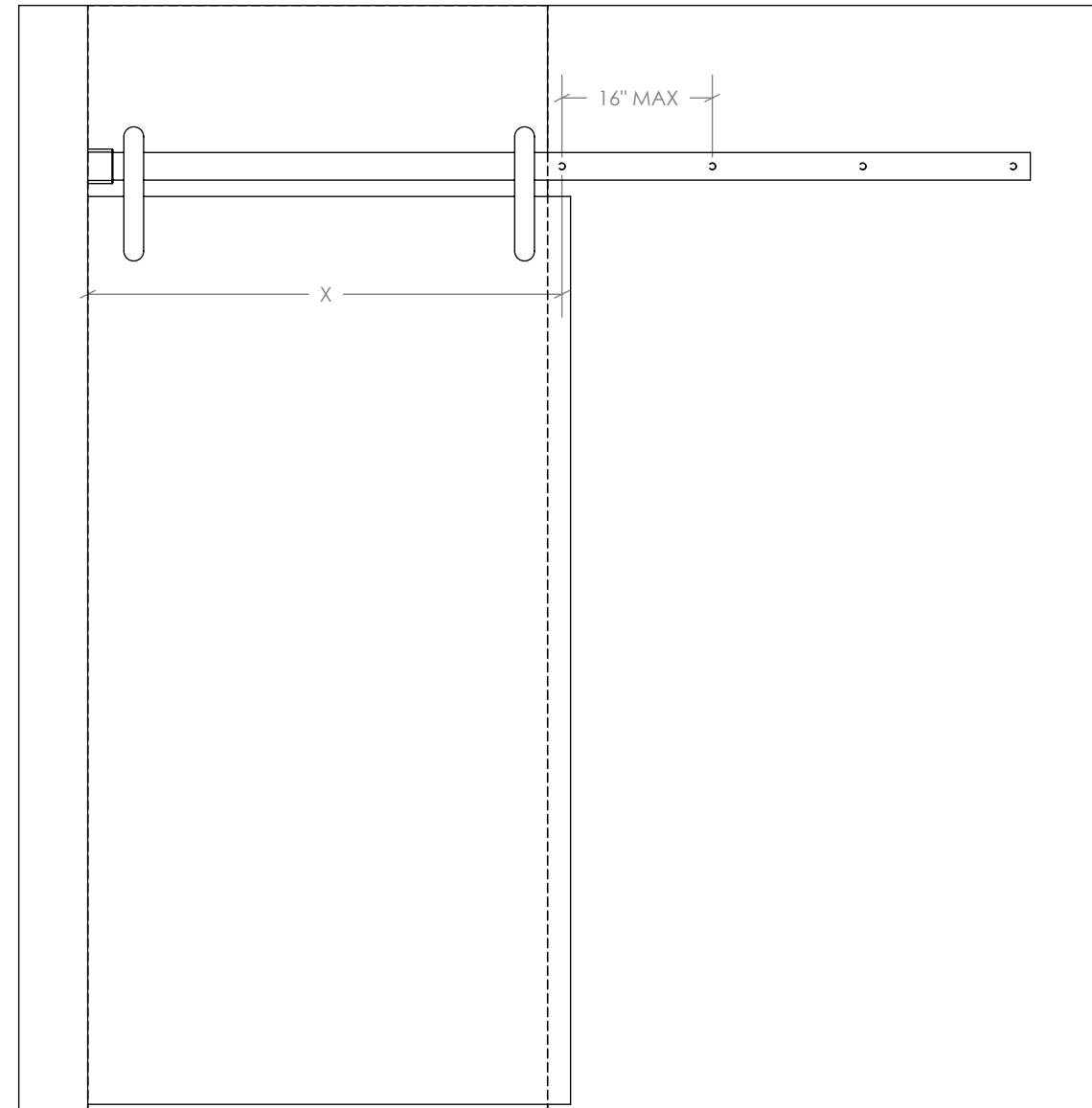

DOCUMENT: PRODUCT SPECIFICATIONS - BYPASSING WITH CENTER MOUNT
 SYSTEM: TRU-LEVEL™ TRACK
 MOUNTING STYLE: FRAMED WALL

DOOR APPLICATION: BYPASSING
 PANEL THICKNESS: TROLLEY SYSTEM OR BYPASSING DEPENDENT
 MAXIMUM WEIGHT: TROLLEY SYSTEM OR TRACK LENGTH DEPENDENT

DRAWING SCALE: 1" = 1'-0" (1:12)
 UNITS: INCHES
 DATE: 9/13/2019

KROWNLAB
 2351 NW York St.
 Portland, OR 97210
 +1 503 292 6998
 www.krownlab.com
 support@krownlab.com

KROWNLAB
 PDX - ORE

BYPASSING TRACKS ARE ONLY AVAILABLE MADE-TO-MEASURE AND PRE-DRILLED.
 IT IS RECOMMENDED TO CONTACT US BEFORE ORDERING DOOR PANELS TO OPTIMIZE DOOR TRAVEL.

COMBINED TOTAL PANEL WIDTH SHOULD BE WIDER THAN THE OPENING BY 14" MINIMUM TO OPTIMIZE DOOR TRAVEL:

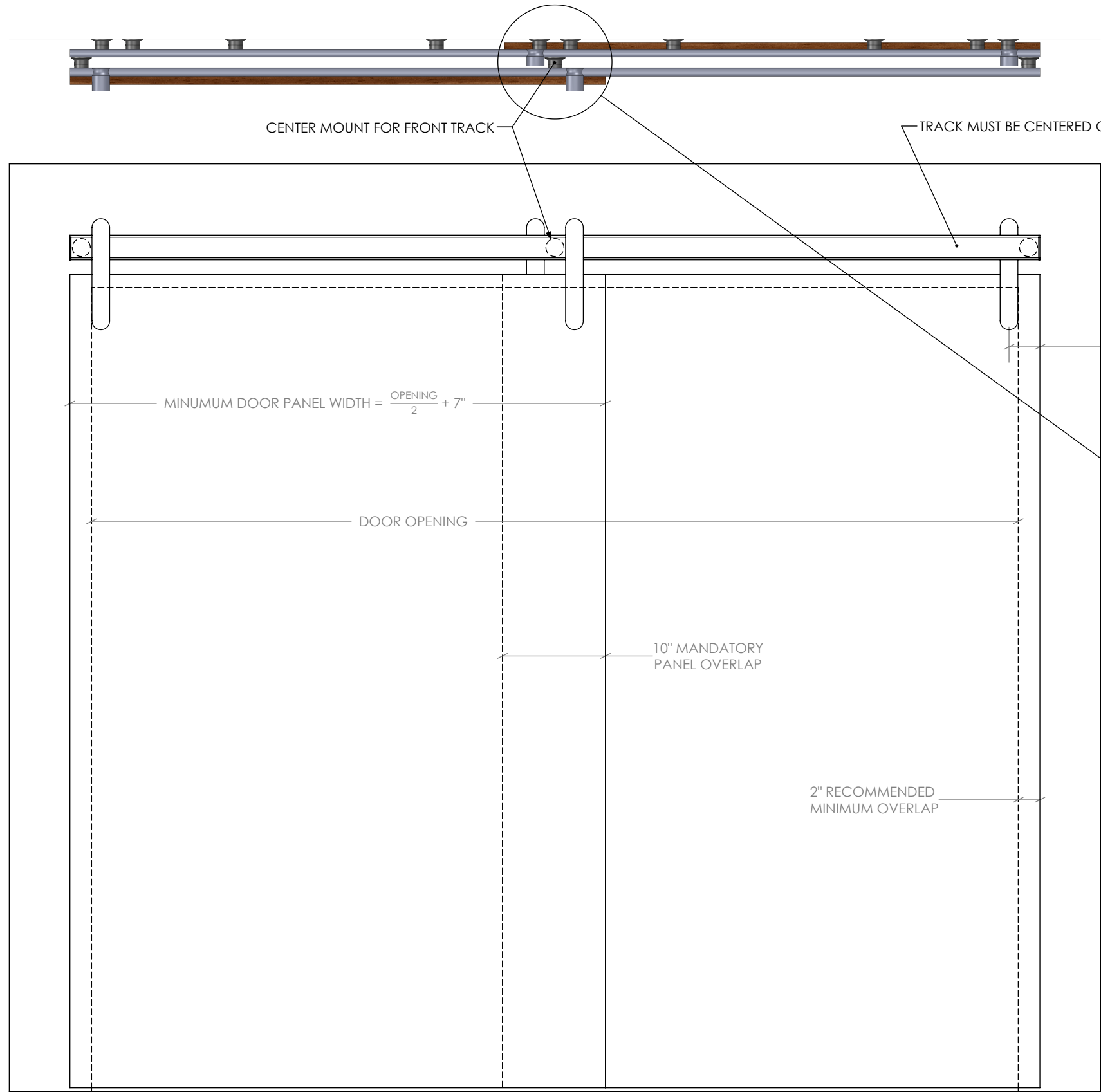

TRACK LENGTH	MAX. PANEL WEIGHT*
UP TO 9FT	225lb
UP TO 11FT	200lb
UP TO 12FT	175lb

*EACH PANEL

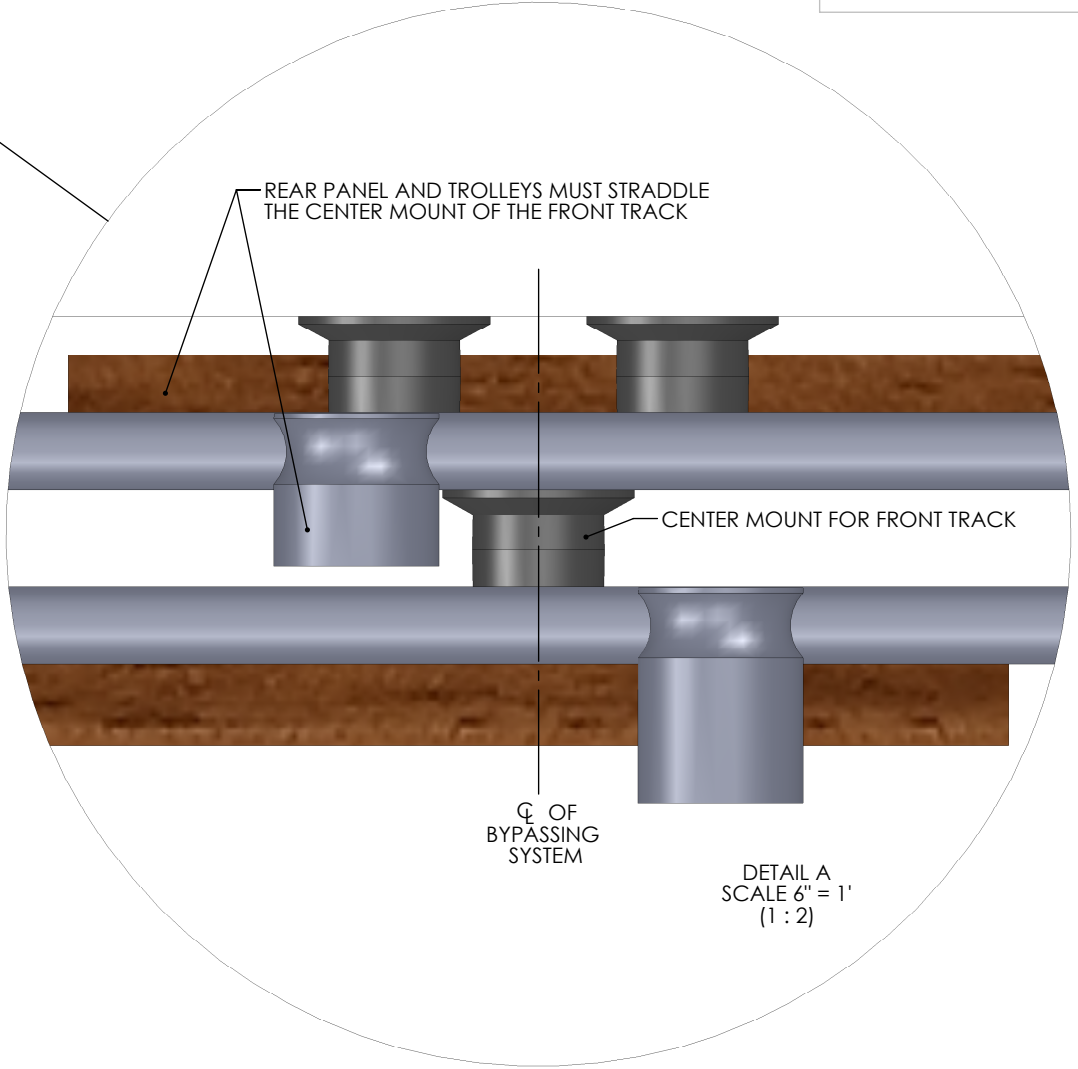
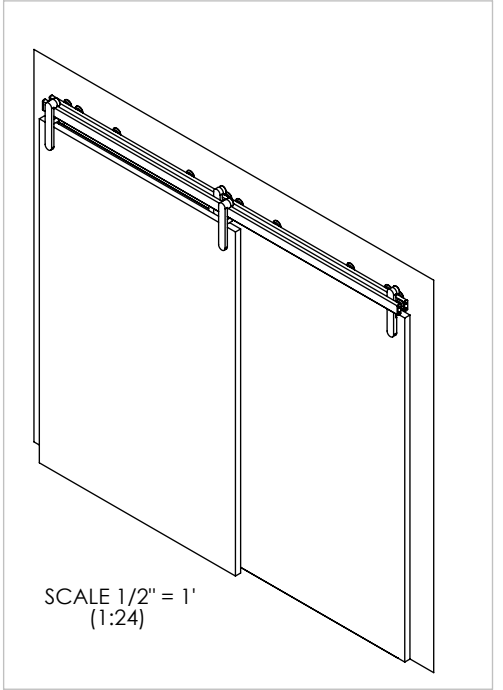

DOCUMENT:	PRODUCT SPECIFICATIONS - BYPASSING WITHOUT CENTER MOUNT	DOOR APPLICATION:	BYPASSING	DRAWING SCALE:	1" = 1'-0" (1:12)	KROWNLAB 2351 NW York St. Portland, OR 97210 +1 503 292 6998 www.krownlab.com support@krownlab.com
SYSTEM:	TRU-LEVEL™ TRACK	PANEL THICKNESS:	TROLLEY SYSTEM OR BYPASSING DEPENDENT	UNITS:	INCHES	
MOUNTING STYLE:	FRAMED WALL	MAXIMUM WEIGHT:	TRACK LENGTH DEPENDENT	DATE:	11/30/2018	



BYPASSING TRACKS ARE ONLY AVAILABLE MADE-TO-MEASURE AND PRE-DRILLED.
IT IS RECOMMENDED TO CONTACT US BEFORE ORDERING DOOR PANELS TO OPTIMIZE DOOR TRAVEL.

COMBINED TOTAL PANEL WIDTH SHOULD BE WIDER THAN THE OPENING BY 6" MINIMUM TO OPTIMIZE DOOR TRAVEL:

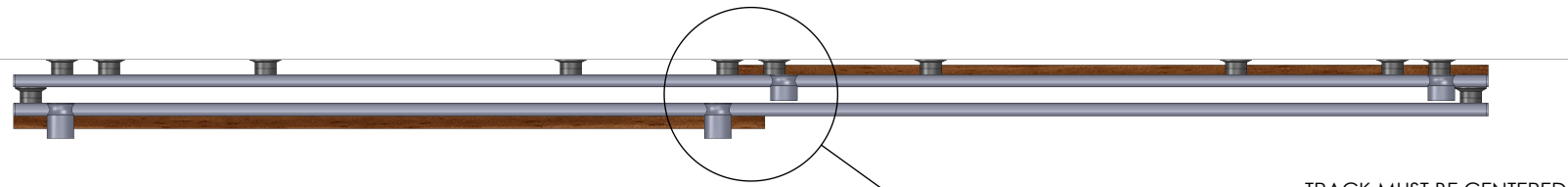

TRACK MUST BE CENTERED OVER OPENING

TRACK LENGTH	MAX. PANEL WEIGHT*
UP TO 4FT	150lb
UP TO 5FT	125lb
UP TO 6FT	85lb

*EACH PANEL

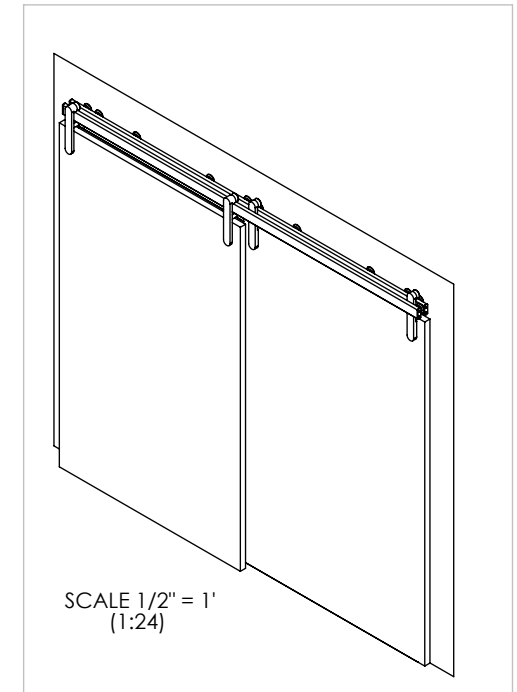

SCALE 1/2" = 1'
(1:24)

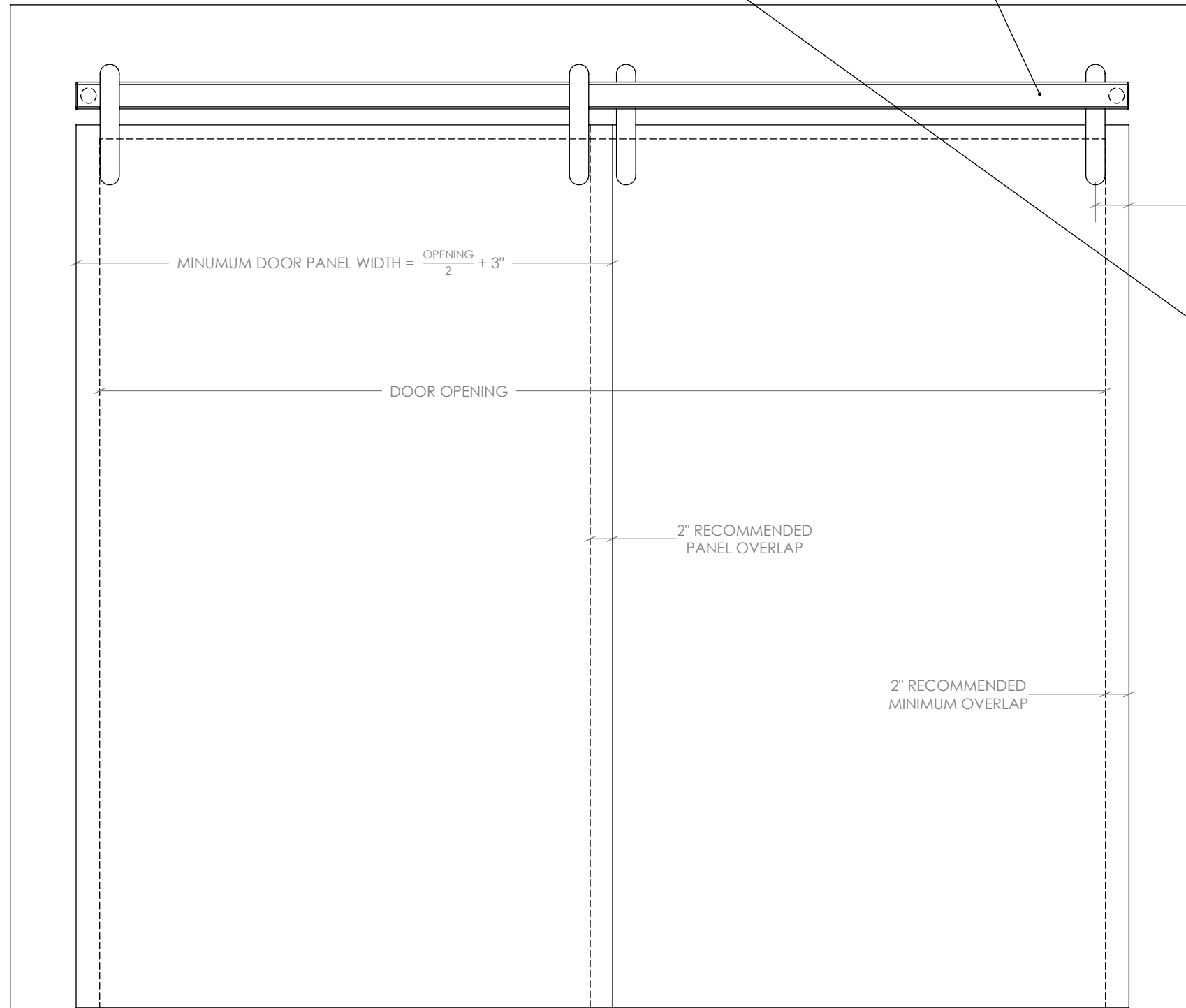

3" MINIMUM FOR BYPASSING SYSTEMS

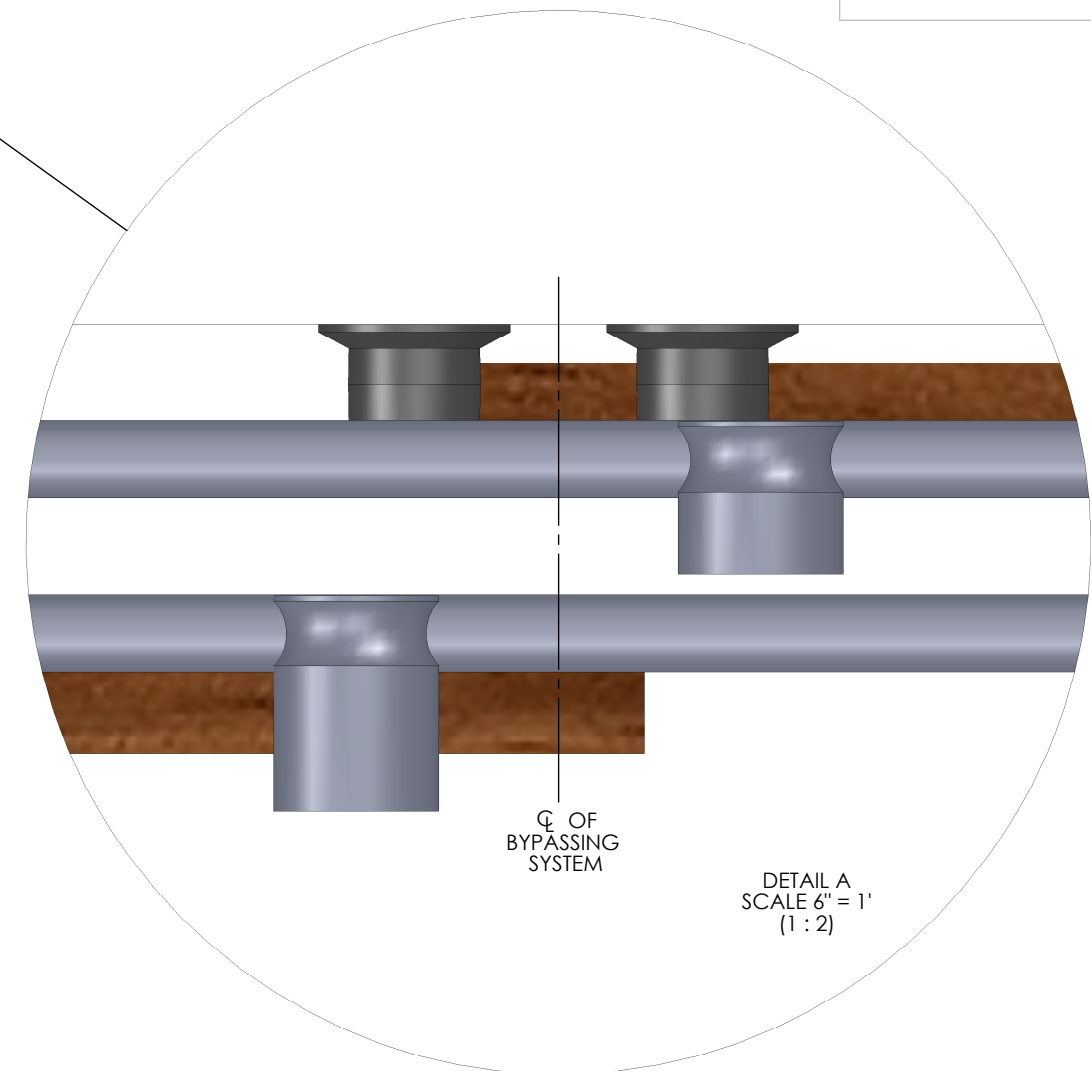

C.G. OF BYPASSING SYSTEM

DETAIL A
SCALE 6" = 1'
(1:2)

DOCUMENT:	PRODUCT SPECIFICATIONS - BYPASSING STACKED	DOOR APPLICATION:	BYPASSING STACKED	DRAWING SCALE:	1" = 1'-0" (1:12)	KROWNLAB 2351 NW York St. Portland, OR 97210 +1 503 292 6998 www.krownlab.com support@krownlab.com	
SYSTEM:	TRU-LEVEL™ TRACK	PANEL THICKNESS:	TROLLEY SYSTEM OR BYPASSING DEPENDENT	UNITS:	INCHES		
MOUNTING STYLE:	FRAMED WALL	MAXIMUM WEIGHT:	TRACK CONFIGURATION, TRACK LENGTH OR TROLLEY SYSTEM DEPENDENT	DATE:	11/30/2018		

BYPASSING STACKED TRACKS ARE ONLY AVAILABLE MADE-TO-MEASURE AND PRE-DRILLED.
IT IS RECOMMENDED TO CONTACT US BEFORE ORDERING DOOR PANELS TO OPTIMIZE DOOR TRAVEL.

COMBINED TOTAL PANEL WIDTH SHOULD BE WIDER THAN THE OPENING BY THE FOLLOWING AMOUNT TO OPTIMIZE DOOR TRAVEL:
WITH OPTIONAL CENTER MOUNT: 14" MINIMUM*
WITHOUT OPTIONAL CENTER MOUNT: 6" MINIMUM*

FRONT TRACK SUPPORT REGION
ONLY THE FRONT PANEL CAN REACH THIS SECTION.

BYPASSING TRACK REGION (WITH OR WITHOUT OPTIONAL CENTER MOUNT)
THE REAR PANEL IS RESTRICTED TO MOVEMENT WITHIN THIS SECTION.



OPTIONAL CENTER MOUNT (SEE PREVIOUS PAGES FOR MAX PANEL WEIGHT IMPLICATIONS)

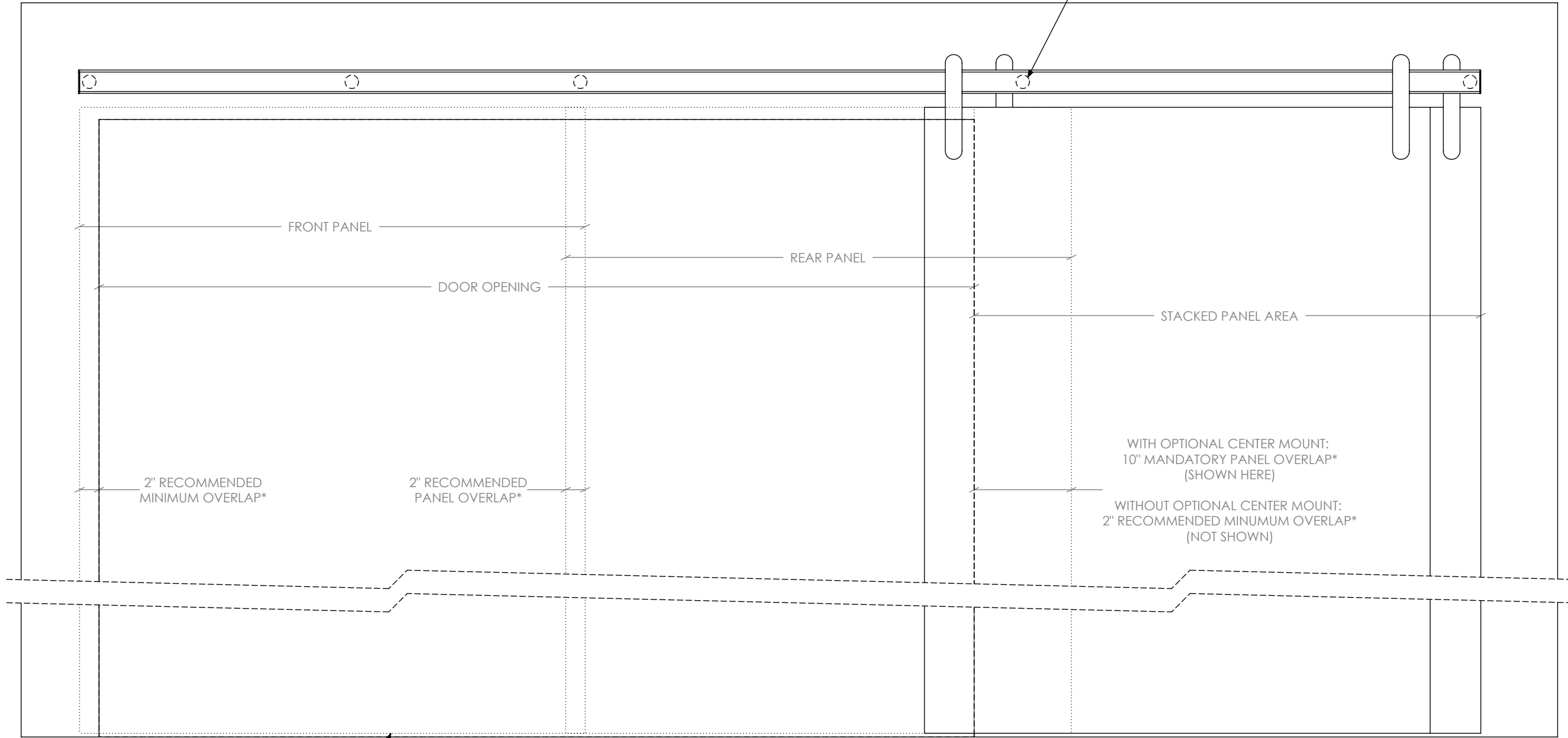

FRONT PANEL WILL REQUIRE SPECIAL BOTTOM GUIDE ACCOMODATIONS. CONTACT KROWNLAB FOR DETAILS.

* = THESE ARE MINIMUMS. EXCEEDING THESE VALUES IS RECOMMENDED TO INCREASE PRIVACY IN SOME INSTALLATIONS.

DOCUMENT: PRODUCT SPECIFICATIONS - BYPASSING PANEL CLEARANCE
 SYSTEM: TRU-LEVEL™ TRACK
 MOUNTING STYLE: FRAMED WALL

DOOR APPLICATION: BYPASSING
 PANEL THICKNESS: TROLLEY SYSTEM OR BYPASSING DEPENDENT
 MAXIMUM WEIGHT: SYSTEM DEPENDENT AND TRACK LENGTH DEPENDENT

DRAWING SCALE: 1" = 1'-0" (1:2)
 UNITS: INCHES
 DATE: 3/12/2018

KROWNLAB
 2351 NW York St.
 Portland, OR 97210
 +1 503 292 6998
 www.krownlab.com
 support@krownlab.com



MOUNTING STYLE	PANEL THICKNESS*
TOP MOUNT	1-3/8" TO 2-1/2"
FACE MOUNT**	3/4" TO 1-3/8"
GLASS MOUNT	3/8" - 1/2"

*NOT ACCOUNTING FOR BASEBOARD (IF EXISTING) OR OPTIONAL DOOR PULLS
 **ODEN AND BALDUR ONLY

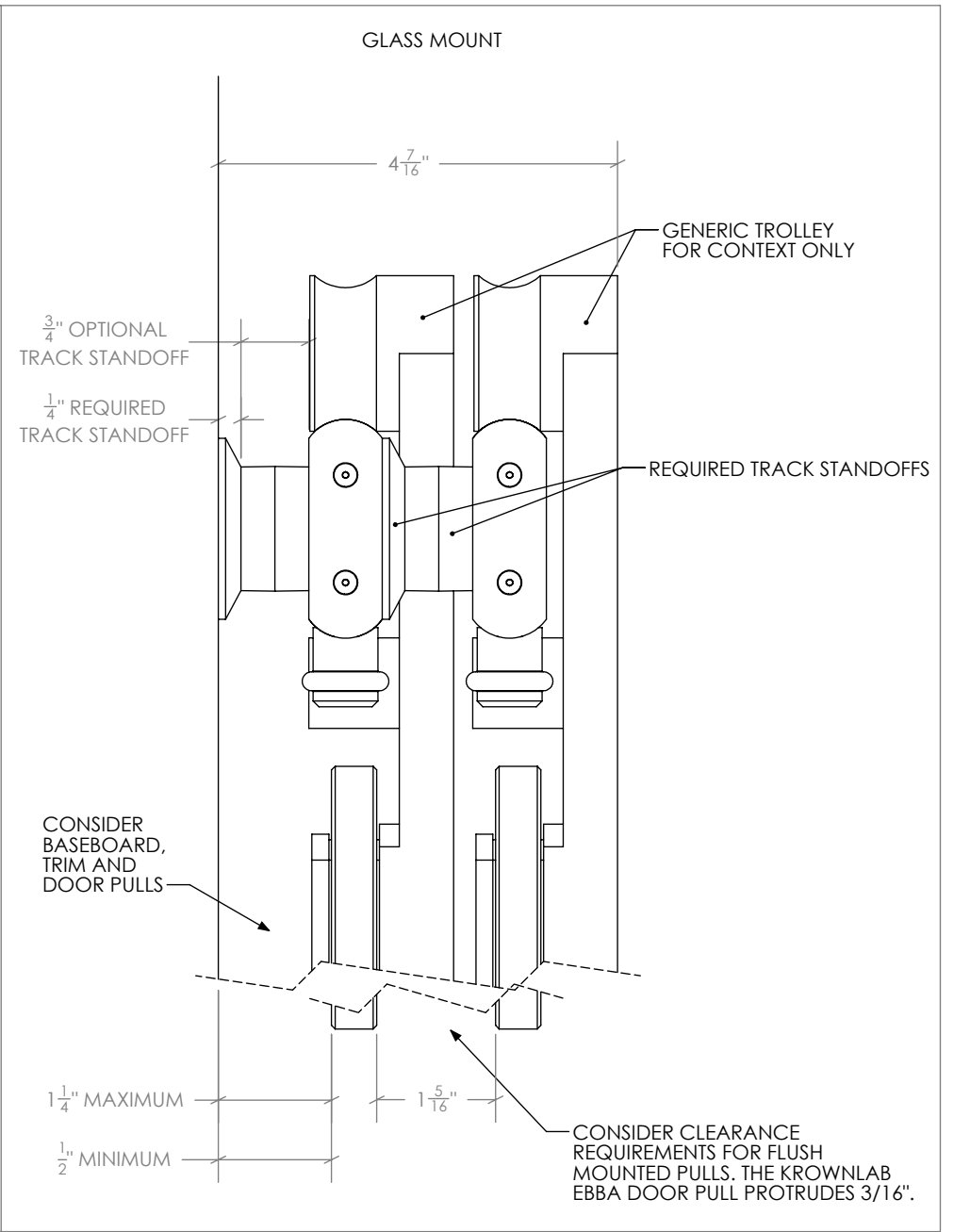
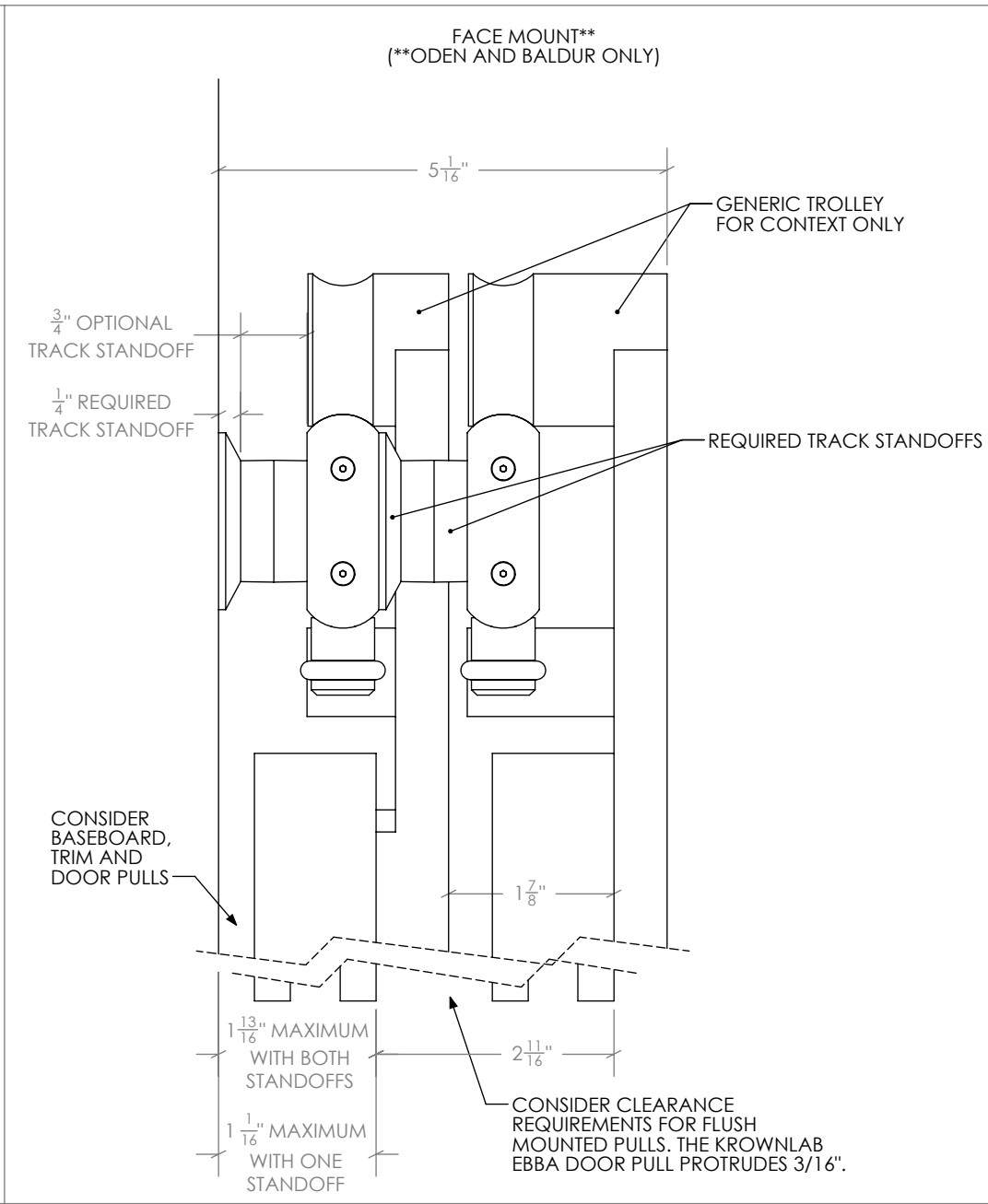
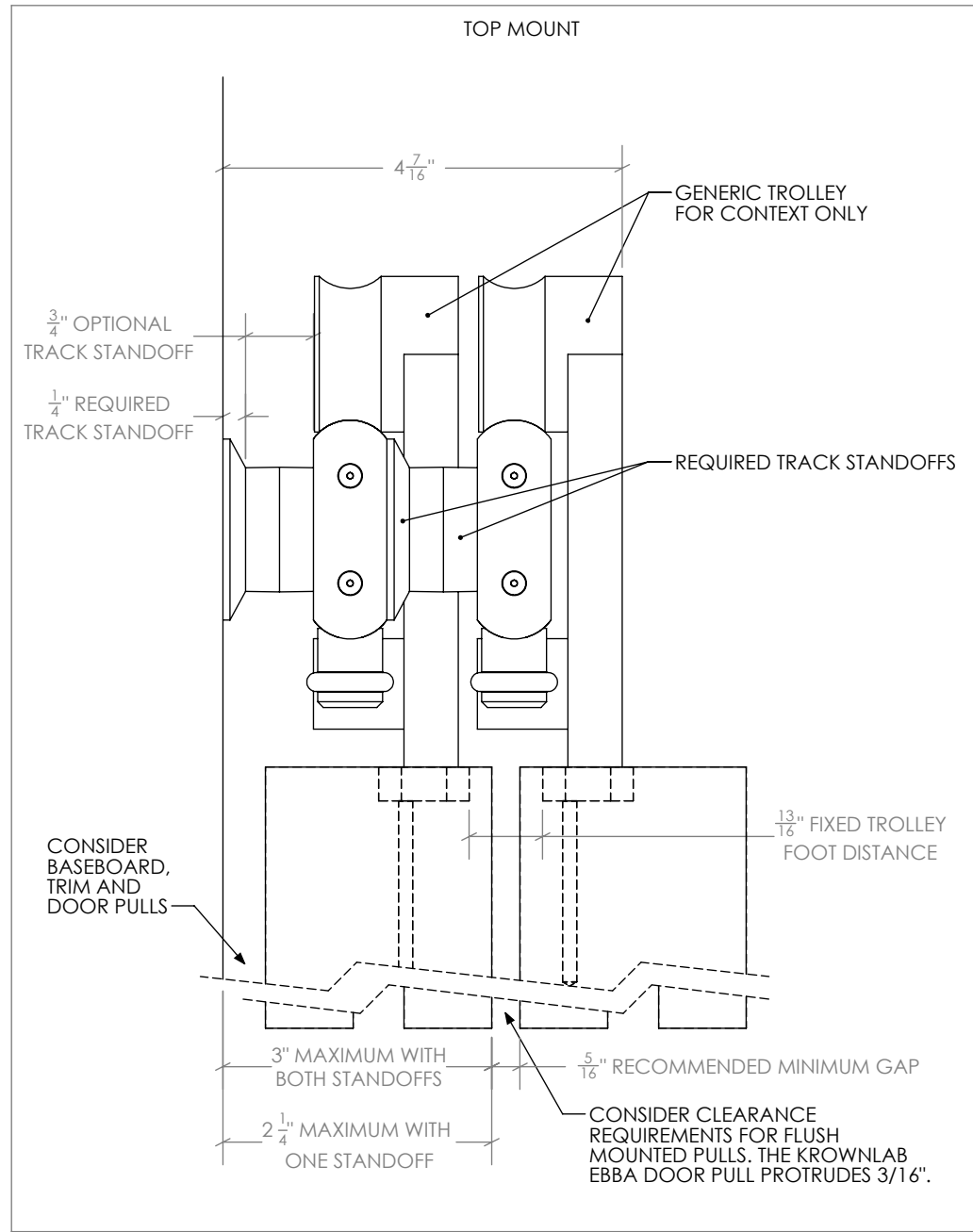

DOCUMENT:	PRODUCT SPECIFICATIONS - UNDRILLED TRACK DRILL PATTERN GUIDE	DOOR APPLICATION:	SINGLE & BI-PARTING	DRAWING SCALE:	1" = 1'-0" (1:12)	KROWNLAB 2351 NW York St. Portland, OR 97210 +1 503 292 6998 www.krownlab.com support@krownlab.com	
SYSTEM:	TRU-LEVEL™ TRACK	PANEL THICKNESS:	TROLLEY SYSTEM DEPENDENT	UNITS:	INCHES		
MOUNTING STYLE:	FRAMED WALL	MAXIMUM WEIGHT:	SEE BELOW	DATE:	9/25/2018		

STUD DRILL PATTERN: (250LB MAX* PER TRACK)

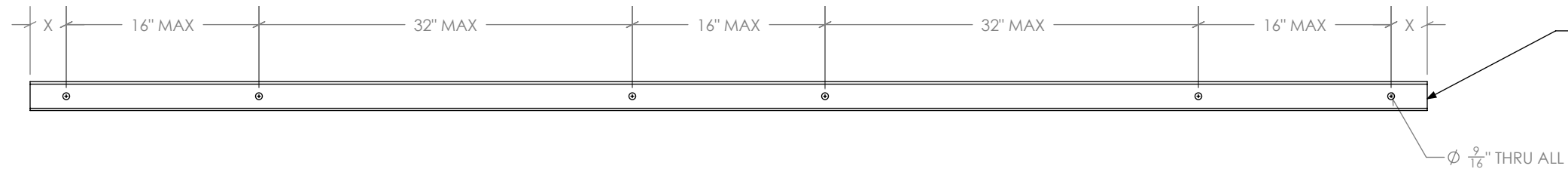

PANEL WEIGHT	X	MOUNTING POINTS
UP TO 100 LBS	5"	4 MINIMUM
101 TO 200 LBS	4"	6 MINIMUM
201 TO 250 LBS	3"	6 MINIMUM

"X" IS THE MAXIMUM LENGTH OF TRACK ALLOWED BEYOND END MOUNTING POINTS

STRUCTURAL BLOCKING DRILL PATTERN: (400LB MAX* PER TRACK)

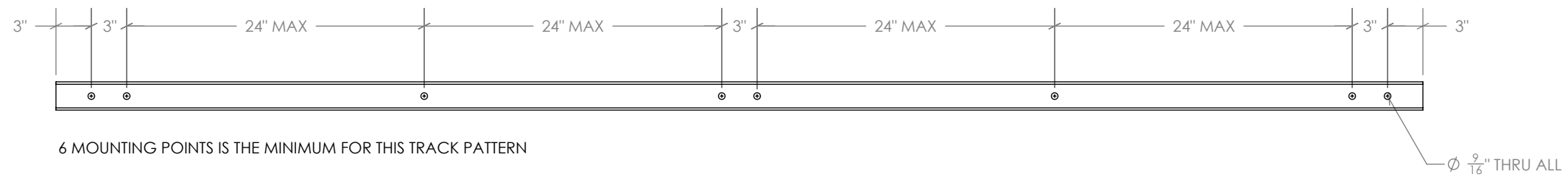



* WEIGHT LIMIT MAY BE FURTHER RESTRICTED BY TROLLEY SYSTEM

DOCUMENT:	PRODUCT SPECIFICATIONS - BYPASSING TRACK DRILL PATTERN GUIDE	DOOR APPLICATION:	BYPASSING	DRAWING SCALE:	1" = 1'-0" (1:12)	KROWNLAB 2351 NW York St. Portland, OR 97210 +1 503 292 6998 www.krownlab.com support@krownlab.com
SYSTEM:	TRU-LEVEL™ TRACK	PANEL THICKNESS:	TROLLEY SYSTEM OR BYPASSING DEPENDENT	UNITS:	INCHES	
MOUNTING STYLE:	FRAMED WALL	MAXIMUM WEIGHT:	TRACK CONFIGURATION, TRACK LENGTH OR TROLLEY SYSTEM DEPENDENT	DATE:	3/12/2018	

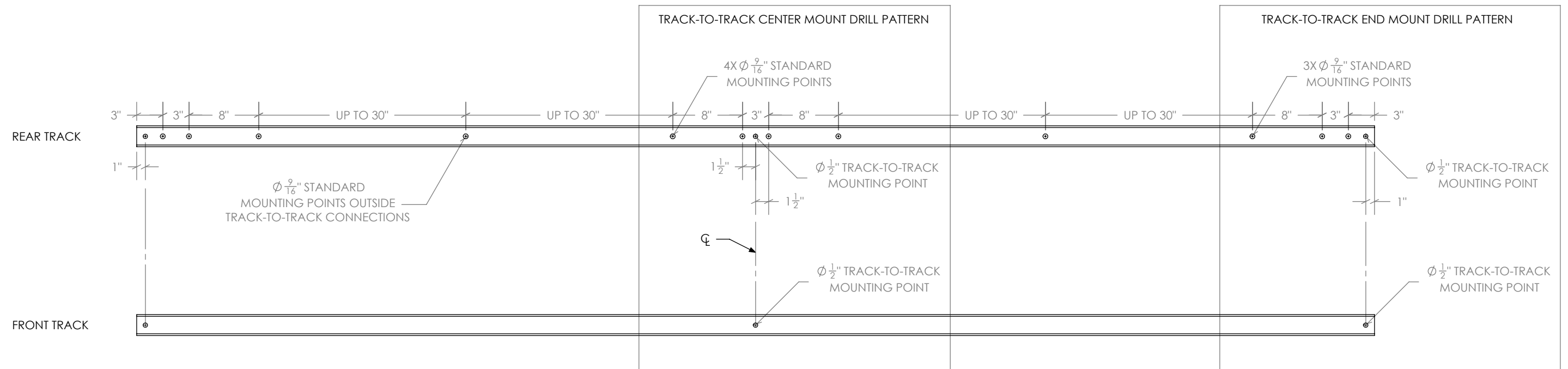

BYPASSING TRACKS ARE ONLY AVAILABLE MADE-TO-MEASURE.
 KROWNLAB WILL CONFIGURE THE FRONT AND REAR TRACKS USING THE RULES BELOW:



DOCUMENT:	PRODUCT SPECIFICATIONS - GLASS DOOR PANEL SPECIFICATIONS	DOOR APPLICATION:	SINGLE & BI-PARTING	DRAWING SCALE:	1" = 1'-0" (1:12)	KROWNLAB 2351 NW York St. Portland, OR 97210 +1 503 292 6998 www.krownlab.com support@krownlab.com	
SYSTEM:	TRU-LEVEL™ TRACK	PANEL THICKNESS:	3/8" TO 1/2" (CONTACT US FOR PANELS OUTSIDE OF THIS RANGE)	UNITS:	INCHES		
MOUNTING STYLE:	GLASS WALL	MAXIMUM WEIGHT:	TROLLEY SYSTEM OR TRACK CONFIGURATION DEPENDENT	DATE:	7/17/2019		

GLASS PANELS MUST BE FLAT POLISHED AND HAVE A 1MM CHAMFER ON ALL EDGES.

ALL HOLES MUST BE DRILLED OR CNC MACHINED WITH STRAIGHT WALLS AND SEAMED EDGES. DO NOT WATER-JET - NO TAPERED HOLES.

ALL TEMPERED GLASS IS SUBJECT TO EXPERIENCE SPONTANIOUS BREAKAGE. IT IS THE BUYERS RESPONSIBILITY TO DETERMINE AND APPROVE GLASS SPECIFICATION(S) SUITABLE TO MEET ALL FACTORS RELEVANT TO THEIR PARTICULAR USE OR APPLICATION IN CONJUNCTION WITH ALL KROWN LAB, INC.'S PRODUCTS.

REFERENCE ASTM C1048, 7.9.5

