

| | | | | | | | |
|-----------------|--|-------------------|---|----------------|---------------------|---|---|
| DOCUMENT: | PRODUCT SPECIFICATIONS - PREMIUM DOOR STOP | DOOR APPLICATION: | SINGLE*, BI-PARTING*, BYPASSING* | DRAWING SCALE: | 3/4" = 1'-0" (1:16) | KROWNLAB 2351 NW York St. Portland, OR 97210 +1 503 292 6998 www.krownlab.com support@krownlab.com |  PDX - ORE |
| SYSTEM: | TRU-LEVEL™ TRACK | PANEL THICKNESS: | TROLLEY SYSTEM OR TRACK CONFIGURATION DEPENDENT | UNITS: | INCHES | | |
| MOUNTING STYLE: | TOP MOUNT, FACE MOUNT, GLASS MOUNT | MAXIMUM WEIGHT: | TROLLEY SYSTEM OR TRACK CONFIGURATION DEPENDENT | DATE: | 10/9/2018 | | |

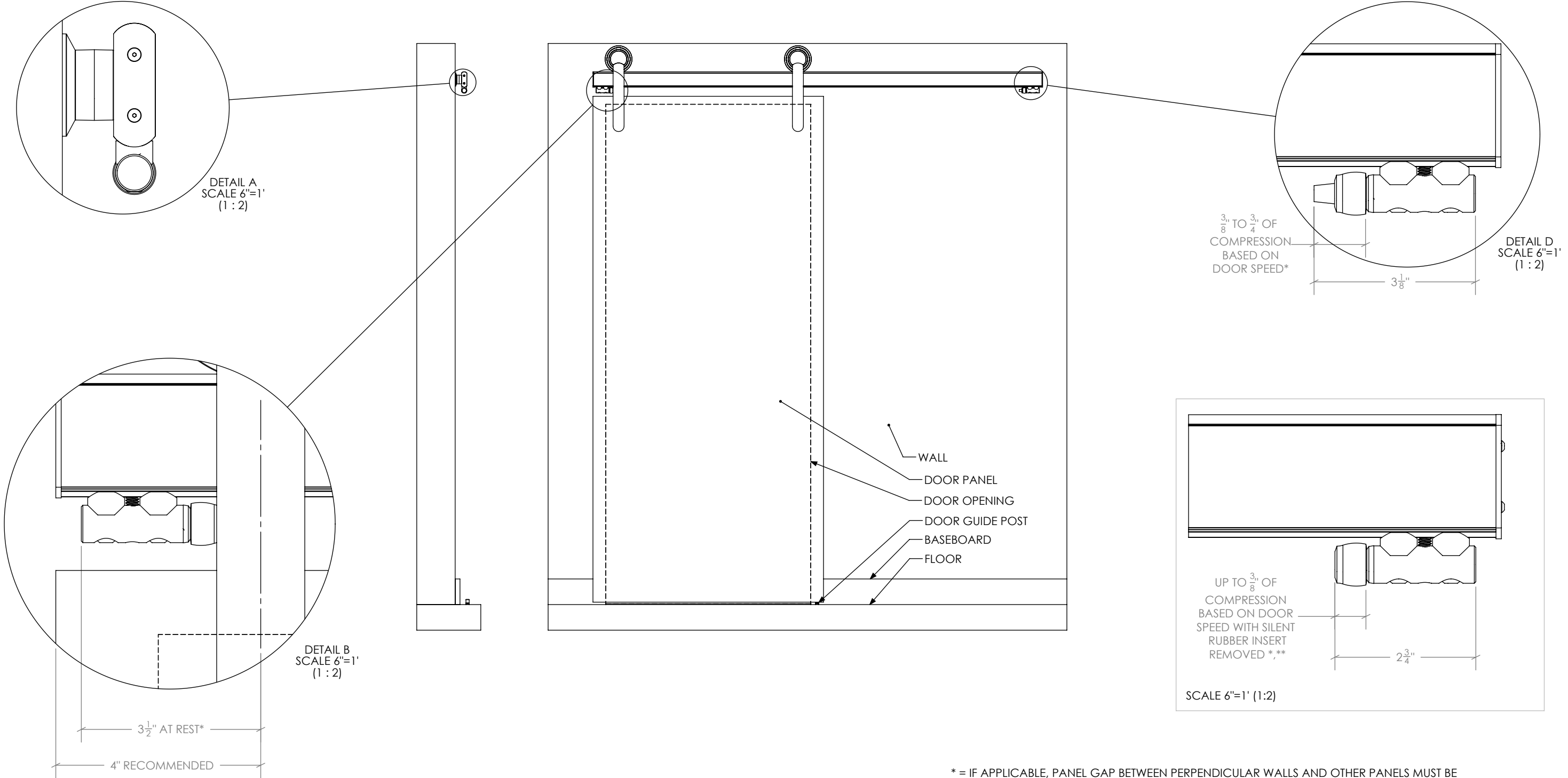

* = IF APPLICABLE, PANEL GAP BETWEEN PERPENDICULAR WALLS AND OTHER PANELS MUST BE INCREASED TO AVOID COLLISION. DOOR TRAVEL INCREASES BASED ON SPEED AND COMPRESSION OF PREMIUM DOOR STOP.

** = REMOVING SILENT RUBBER INSERT WILL REMOVE THE SILENT FEATURE, BUT MAY BE A NECESSARY ADJUSTMENT TO REDUCE POSSIBLE EXTRA DOOR TRAVEL. THE ENERGY ABSORBING FEATURE OF THE PREMIUM DOOR STOP WILL REMAIN IN THIS CONFIGURATION.