

RAGNAR + ODEN

GLASS MOUNT, BYPASSING

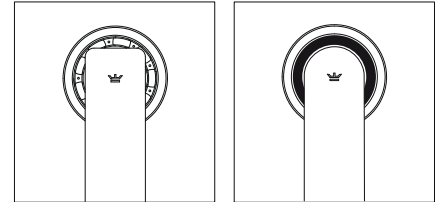

I. VERIFY ALL COMPONENTS

BASE KIT

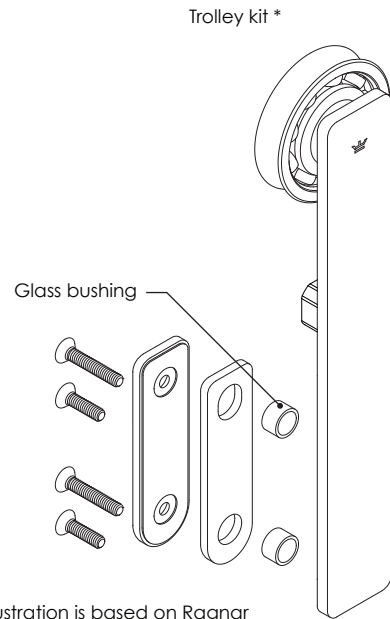
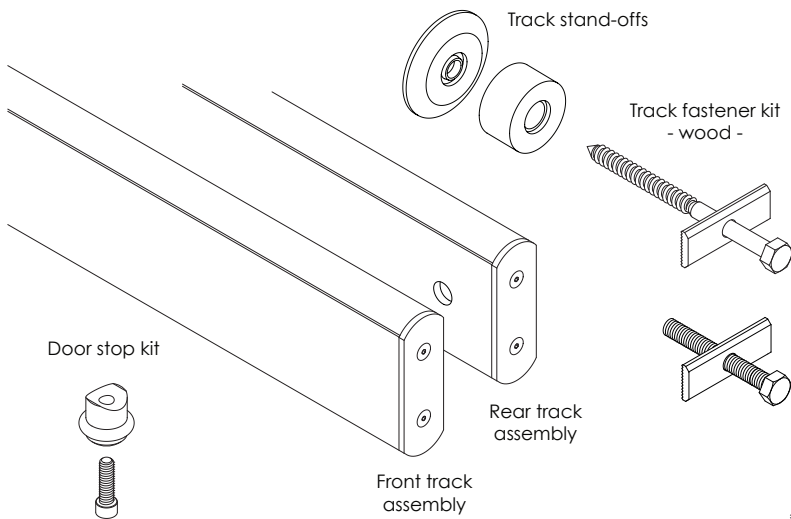

SYSTEM OPTIONS AND ADDITIONS

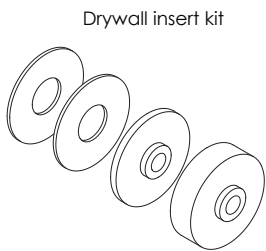

Drywall insert kit



Track fastener kit
- concrete -

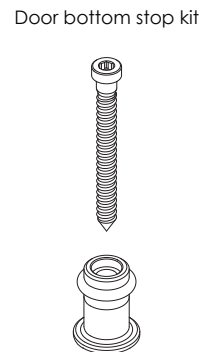

Door bottom stop kit

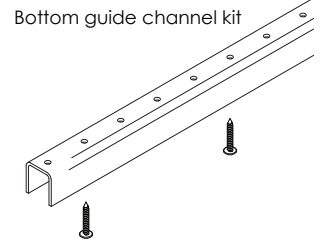

Bottom guide channel kit

Track shim kit

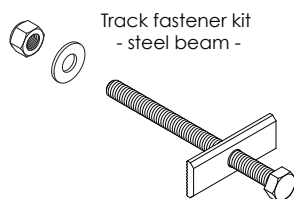

Track fastener kit
- steel beam -

2. REMOVE TRACK COVERS

- ① Remove the track from the protective sleeves.
- ② Gently pry the cover from the base of the rear track assembly with a slender plastic (non-marring) tool.

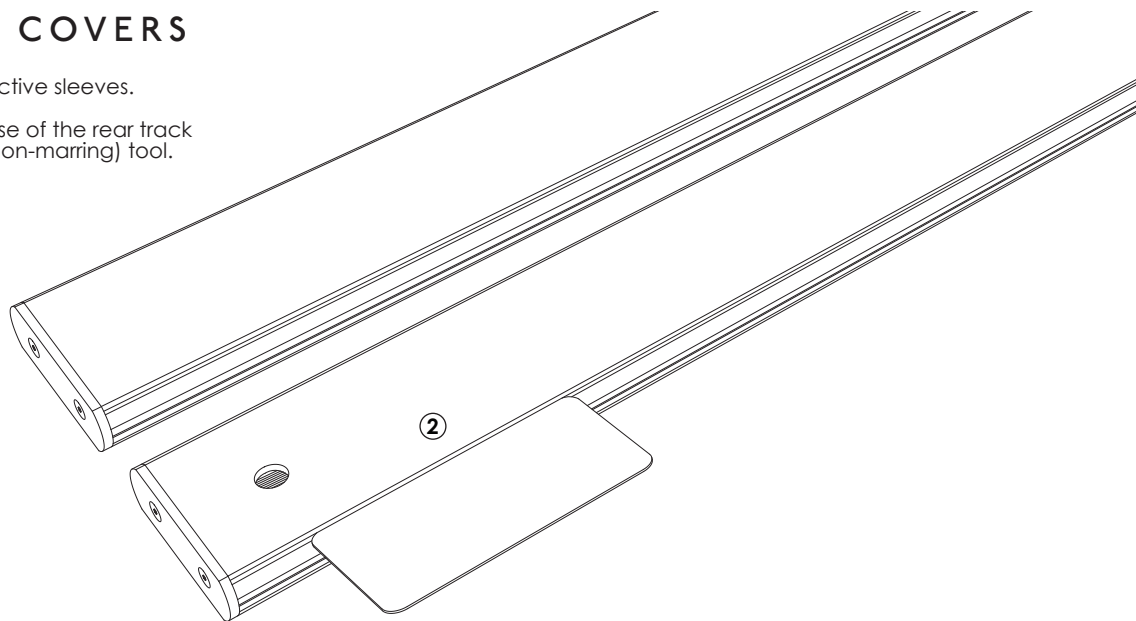

3. LOCATE TRACK ATTACHMENT POINTS

- ① Determine the height of the track:
 $\text{HEIGHT} = \text{DOOR PANEL HEIGHT} + 2\text{-}7/8\text{'}$
This provides a clearance for the included glass bottom guide.
- ② Mark the centerline of the track mounting holes on your wall. (If you run a length of painter's tape along the length of your wall, you'll thank us later!)
- ③ On the wall, mark the middle of the opening. This will be where the track is centered.
- ④ Determine and mark the locations of all mounting points along the track centerline.

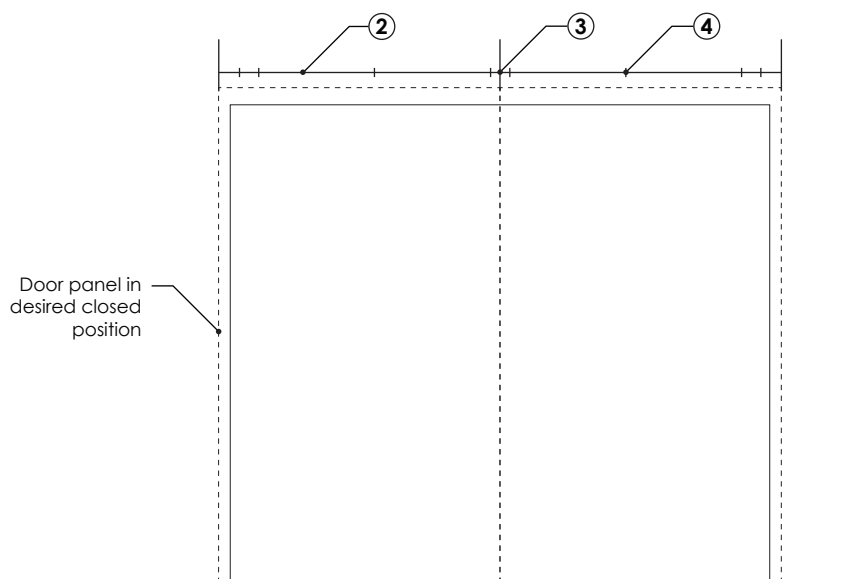

4. OPTIONAL STEP - INSTALL DRYWALL INSERTS

Required for high use installations and doors in excess of 200 lbs combined weight.

- ① Use a 1-3/4" spade or Forstner bit to remove the drywall at each mounting point.
 - ② Place a drywall insert into each drywall cavity.
- ⚠ To perform their function, drywall inserts must be up against the structural material of your wall and flush with the finished surface of the drywall. If needed, use the included steel shims as shown.

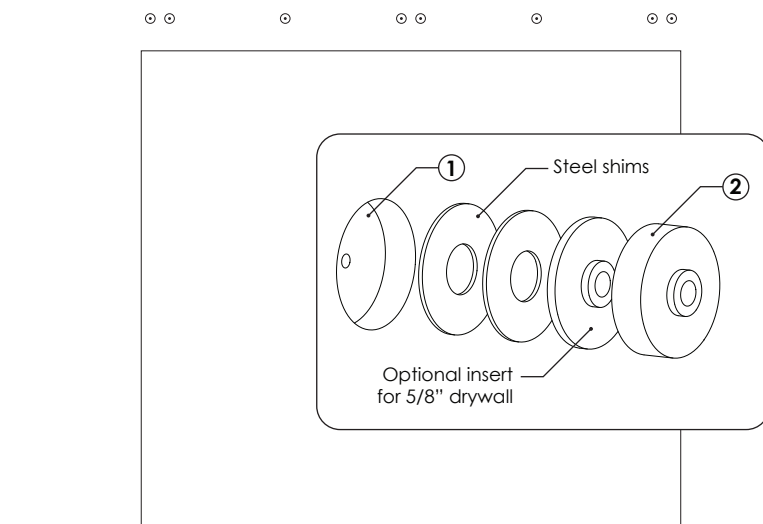

5. PREPARE WALL

- ① Drill a pilot hole for each mounting point.
- ❗ Make sure that each mounting point engages an appropriate amount of structural material:
 - A. Wood or metal stud framed walls must have 3" of solid wood blocking secured to studs or other framing members.
 - B. Concrete and masonry walls must be solid and thicker than the minimum required thread engagement of 1-1/2".
 - C. Steel beams must be structural in nature and have a minimum wall thickness of 1/4". Note that you cannot attach this hardware to sheet metal studs.

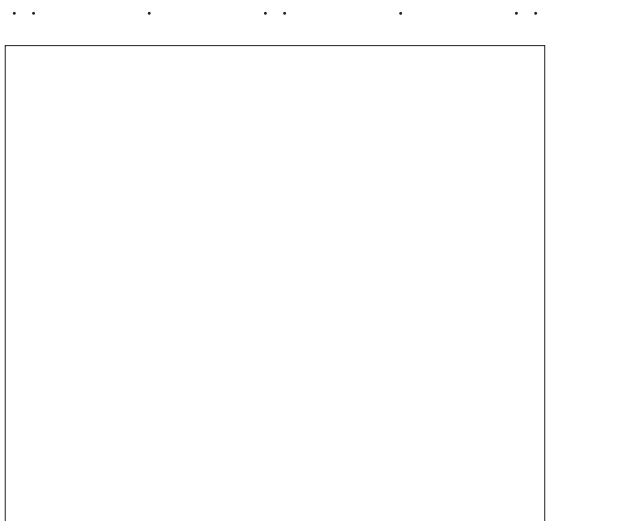

6. DETERMINE DESIRED WALL CLEARANCE

- ① Determine if you need to use the optional panel spacer based on panel thickness and base board.

Desired clearance	Required 1/4" track stand-off	Optional 3/4" track stand-off	Optional panel spacer
1"	√		√
1-1/4"	√		
1-3/4"	√	√	√
2"	√	√	

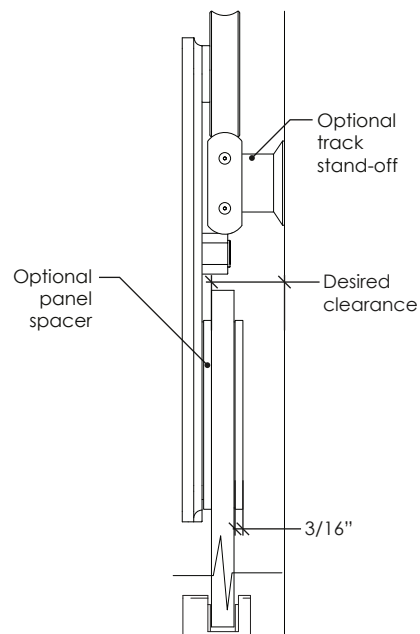

7. MOUNT REAR TRACK TO WALL

- ① Ensuring that the black plastic track cap faces up, loosely install one end of your track with the appropriate track spacers and hardware.
- ② Repeat with the opposite end of the track.
- ③ With both ends of the track now supported, loosely install the remaining mounting points.

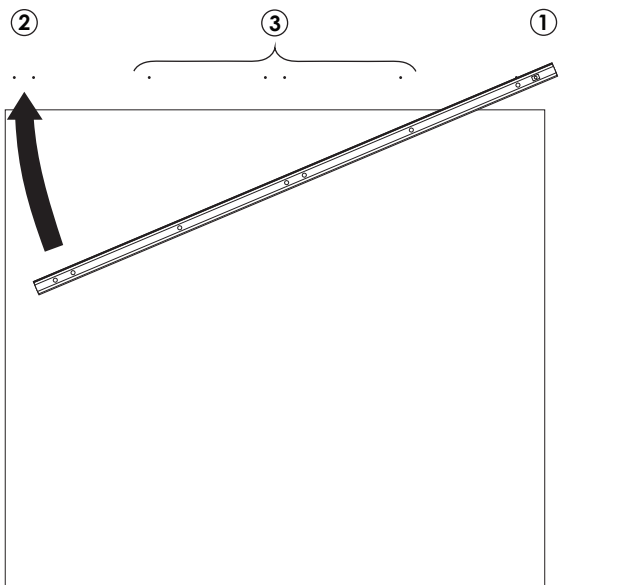
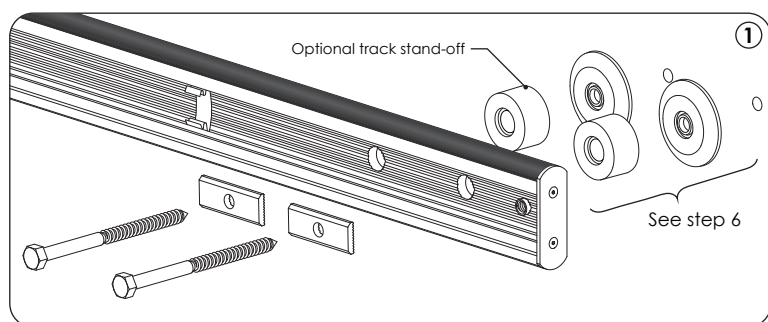

8. ADJUST REAR TRACK HEIGHT

- ① Tighten each track fastener, starting at the center and moving toward the ends. For maximum adjustability, start by positioning the washer plate in the center (neutral) position.
- ⚠ Be sure to account for sloped or uneven floor when setting track height.
- ② Use the Tru-Level™ System to make sure track is level: adjust the position of the washer plate at each mounting point until track is level.
- ⚠ Ensure that washer teeth align with teeth in the track before tightening fasteners.

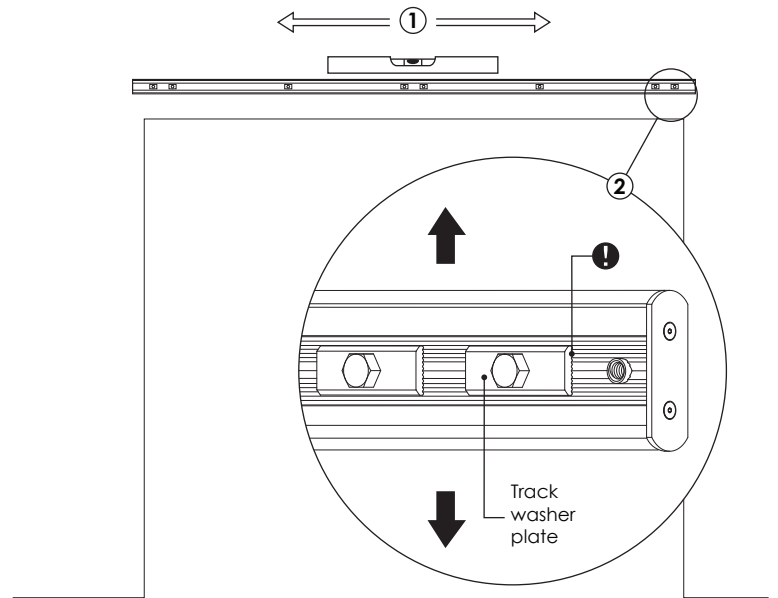

9. OPTIONAL STEP - INSTALL TRACK SHIMS

- ① Sight down the length of your track to determine if unevenness in the wall is causing your track to bow. If necessary:
- ② Loosen track attachment points as needed and insert shims from below. Ensure that the opening of the shim faces up. Start with one of the thinner shims, adding and swapping shims as needed until the track is straight to within the thickness of one shim.
- ⚠ If optional track stand-offs are installed, do not use more than one shim kit per mounting point.

NOTE: Bowing in the track will negatively affect the performance of the entire system, causing increased friction and excessive wear on some components. Krownlab's warranty does not cover wear caused by improper installation.

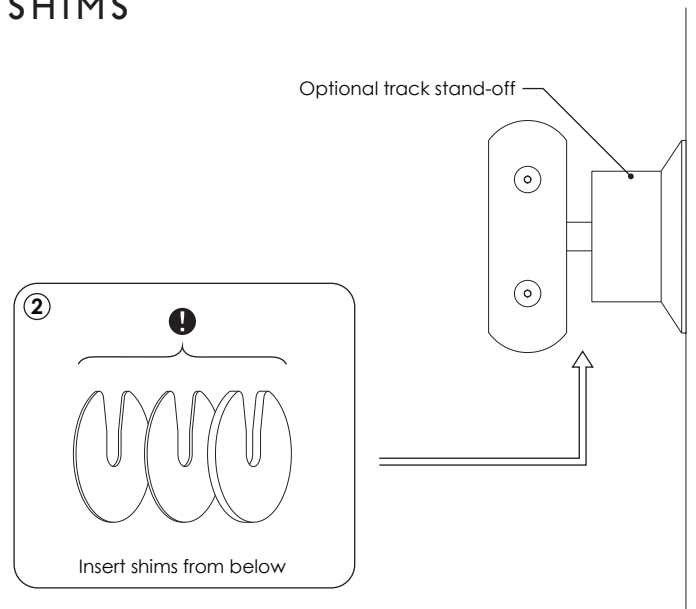

10. ATTACH REAR TRACK COVER

- ① After the rear track has been leveled, shimmed, and all mounting points have been securely fastened to 120 inch-lbs (10 ft-lbs) with appropriate torque wrench, reattach the rear track cover.
- ⚠ Ensure that the arrow on the inside of the track cover is facing up.
- ⚠ Ensure that rear track cover is used.

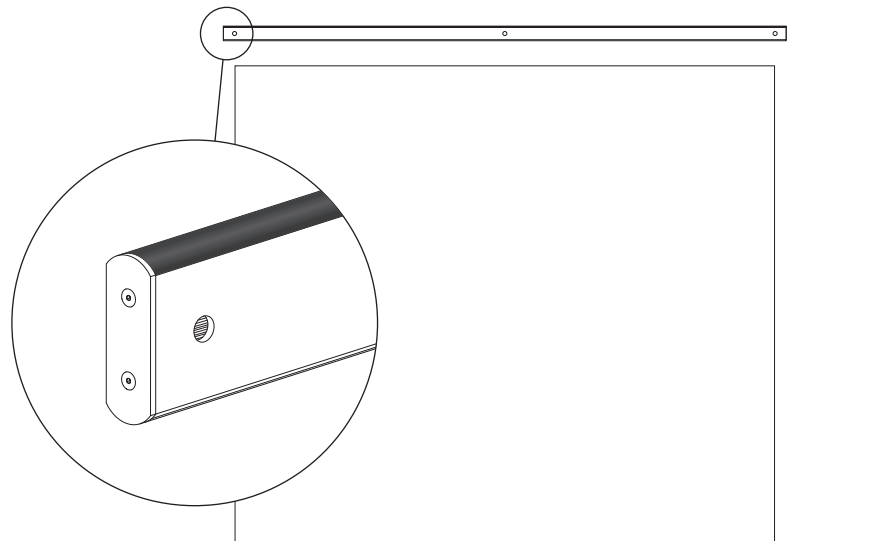
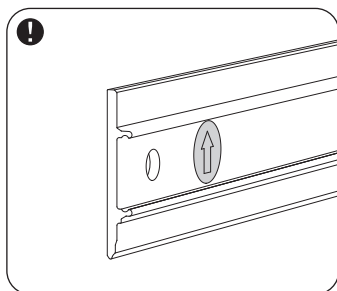

11. ATTACH DOOR STOPS

- 1 Locate the preinstalled nuts in the bottom of the track. Loosely screw a door stop to each nut.
- 2 Temporarily slide one door stop to each end of the track. Do not tighten the stops until step 24.

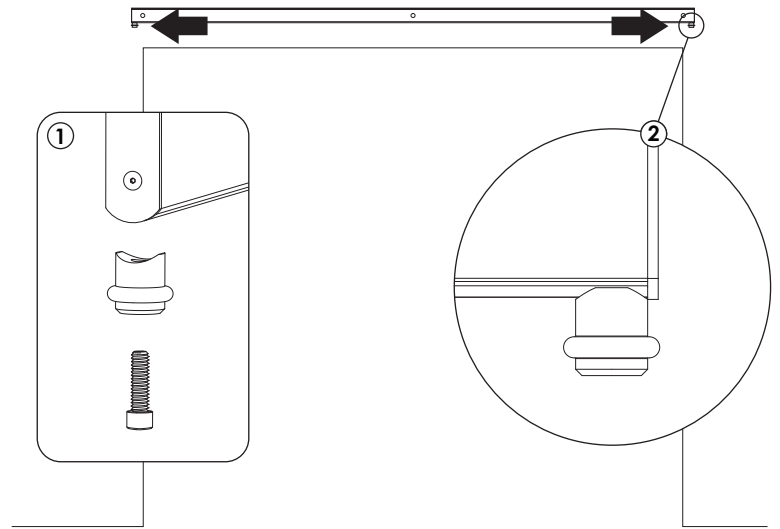

12. VERIFY DOOR PANEL SPECIFICATIONS

- 1 Ensure the glass door panel has the correct hole placement, hole sizing, and is prepared per Krownlab's Glass Panel Specs document (located at www.krownlab.com/downloads)
- 2 Inspect glass for any defects, e.g. chips, deformations, or irregularly shaped holes.



Do not use glass with any defects!!!! Any defect is a safety hazard and must be replaced.

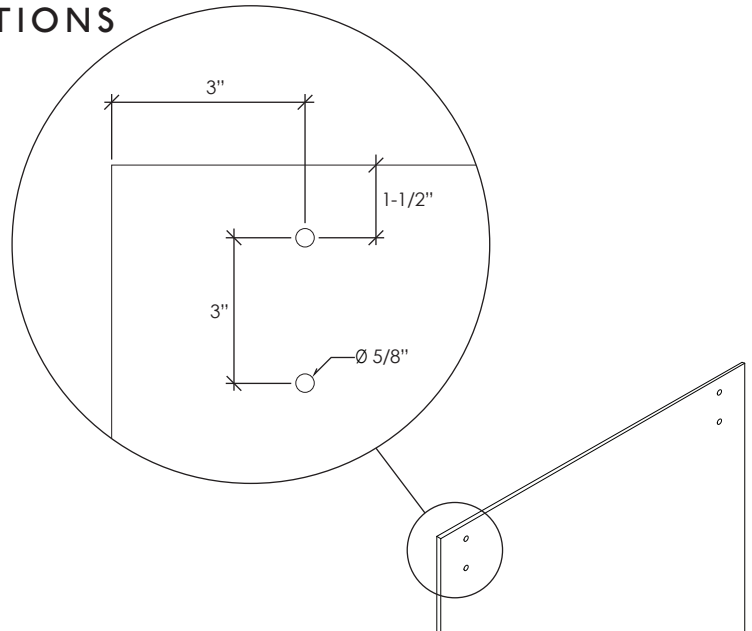

13. ATTACH TROLLEYS TO DOOR PANEL

- 1 Attach the trolleys using the correct length fastener as shown in the table below.
 - 2 Gently tighten, then back out each screw a half turn. This will allow you to adjust the panel height after installation.
 - 3 Remove the trolley stops with provided 9" wrench. Note how tight the screws are. You will need to tighten the screws to this same tension when the trolley stops are reinstalled.
 - 4 Carefully hang your panel.
- ⚠ Do not yet install your door pulls or other door hardware.

Optional panel spacer	Correct screw lengths			
	3/8" panel	1/2" panel	5/8" panel	3/4" panel
	3/4"	3/4"	1"	1"
√	1"	1"	1-1/4" *	1-1/4" *

*Bagged with bottom guide

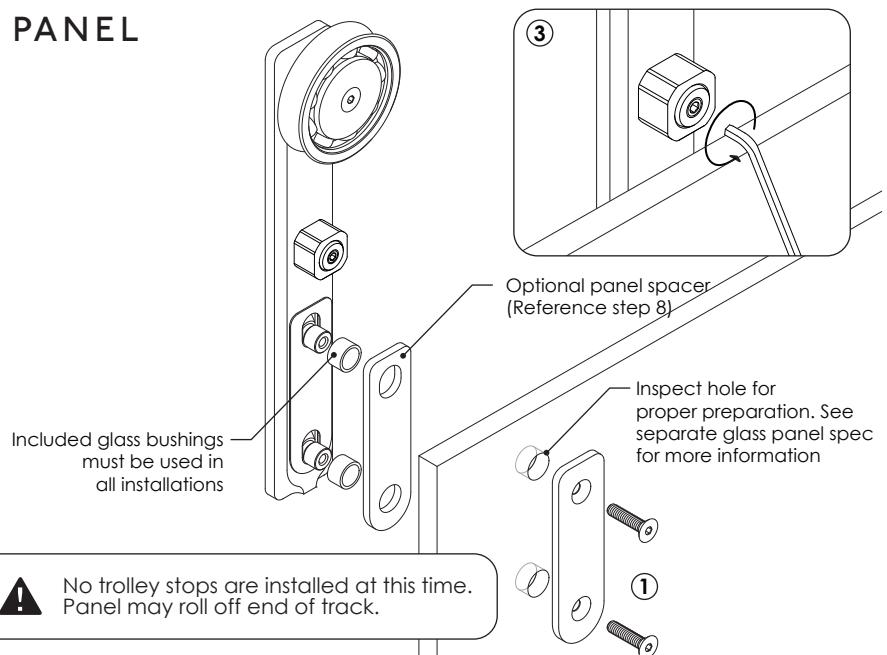

No trolley stops are installed at this time. Panel may roll off end of track.

14. REATTACH TROLLEY STOPS FOR REAR PANEL

- 1 Place the correct trolley stop assembly on the back of the trolley.
 - 2 Align interlocking features and fully seat the trolley stop. Note that a properly seated trolley stop will have interlocking features fully engaged and you will not be able to twist it.
 - 3 Thread and tighten the trolley stop screw using your fingers until finger-tight.
 - 4 Repeat above steps for second trolley
- ⚠ Do not tighten the trolley stops all the way yet.

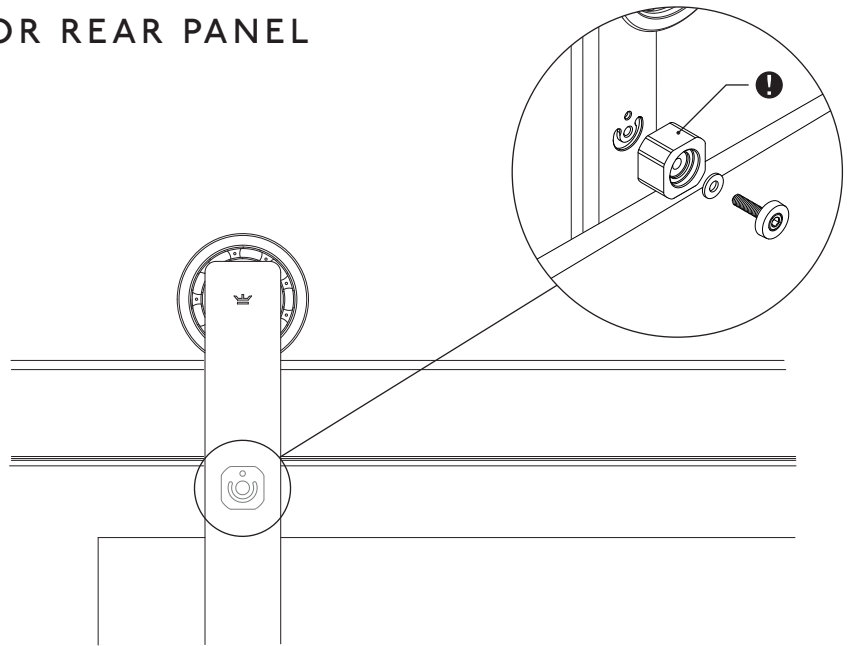

15. ADJUST REAR PANEL HEIGHT

- 1 Visually check for any interference due to an uneven, sloped or irregular floor.
 - 2 If necessary, adjust the height of the panel by tightening the screws at the bottom of each trolley.
 - 3 After the panel height has been adjusted, tighten the trolley screws to 108 inch-lbs (9 ft-lbs) with appropriate torque wrench on the back side of the panel.
- ⚠ If additional vertical adjustment is required, unhang the door panel, remove the track cover, and adjust the track up or down as needed.

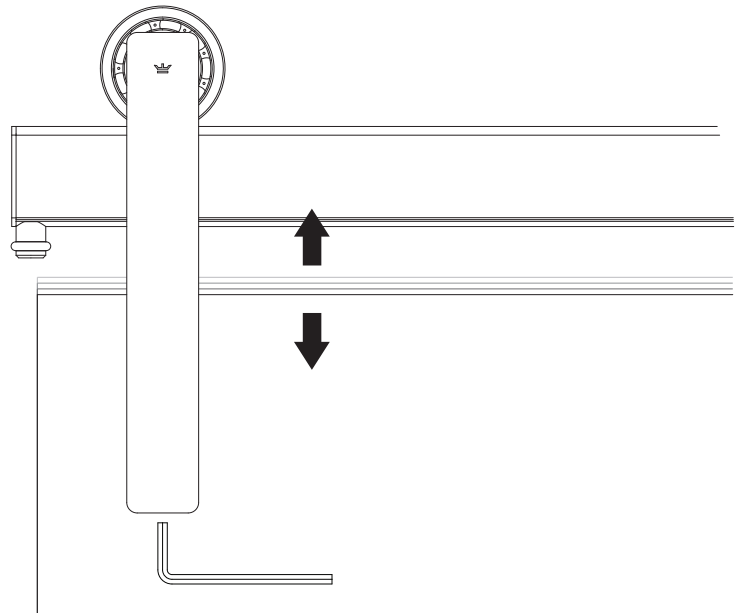

16. PREPARE REAR GLASS BOTTOM GUIDE

- 1 Remove adjustment cover from the underside of bottom guide, and position adjustment plate to fit your door panel thickness and reattach the adjustment cover.
- ⚠ If your door panel is 5/8" or 3/4" thick, you will have received a bottom guide for your specific thickness.
- 2 Mark door panel plumb line on floor.
 - 3 Remove door (if needed), and mark intersection of center of door opening and door panel plumb line.

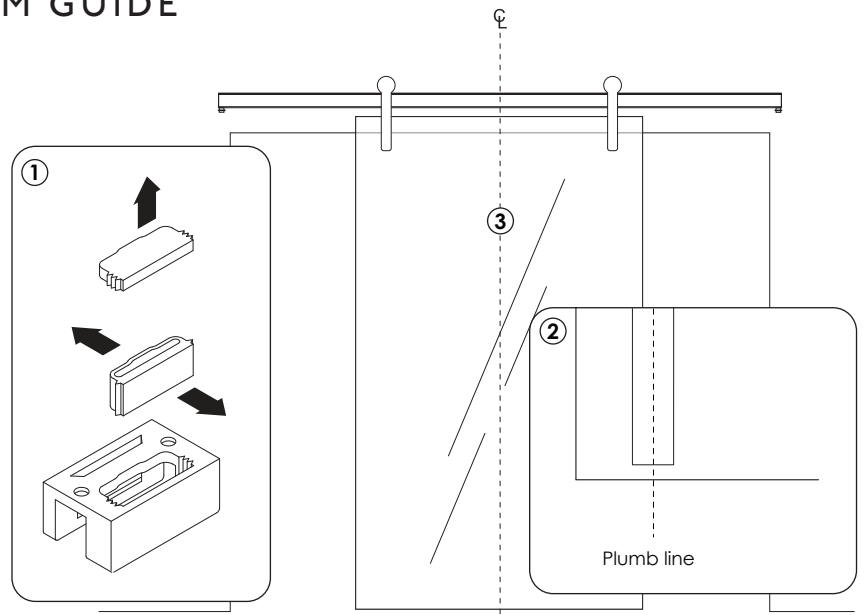

17. INSTALL REAR GLASS BOTTOM GUIDE

- ① Pre-drill and install glass bottom guide as shown, with the adjustment plate facing away from the wall.
- ② Rehang door.

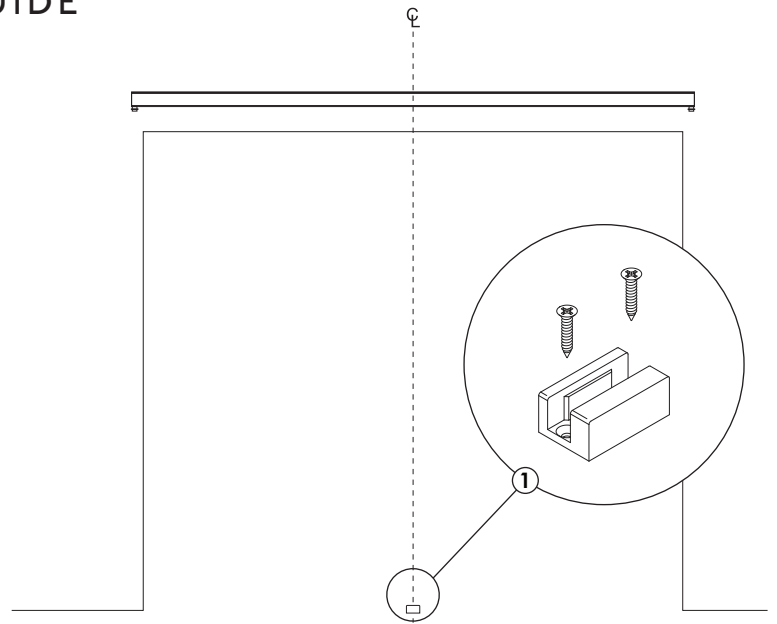

18. REINSTALL TROLLEY STOPS FOR REAR PANEL

- ① Repeat step 14 from 1 to 3 to set trolley stops in place.
 - ② Once finger-tight, you will have enough room to fit the wrench. Protect wall with blue tape to prevent scraping with wrench.
 - ③ Slide the provided 9" wrench behind the track and firmly tighten the screw to 48 inch-lbs (4 ft-lbs). Please note this is the same tightness the screw had when it arrived.
 - ④ Repeat above steps for second trolley
- ⚠ In some instances, the screw may also be accessed from inside the door opening. This may aid installation.

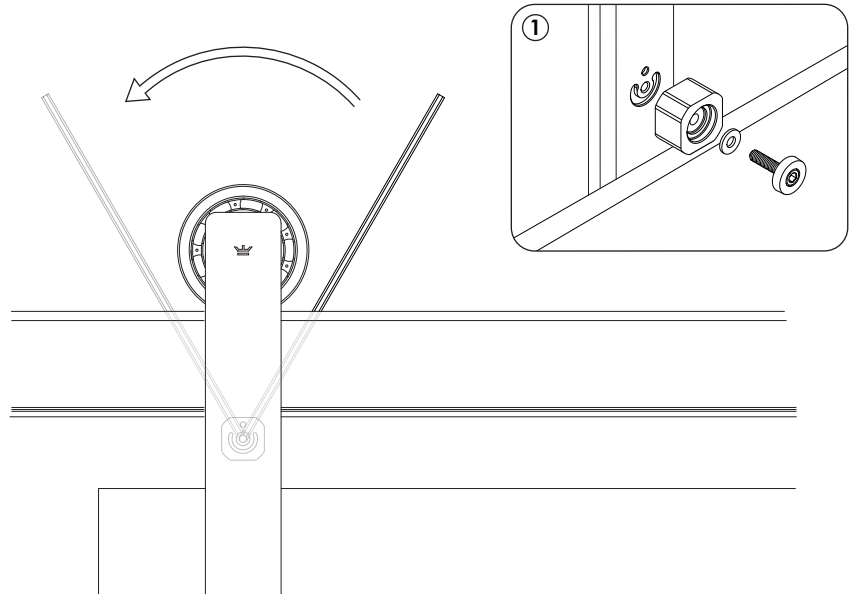

19. MOUNT FRONT TRACK TO WALL

- ① Ensuring that the black plastic track cap faces up, loosely install one end of your track with the supplied track spacers and hardware.
- ② Repeat with the opposite end of the track.
- ③ With both ends of the track now supported, loosely install the middle mounting point.

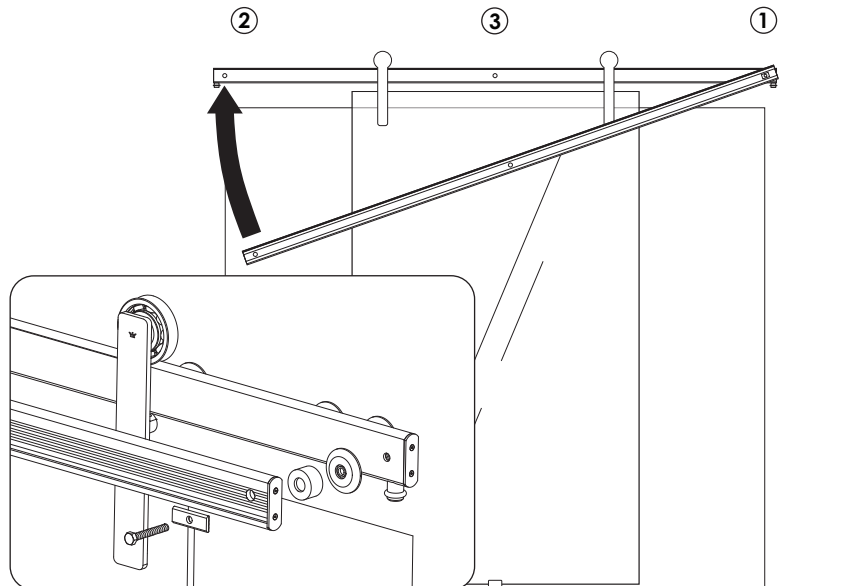

20. ADJUST FRONT TRACK HEIGHT

- 1 Tighten each track fastener starting at the center. For maximum adjustability, start by positioning the washer plate in the center (neutral) position.
- 2 Use the Tru-Level™ System to make sure track is level: adjust the position of the washer plate at each mounting point until track is level.
- ! Ensure that washer teeth align with teeth in the track before tightening fasteners.
- ! Ensure front track is level with the rear track

NOTE: A 9/16" wrench can be used to hold the nut insert from rotating.

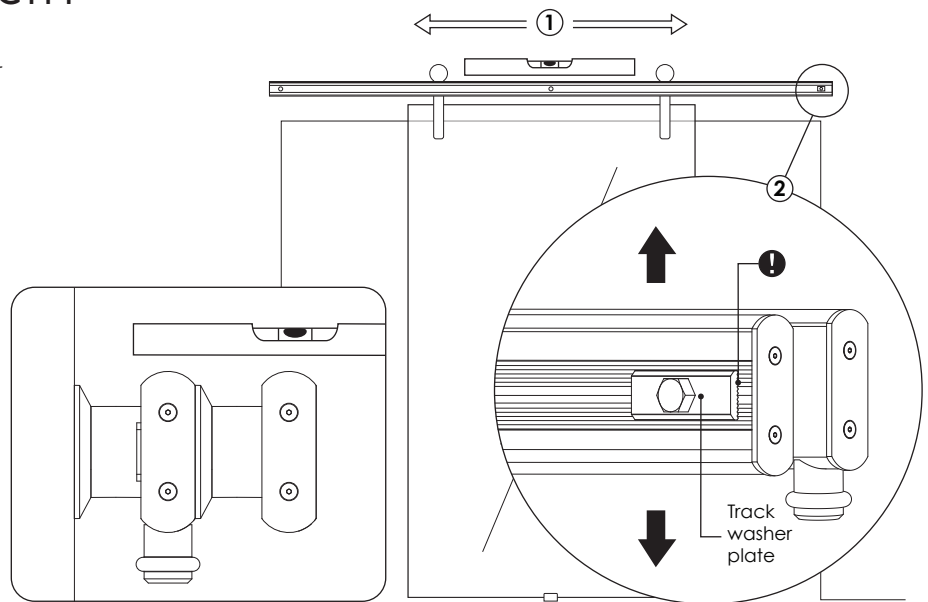

21. ATTACH FRONT TRACK COVER

- 1 After the front track has been leveled and all mounting points have been securely fastened to 120 inch-lbs (10 ft-lbs) with appropriate torque wrench, reattach the track cover.
- ! Ensure that the arrow on the inside of the front track cover is facing up.

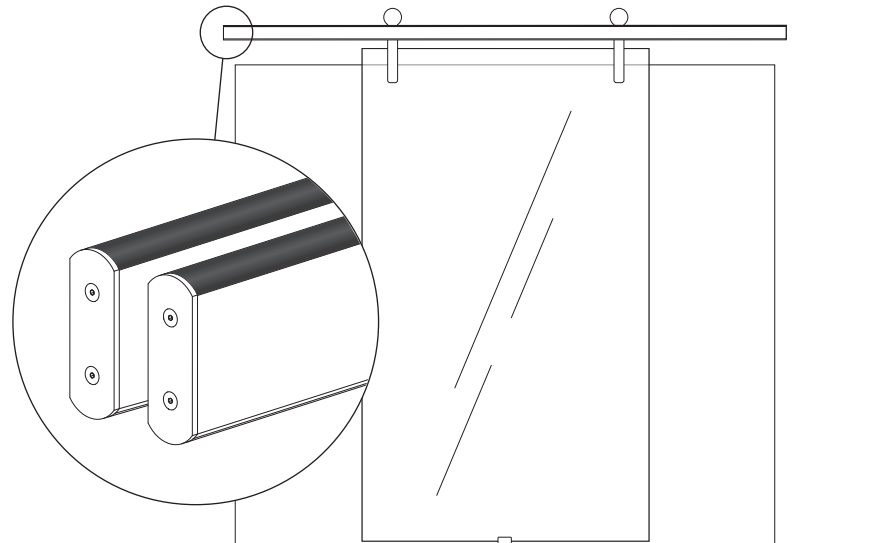
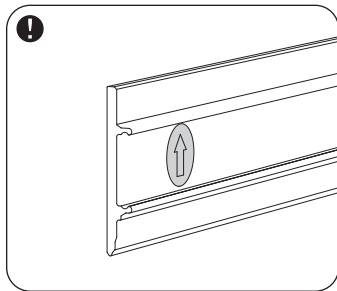

22. ATTACH DOOR STOPS

- 1 Locate the preinstalled nuts in the bottom of the tracks. Loosely screw a door stop to each nut.
- 2 Temporarily slide one door stop to each end of the track. Do not tighten the stops until step 28.

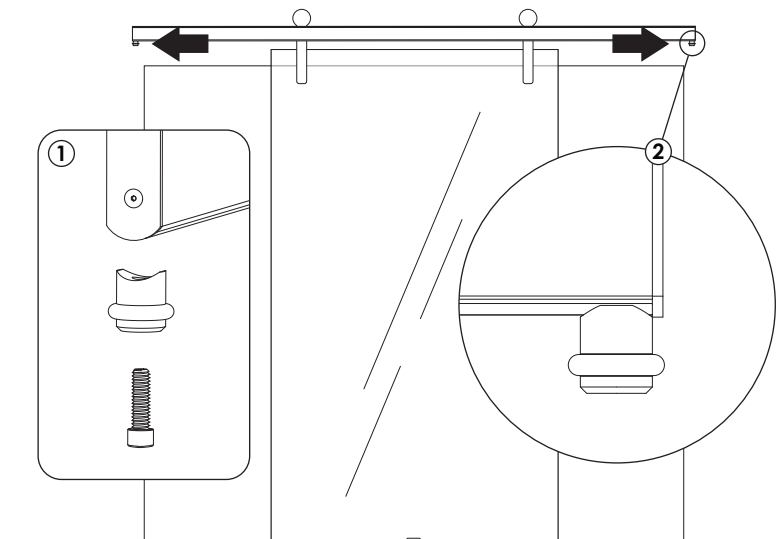

23. REATTACH TROLLEY STOPS FOR FRONT PANEL

- ① Hang front door panel.
- ② Place the correct trolley stop assembly on the back of the trolley.
- ⚠ Use longer trolley stops for front panel.
- ③ Align interlocking features and fully seat the trolley stop. Note that a properly seated trolley stop will have interlocking features fully engaged and you will not be able to twist it.
- ④ Thread and tighten the trolley stop screw using your fingers until finger-tight.
- ⑤ Repeat above steps for second trolley
- ⚠ Do not tighten the trolley stops all the way yet.

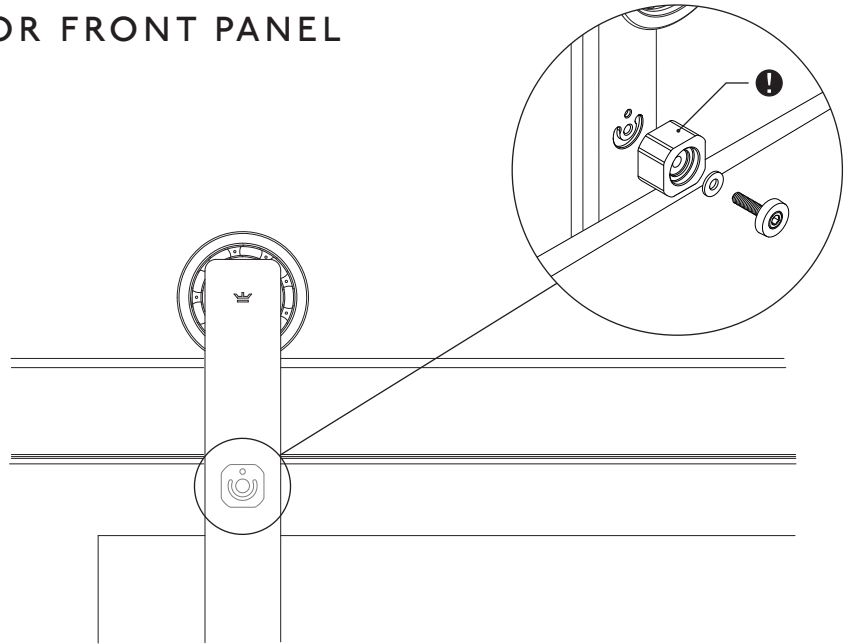

24. ADJUST FRONT PANEL HEIGHT

- ① Visually check for any interference due to an uneven, sloped or irregular floor.
- ② If necessary, adjust the height of the panel by tightening the screws at the bottom of each trolley.
- ③ After the panel height has been adjusted, tighten the trolley screws to 108 inch-lbs (9 ft-lbs) with appropriate torque wrench on the back side of the panel.
- ⚠ If additional vertical adjustment is required, unhang the door panel, remove the track cover, and adjust the track up or down as needed.

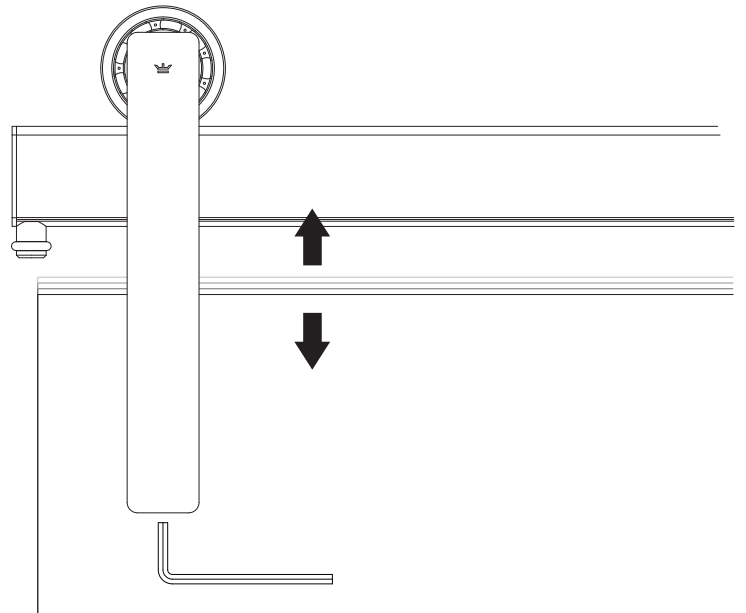

25. PREPARE FRONT GLASS BOTTOM GUIDE

- ① Remove adjustment cover from the underside of bottom guide, and position adjustment plate to fit your door panel thickness and reattach the adjustment cover.
- ⚠ If your door panel is 5/8" or 3/4" thick, you will have received a bottom guide for your specific thickness.
- ② Mark front door panel plumb line on floor.
- ③ Remove door (if needed), and mark intersection of center of door opening and door panel plumb line.

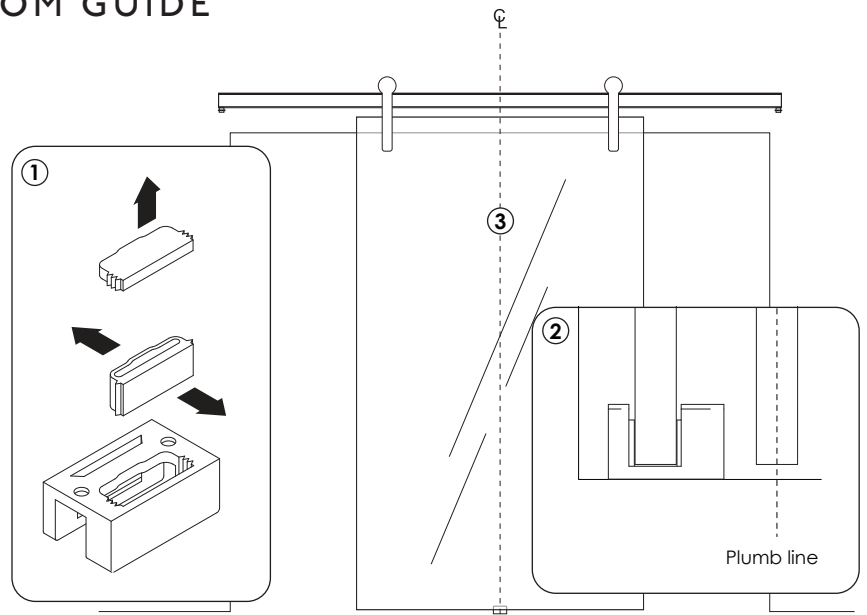

26. INSTALL FRONT GLASS BOTTOM GUIDE

- ① Pre-drill and install glass bottom guide as shown, with the adjustment plate facing away from the wall.
- ② Rehang door.

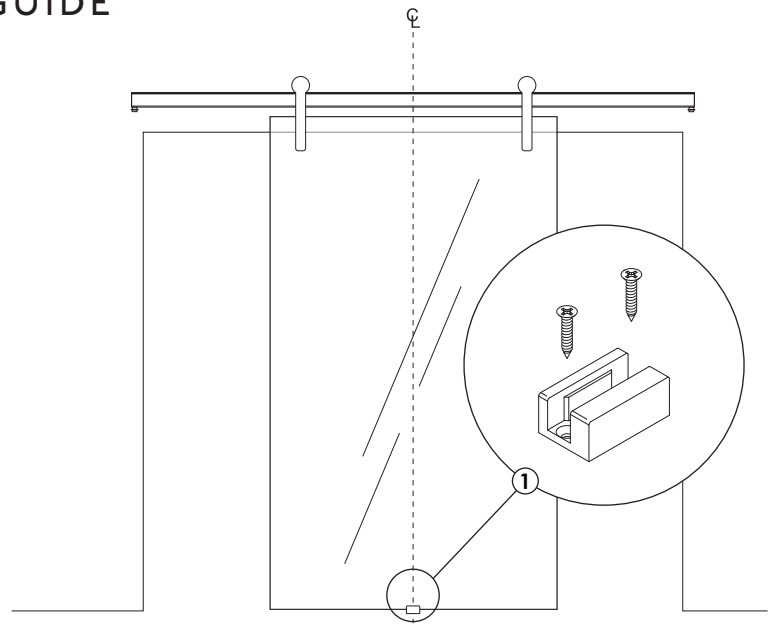

27. REINSTALL TROLLEY STOPS FOR FRONT PANEL

- ① Repeat step 23 from 1 to 3 to set trolley stops in place.
 - ② Once finger-tight, you will have enough room to fit the wrench. Protect wall with blue tape to prevent scraping with wrench.
 - ③ Slide the provided 9" wrench behind the track and firmly tighten the screw to 48 inch-lbs (4 ft-lbs). Please note this is the same tightness the screw had when it arrived.
 - ④ Repeat above steps for second trolley
- ⚠ In some instances, the screw may also be accessed from inside the door opening. This may aid installation.

Note: Please keep the 9" wrench to make it easier to your sliding door.

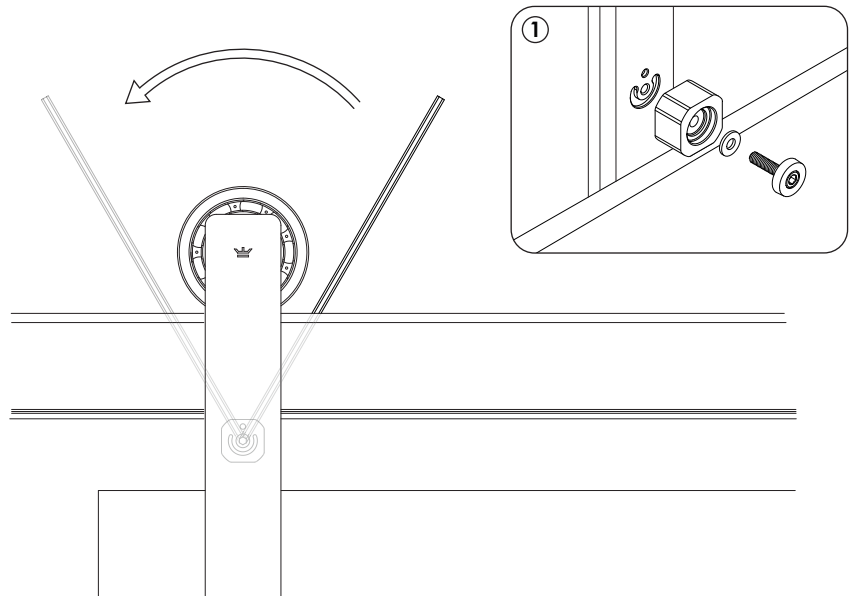

28. POSITION DOOR STOPS

- ① With both doors in the desired closed position, slide the door stops so that they touch the safety stop of the trailing trolley. Tighten the door stop in place to 108 inch-lbs (9 ft-lbs) with appropriate torque wrench.
 - ② Repeat with the doors in the opposite desired closed positions.
- ⚠ Verify that the glass bottom guides are properly engaged in the fully open and fully closed positions.

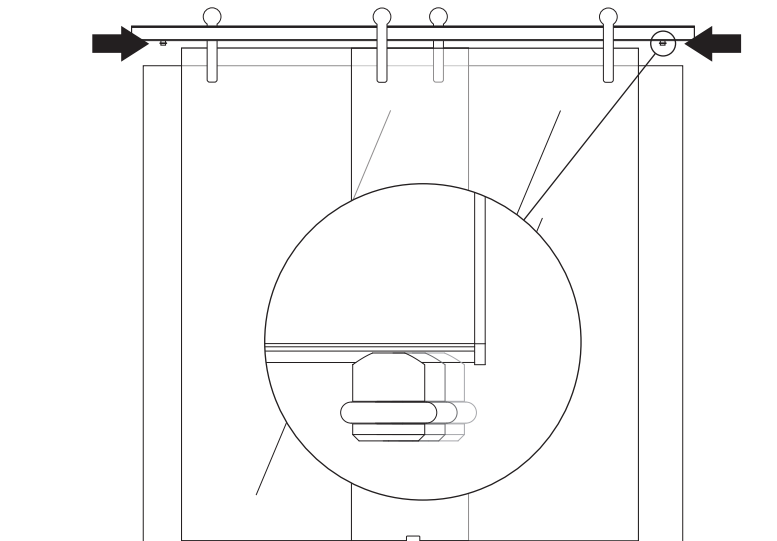

29. PRODUCT CARE

Common Parts

Wheels (bearings) should occasionally be lubricated with bearing oil (e.g. SHC 630 Synthetic Gear and Bearing Oil by Exxon Mobil Corp: www.mobil.com).

Brushed Stainless

To clean any time after installation, use a non-abrasive lint free cloth or sponge and household glass cleaner. (Remember to test an inconspicuous area prior to cleaning hardware.) Do not use steel wool, or a Scotch Brite pad, as it can scratch the product.

Black Stainless

To enhance the depth and shine of the finish, periodically apply a thin coating of petroleum jelly with a clean cloth, buff clean and dry. Do not use steel wool, or a Scotch Brite pad, as it can scratch the product.

Product may be covered by pending and awarded U.S. patents. For more information visit www.krownlab.com
