

### RAGNAR+ODEN

#### TOP MOUNT, SINGLE

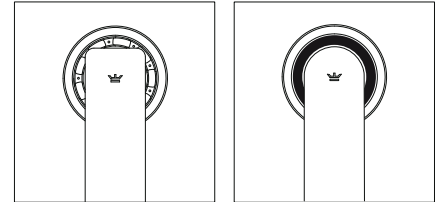

## I. VERIFY ALL COMPONENTS

### BASE KIT

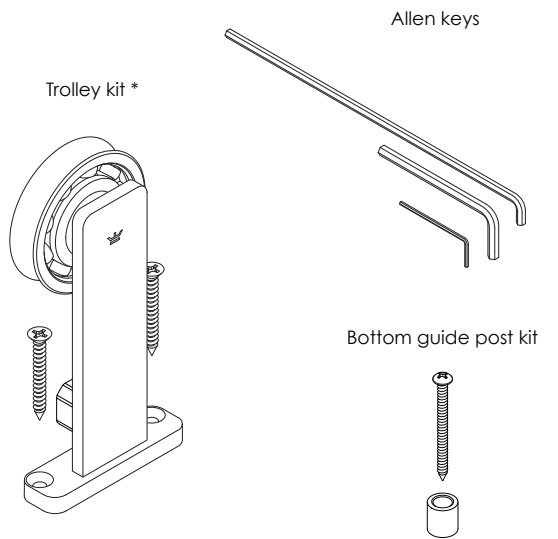
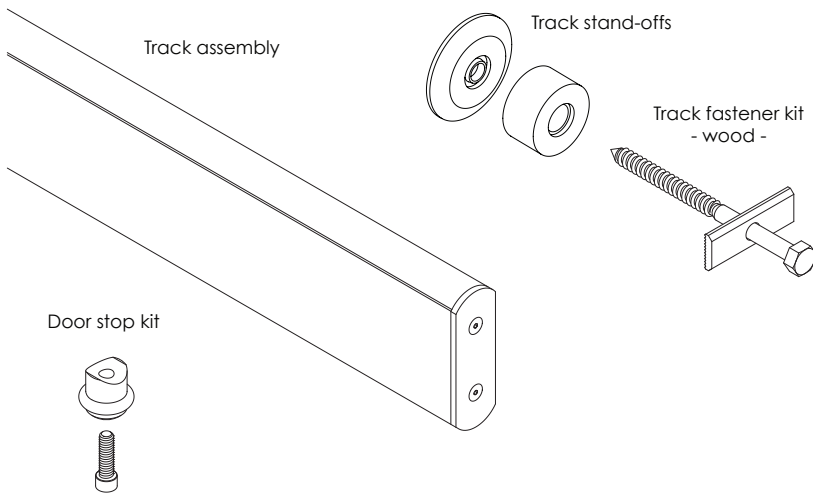

\* Illustration is based on Ragnar

## SYSTEM OPTIONS AND ADDITIONS

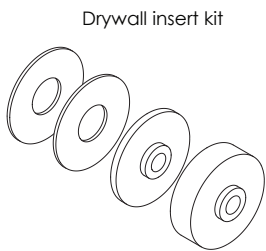

Drywall insert kit



Track fastener kit  
- concrete -

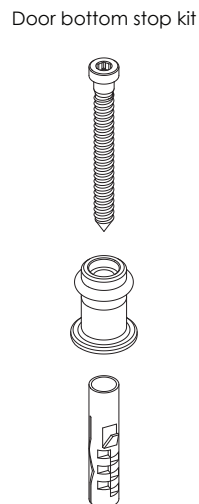

Door bottom stop kit

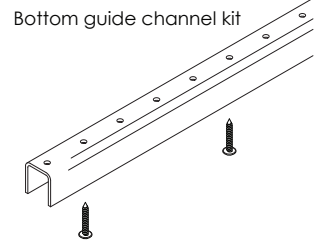

Bottom guide channel kit



Track shim kit

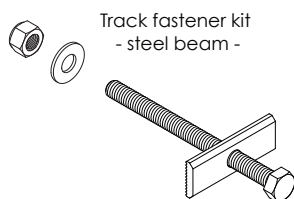

Track fastener kit  
- steel beam -

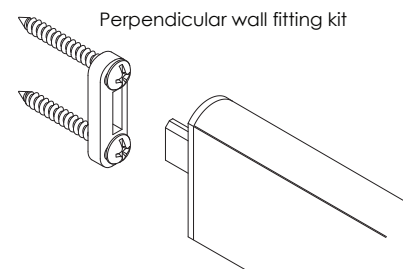

Perpendicular wall fitting kit

## 2. REMOVE TRACK COVER

- ① Remove the track from the protective sleeve.
- ② Using a credit card or other non-metal object, gently pry the cover from the base.

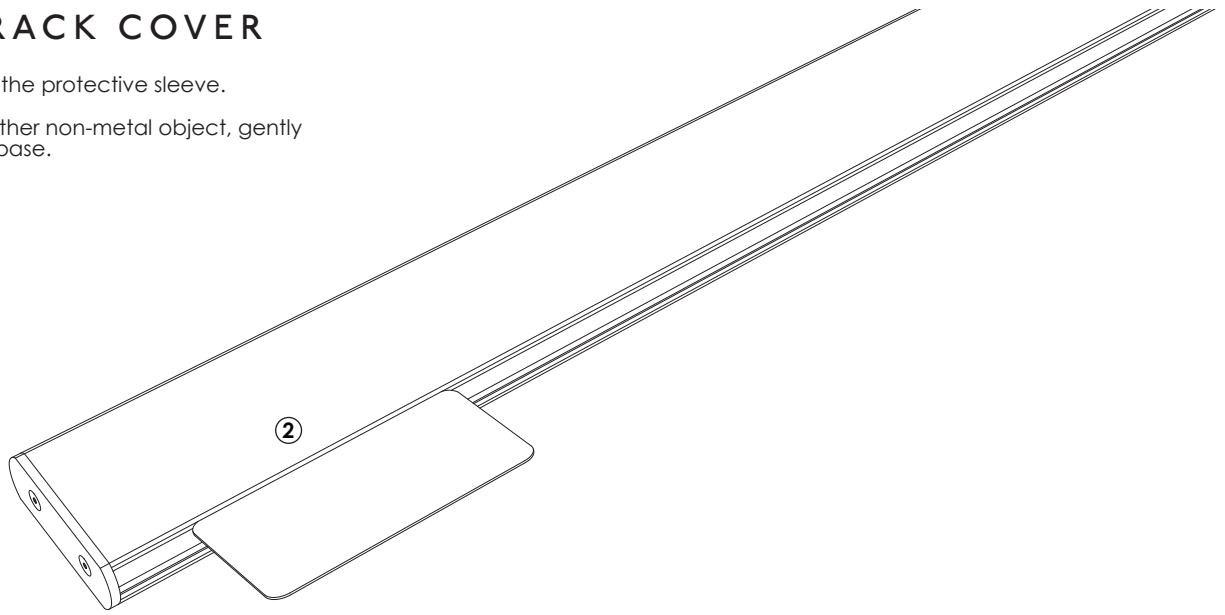

## 3. LOCATE TRACK ATTACHMENT POINTS

- ① Determine the height of the track centerline:  
 $HEIGHT = DOOR\ PANEL\ HEIGHT + 2-3/4''$   
 This will result in a 1/4" clearance between your door panel and the floor. Adjust if desired or necessary.
- ❗ Add 3/4" to this dimension if you are using the optional bottom guide channel.
- ② Mark the track centerline on your wall. (If you run a length of painter's tape along your wall, you'll thank us later!)
- ③ On the wall, mark the desired location of the end point of your track, ideally so that it aligns with the edge of your door panel in the desired closed position.
- ④ Determine and mark the locations of all mounting points along the track centerline. If your track was pre-drilled, simply transfer the hole pattern from the track to the wall. If you purchased an un-drilled track, see step 4.

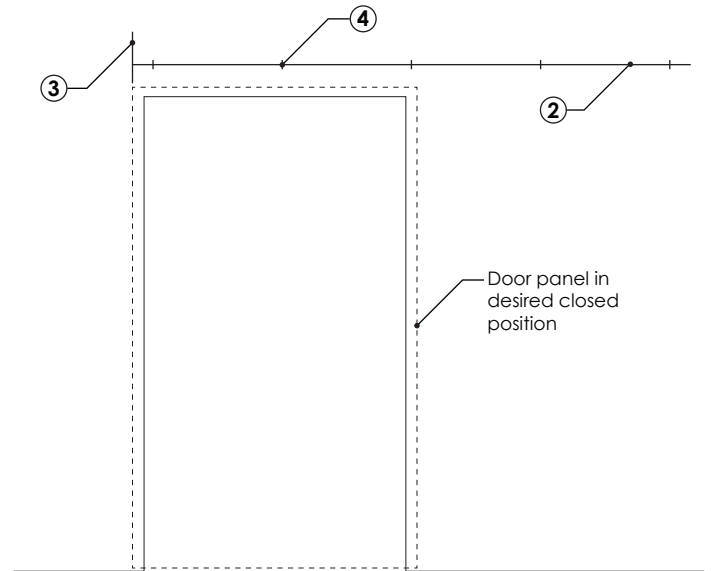

## 4. OPTIONAL STEP - UNDRILLED TRACK

- ① If you ordered an un-drilled track, first determine and mark your desired mounting point locations on the wall.
- ② Then mark and drill corresponding 9/16" holes in your track as shown.

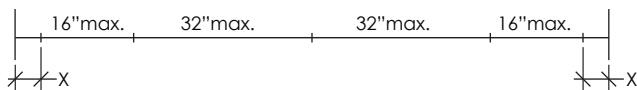

Panel weight	X*	Mounting points
up to 100lbs	6"	3 minimum
101 - 200 lbs	5"	3 minimum
201 - 300 lbs	4"	4 minimum
301 - 400 lbs	1.5"	5 minimum

\* Maximum length of track allowed beyond end mounting points

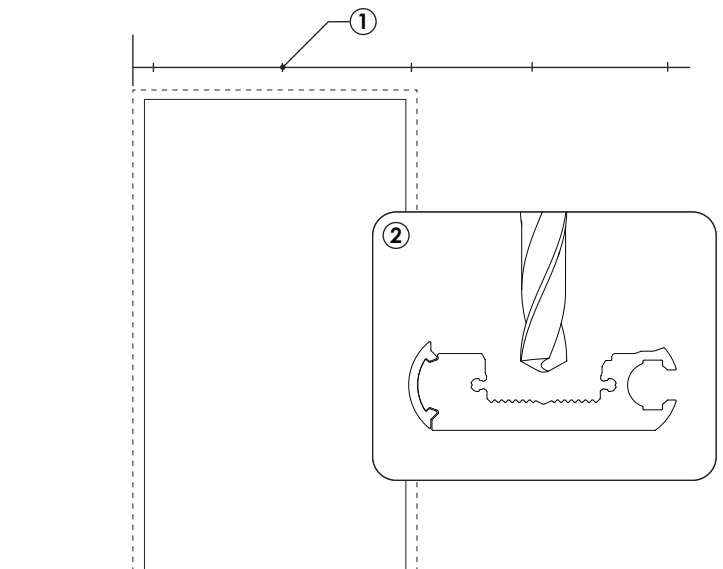

## 5. OPTIONAL STEP - LINK MULTIPLE TRACKS

- ① Using the provided allen keys, remove the end cap from the correct end of each track.
- ② Butt tracks end to end as they will be installed on your wall. Using the track connector washer plate centered over the seam between the tracks as a template, mark each track for drilling.
- ③ Drill a 13/64" hole in each track.
- ④ Connect tracks by assembling the track connector washer plate as shown. Ensure that washer teeth align with teeth in the track before tightening fasteners. Torque fasteners to 45 inch-lbs.

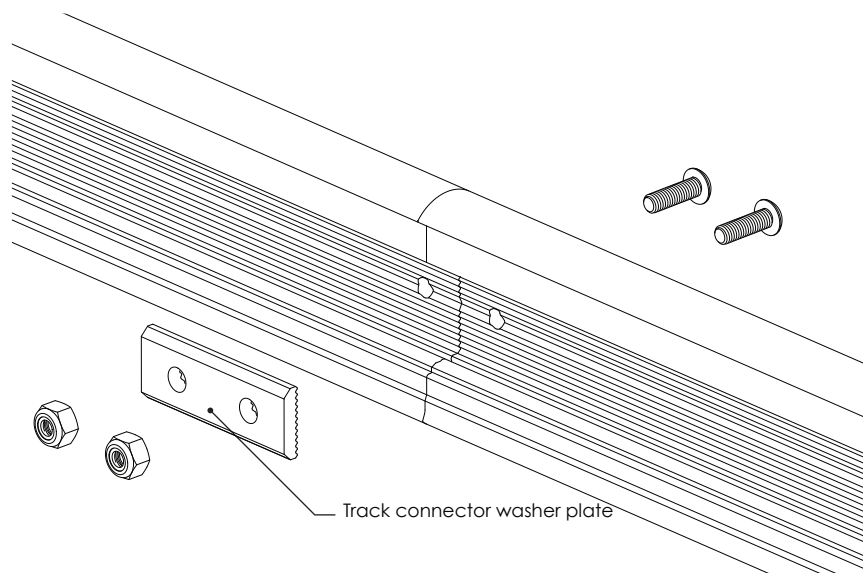

## 6. OPTIONAL STEP - INSTALL DRYWALL INSERTS

Recommended for high use installations and doors in excess of 200 lbs.

- ① Use a 1-3/4" spade bit to remove the drywall at each mounting point.
  - ② Place a drywall insert into each drywall cavity.
- ❗ To perform their function, drywall inserts must be up against the structural material of your wall and flush with the finished surface of the drywall. If needed, use the included steel shims as shown.

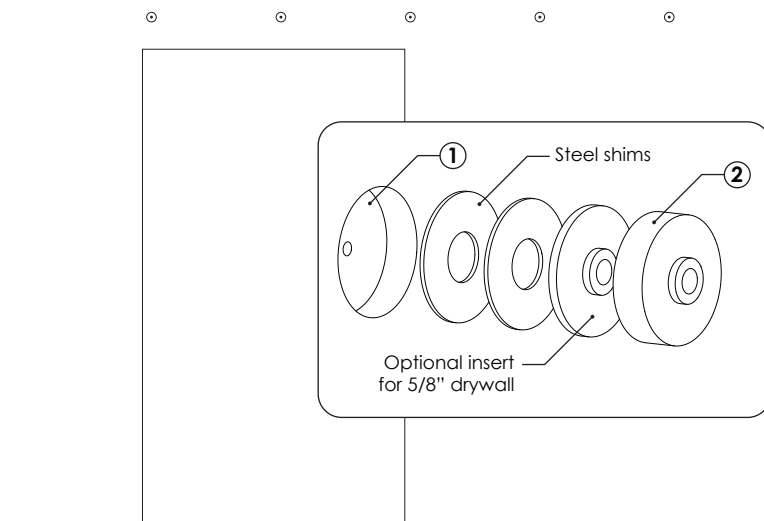

## 7. PREPARE WALL

- ① Drill a pilot hole for each mounting point.
- ❗ Make sure that each mounting point engages an appropriate amount of structural material:
- A. Wood or metal stud framed walls must have 3" of solid wood blocking secured to studs or other framing members.
  - B. Concrete and masonry walls must be solid and thicker than the minimum required thread engagement of 1-1/2".
  - C. Steel beams must be structural in nature and have a minimum wall thickness of 1/4". Note that you cannot attach this hardware to sheet metal studs.

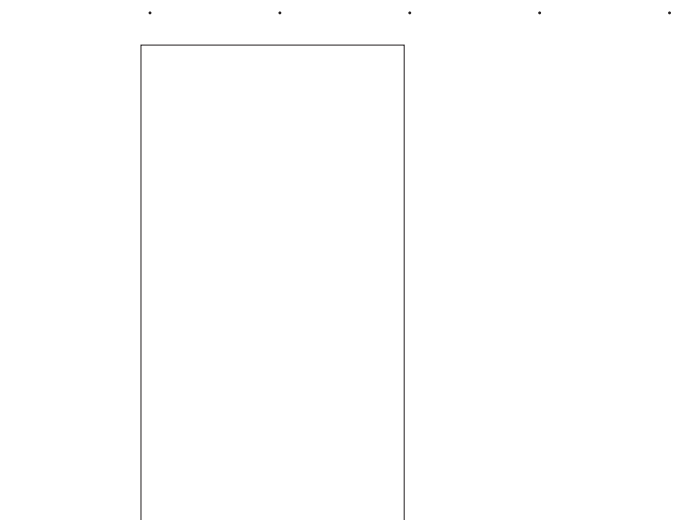

## 8. DETERMINE DESIRED WALL CLEARANCE

- ① Taking baseboard and door frame into consideration, determine if you need to use the optional track stand-off based on the wall clearance dimensions at right.

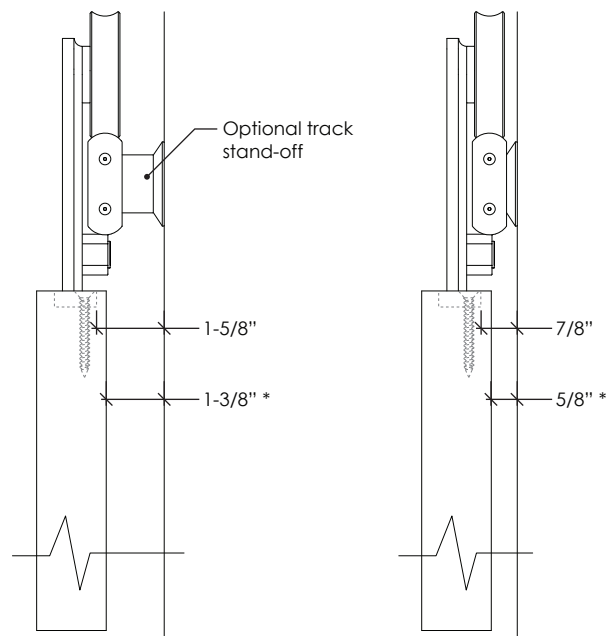
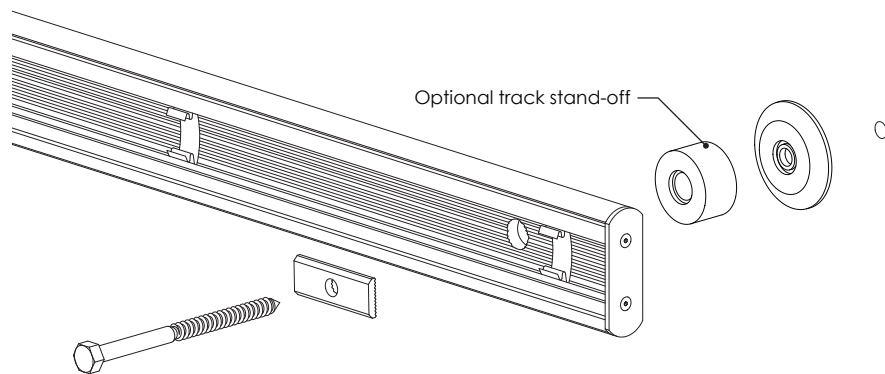

\* Approximate maximum clearance. Dependant on door panel material.

## 9. OPTIONAL STEP - INSTALL PERPENDICULAR WALL FITTING

- ① Remove the pre-installed end cap and replace it with the perpendicular wall fitting end cap.
- ② Temporarily stage the track in the desired position on the wall. Mark the track outline on the wall.
- ③ Carefully remove the drywall inside the outlined area. See dimensions at right.
- ④ Install the wall plate in the drywall cavity. Ensure that the plate is up against the structural material of the wall.
- ⑤ Fully insert the washer plate into the rectangular hole of the wall plate. Butt the track up to the wall and mark the holes from the washer plate on the track. Drill two 13/64" holes in the track.
- ⑥ Attach the washer plate to the track as shown. Ensure that washer teeth align with teeth in the track before tightening fasteners. Torque fasteners to 45 inch-lbs.
- ⑦ Oval holes in wall plate allow for track position to be horizontally adjusted if necessary.
- ⑧ Teeth on washer plate and track allow for track position to be vertically adjusted if necessary.

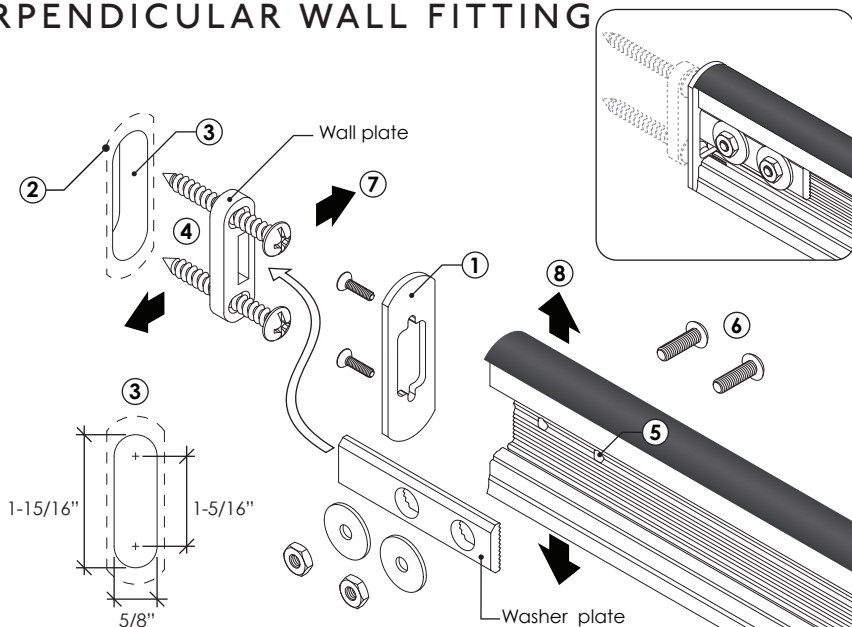

## 10. MOUNT TRACK TO WALL

- ① Ensuring that the black plastic track cap faces up, loosely install one end of your track with the appropriate track spacers and hardware.
- ② Repeat with the opposite end of the track.
- ③ Support the track assembly along its length if multiple tracks are linked together.
- ④ With both ends of the track now supported, loosely install the remaining mounting points.

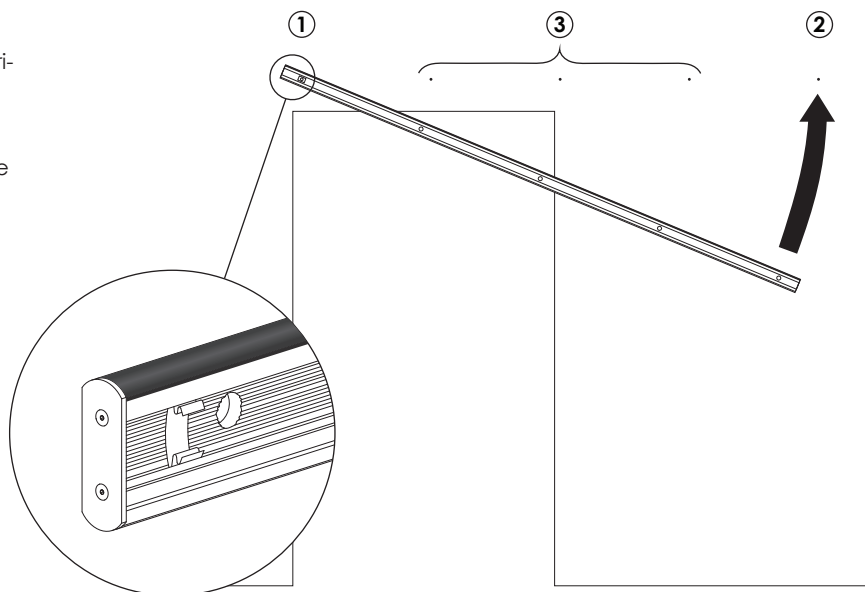

## 11. ADJUST TRACK HEIGHT

- 1 Tighten each track fastener starting at the center and moving toward the ends. For maximum adjustability, start by positioning the washer plate in the center (neutral) position.
  - 2 Level the track by adjusting the position of the washer plate at each mounting point.
- ⚠ Ensure that washer teeth align with teeth in the track before tightening fasteners.

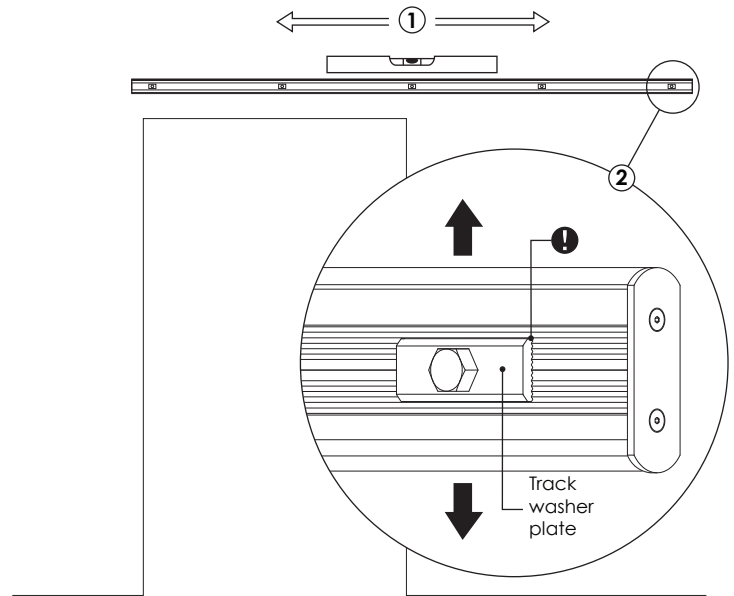

## 12. OPTIONAL STEP - INSTALL TRACK SHIMS

- 1 Sight down the length of your track to determine if unevenness in the wall is causing your track to bow. If necessary:
  - 2 Loosen track attachment points as needed and insert shims from below. Ensure that the opening of the shim faces up. Start with one of the thinner shims, adding and swapping shims as needed until the track is straight to within the thickness of one shim.
- ⚠ If optional track stand-offs are installed, do not use more than one shim kit per mounting point.

NOTE: Bowing in the track will negatively affect the performance of the entire system, causing increased friction and excessive wear on some components. Krownlab's warranty does not cover wear caused by improper installation.

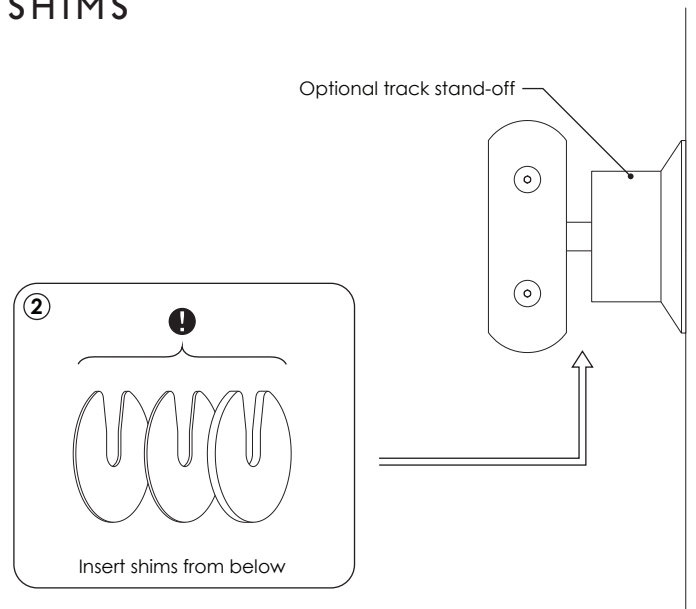

## 13. ATTACH TRACK COVER

- 1 After the track has been leveled, shimmed, and all mounting points have been securely fastened to 120 inch-lbs, reattach the track cover.
- ⚠ Ensure that the arrow on the inside of the track cover is facing up.

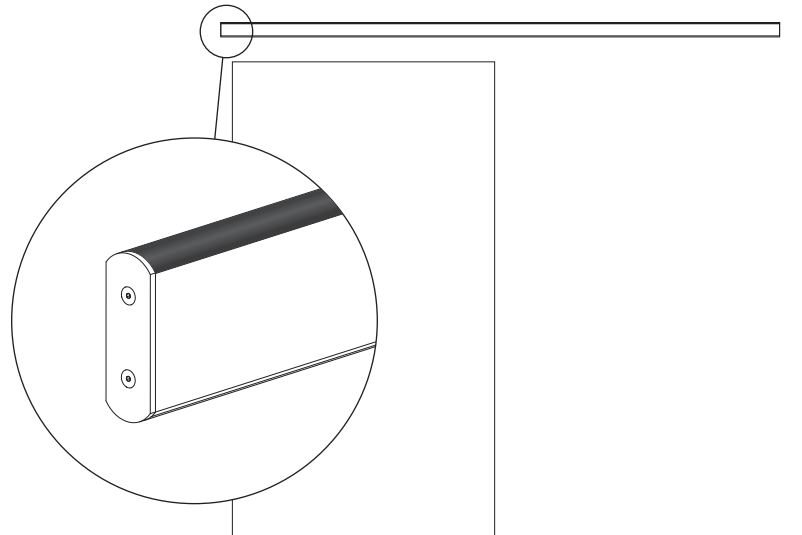
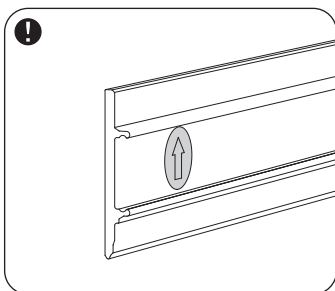

## 14. ATTACH DOOR STOPS

- 1 Locate the preinstalled nuts in the bottom of the track. Loosely screw a door stop to each nut.
- 2 Temporarily slide one door stop to each end of the track. Do not tighten the stops until step 20.

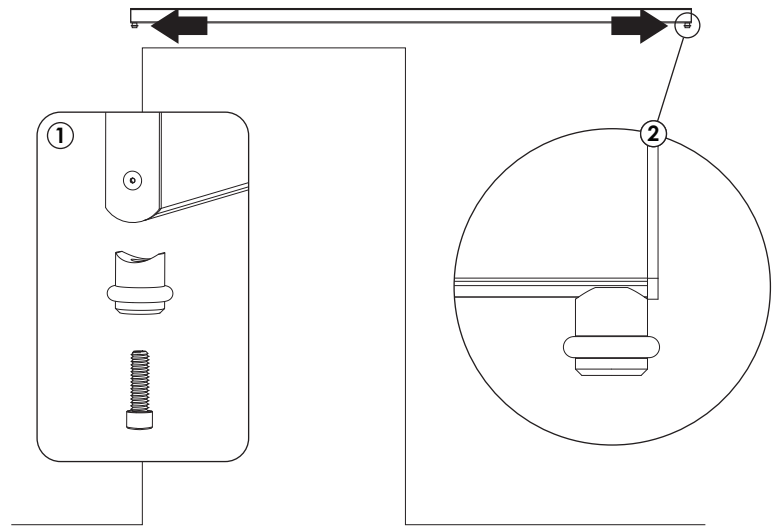

## 15. PREPARE BOTTOM GUIDE

- 1 If you have purchased an optional bottom guide channel, attach it using the screws supplied. If necessary, cut the length of the channel to match the width of the door panel.
- 2 If you have not purchased an optional bottom guide channel, route the bottom of your door panel along its entire length, as shown.



Installation of a bottom guide solution is a mandatory step for safety reasons.

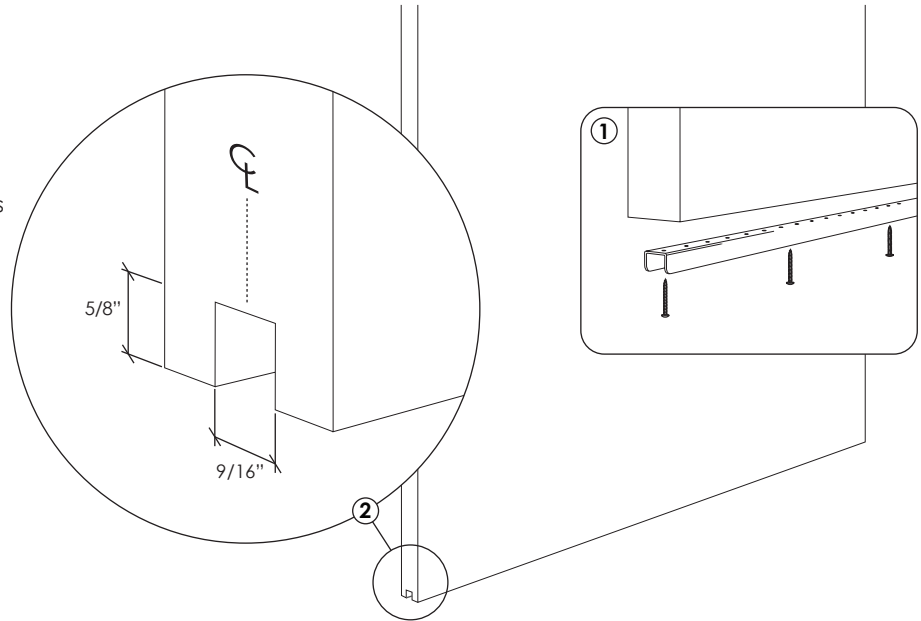

## 16. ROUTE DOOR PANEL

- 1 Route the top of the door panel to accept the trolleys as shown.
- 2 Also prep for, but do not yet install, your door pulls or other door hardware.
- 3 Adjust location of recess to achieve the right door panel clearance from wall and door trim. Minimum dimension is driven by door panel material.

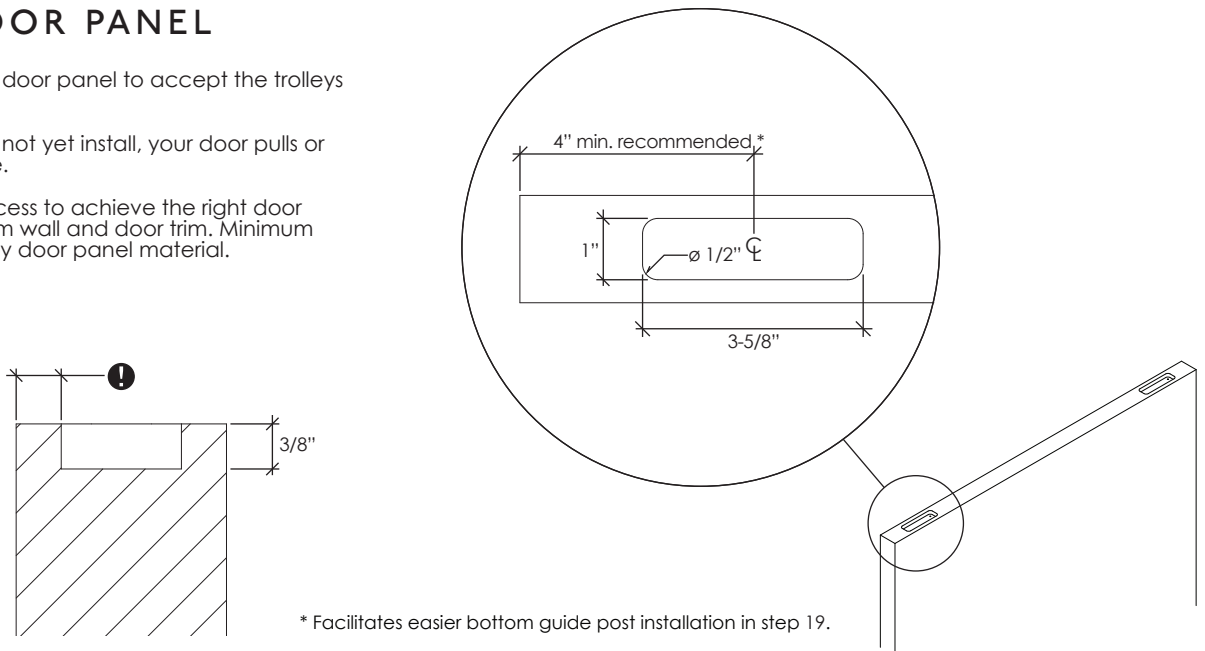

\* Facilitates easier bottom guide post installation in step 19.

## 17. ATTACH TROLLEYS TO DOOR PANEL

- 1 Pre-drill and attach the trolleys using the fasteners provided. Make sure that the trolleys are secured parallel to the face of the door panel
  - 2 Remove the trolley stops with the provided 9" wrench. Note how tight the screws are. You will need to tighten the screws to this same tension when the trolley stops are reinstalled.
  - 3 Carefully hang your panel.
- ⚠ Do not yet install your door pulls or other door hardware.



No trolley stops are installed at this time. Panel may roll off end of track.

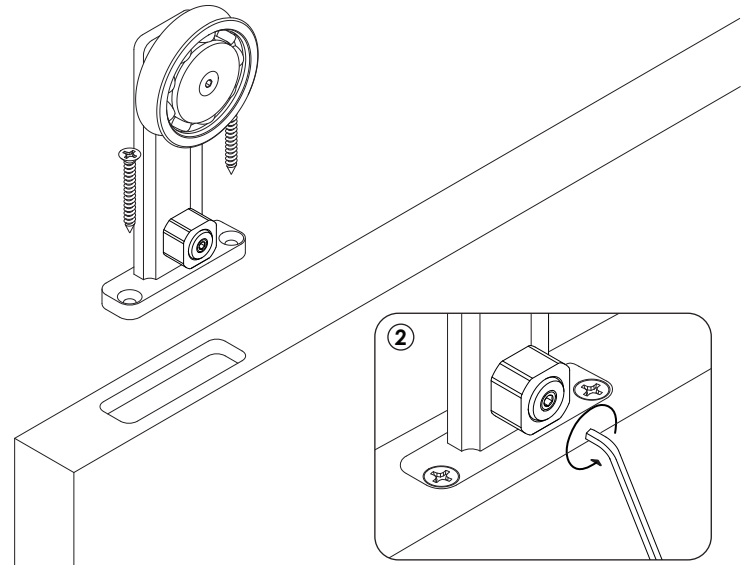

## 18. REINSTALL TROLLEY STOPS

- 1 Place the trolley stop assembly on the back of the trolley.
  - 2 Align interlocking features and fully seat the trolley stop. Note that a properly seated trolley stop will have interlocking features fully engaged and you will not be able to twist it.
  - 3 Thread and tighten the trolley stop screw using your fingers until finger-tight.
  - 4 Slide the provided 9" wrench behind the track and firmly tighten the screw to 45 inch-lbs. Please note this is the same tightness the screw had when it arrived.
  - 5 Repeat above steps for second trolley
- ⚠ In some instances, the screw may also be accessed from inside the door opening. This may aid installation.

Note: Please keep the 9" wrench to make it easier to uninstall your sliding door.

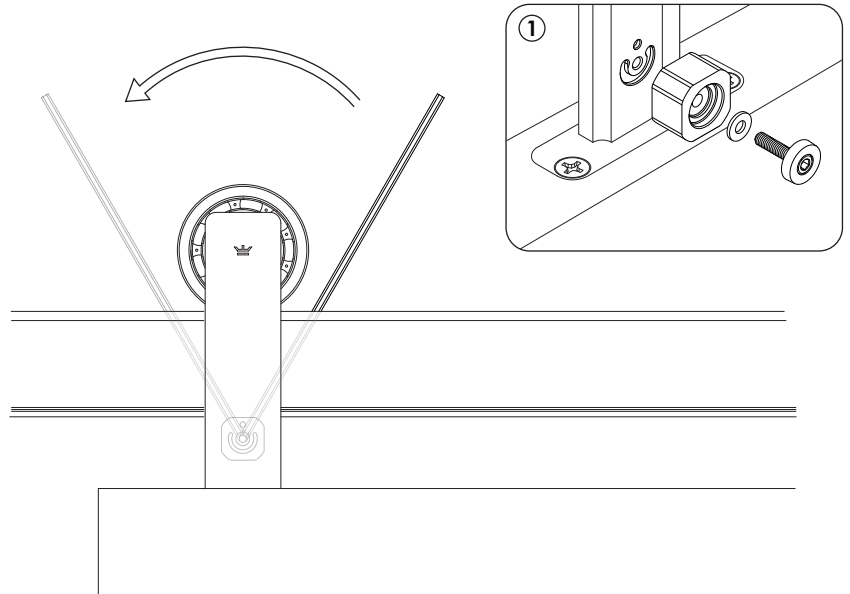

## 19. INSTALL BOTTOM GUIDE POST

- 1 With the door in the desired closed position, mark the leading edge of your door panel.
  - 2 With the door in the desired open position, mark the trailing edge of your door panel.
  - 3 Temporarily move the door panel beyond the fully open position, revealing the overlap area.
  - 4 Install the bottom guide post in the overlap area. Position the post at the appropriate distance from the wall so that the panel hangs plumb.
  - 5 You can now install your door pulls and other door hardware.
- ⚠ Installation of bottom guide is mandatory. Door panel has to be engaged by bottom guide along its entire travel. Door has to be installed plumb.



Not following the above instructions can cause a hazardous condition.

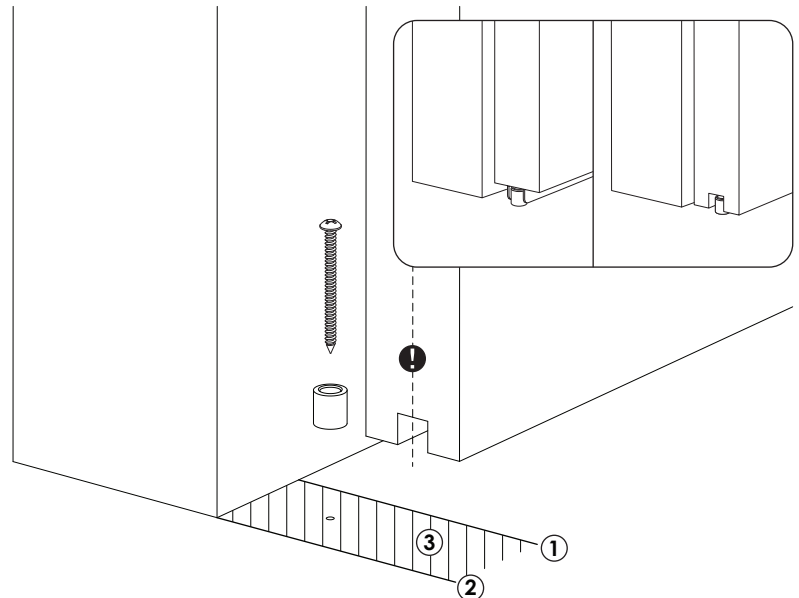

## 20. POSITION DOOR STOPS

- 1 With the door in the desired closed position, slide the door stop so that it touches the trolley stop of the trailing trolley. Tighten the door stop in place to 110 inch-lbs.
- 2 Repeat with the door in the open position, sliding the door stop so that it touches the trolley stop of the leading trolley.
- 3 Verify that the bottom guide post is properly engaged in the fully open and fully closed positions.

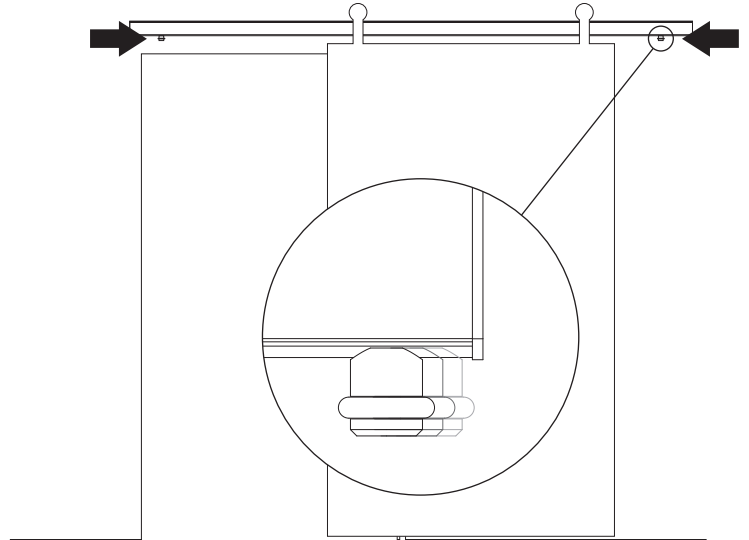

## 21. OPTIONAL STEP - INSTALL DOOR BOTTOM STOP

- 1 Recommended for heavy and high-use door panels.
- 2 With the door in the desired closed position, install the door bottom stop so that it touches the trailing edge of the door panel.
- 3 Repeat with the door in the open position, installing the door bottom stop so that it touches the leading edge of the door panel.

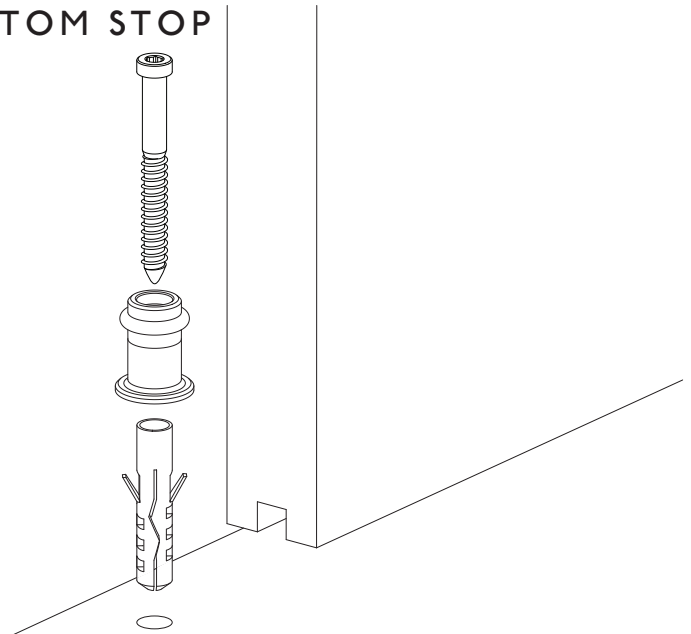

## 22. PRODUCT CARE

### Common Parts

Wheels (bearings) should occasionally be lubricated with bearing oil (e.g. SHC 630 Synthetic Gear and Bearing Oil by Exxon Mobil Corp: [www.mobil.com](http://www.mobil.com)).

### Brushed Stainless

To clean any time after installation, use a non-abrasive lint free cloth or sponge and household glass cleaner. (Remember to test an inconspicuous area prior to cleaning hardware.) Do not use steel wool, or a Scotch Brite pad, as it can scratch the product.

### Black Stainless

To enhance the depth and shine of the finish, periodically apply a thin coating of petroleum jelly with a clean cloth, buff clean and dry. Do not use steel wool, or a Scotch Brite pad, as it can scratch the product.

Product may be covered by pending and awarded U.S. patents. For more information visit [www.krownlab.com](http://www.krownlab.com)



### RAGNAR+ODEN

TOP MOUNT, BI-PARTING

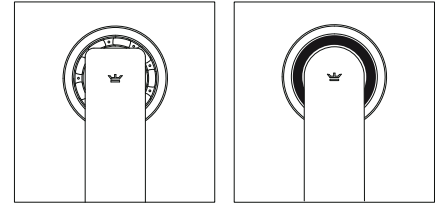

## I. VERIFY ALL COMPONENTS

### BASE KIT

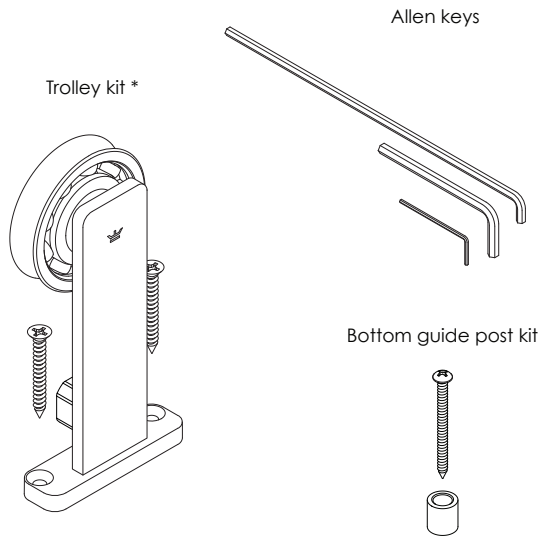
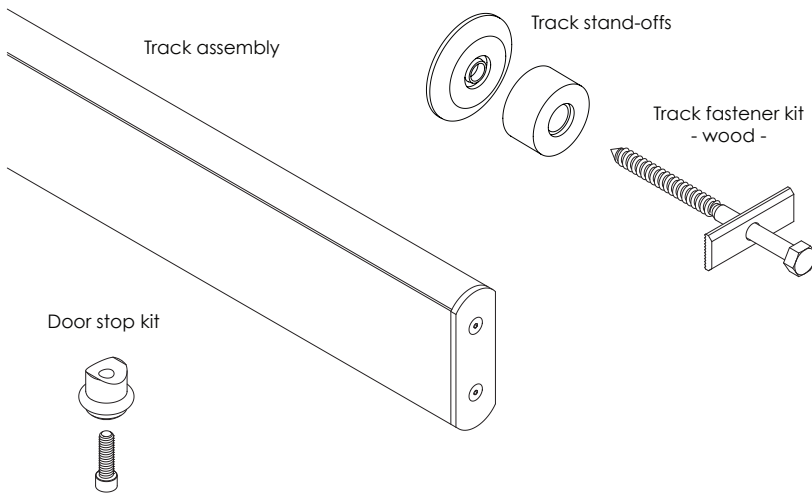

\* Illustration is based on Ragnar

## SYSTEM OPTIONS AND ADDITIONS

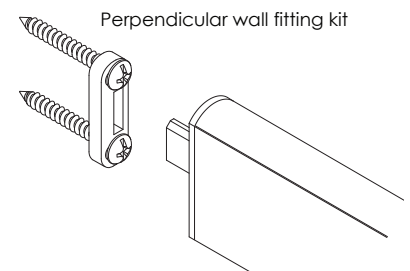
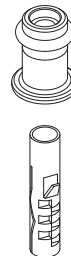
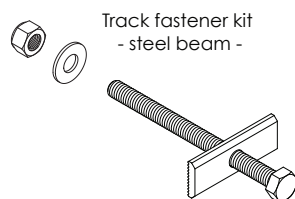
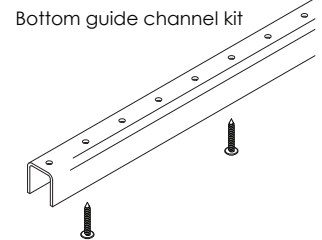
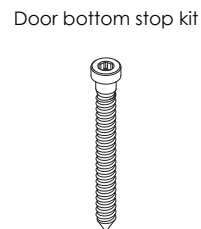
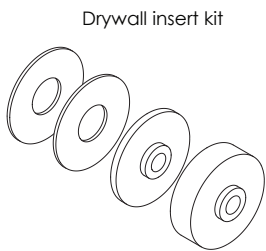

## 2. REMOVE TRACK COVER

- ① Remove the track from the protective sleeve.
- ② Using a credit card or other non-metal object, gently pry the cover from the base.

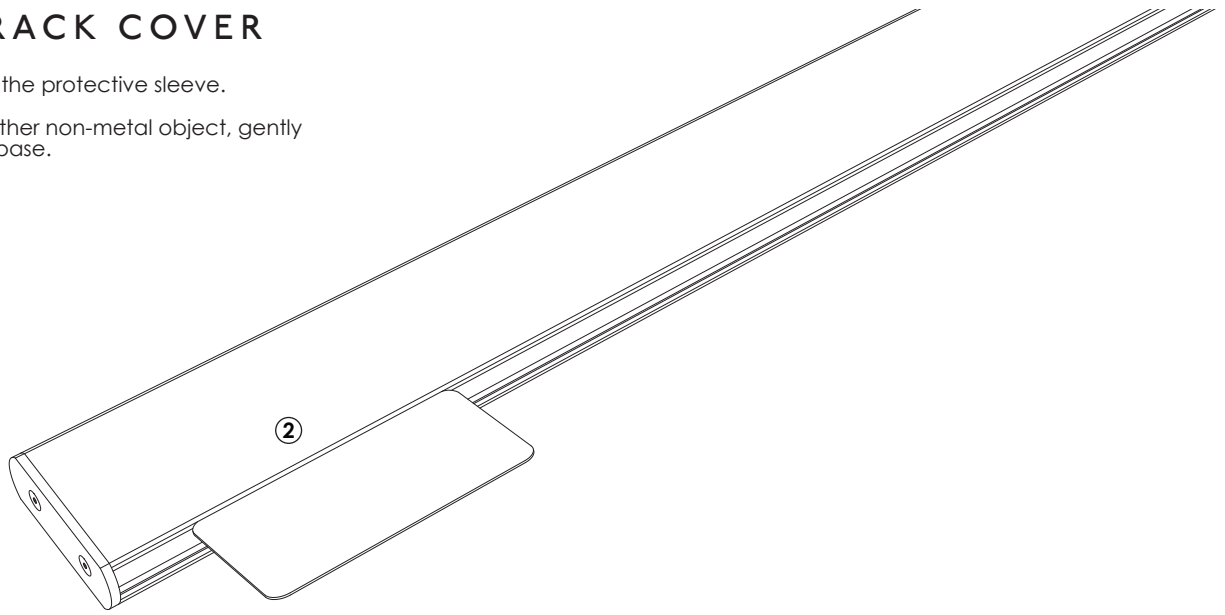

## 3. LOCATE TRACK ATTACHMENT POINTS

- ① Determine the height of the track centerline:  
 $HEIGHT = DOOR\ PANEL\ HEIGHT + 2-3/4"$   
 This will result in a 1/4" clearance between your door panel and the floor. Adjust if desired or necessary.
- ⚠ Add 3/4" to this dimension if you are using the optional bottom guide channel.
- ② Mark the track centerline on your wall. (If you run a length of painter's tape along your wall, you'll thank us later!)
- ③ On the wall, mark the desired location of the middle point of your track.
- ④ Determine and mark the locations of all mounting points along the track centerline. If your track was pre-drilled, simply transfer the hole pattern from the track to the wall. If you purchased an un-drilled track, see step 4.

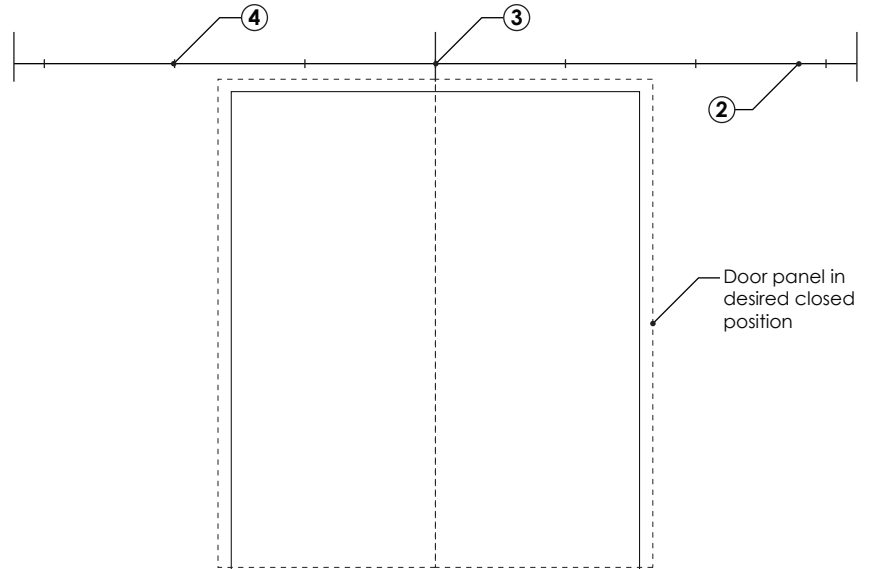

## 4. OPTIONAL STEP - UNDRILLED TRACK

- ① If you ordered an un-drilled track, first determine and mark your desired mounting point locations on the wall.
- ② Then mark and drill corresponding 9/16" holes in your track as shown.

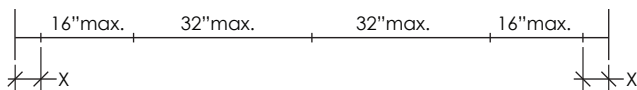

Panel weight	X*	Mounting points
up to 100lbs	6"	3 minimum
101 - 200 lbs	5"	3 minimum
201 - 300 lbs	4"	4 minimum
301 - 400 lbs	1.5"	5 minimum

\* Maximum length of track allowed beyond end mounting points

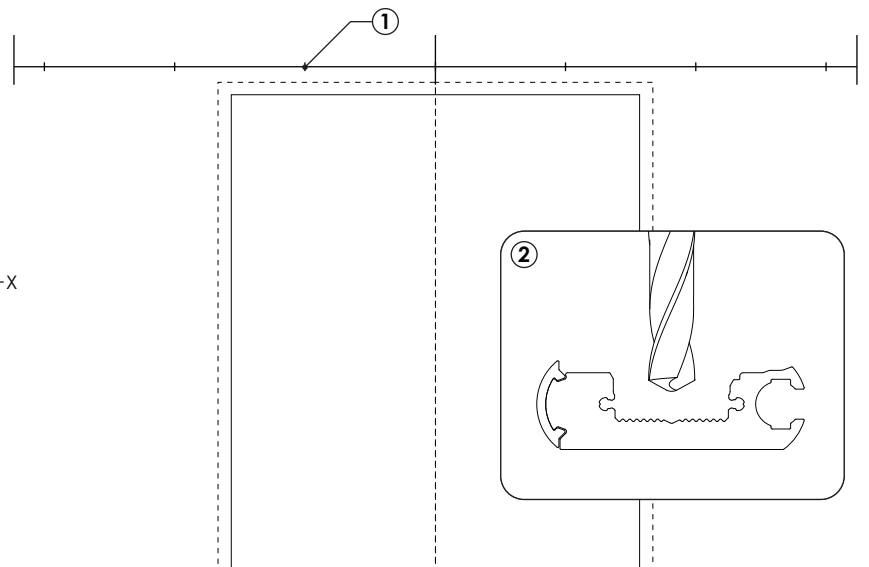

## 5. OPTIONAL STEP - LINK MULTIPLE TRACKS

- ① Using the provided allen keys, remove the end cap from the correct end of each track.
- ② Butt tracks end to end as they will be installed on your wall. Using the track connector washer plate centered over the seam between the tracks as a template, mark each track for drilling.
- ③ Drill a 13/64" hole in each track.
- ④ Connect tracks by assembling the track connector washer plate as shown. Ensure that washer teeth align with teeth in the track before tightening fasteners. Torque fasteners to 45 inch-lbs.

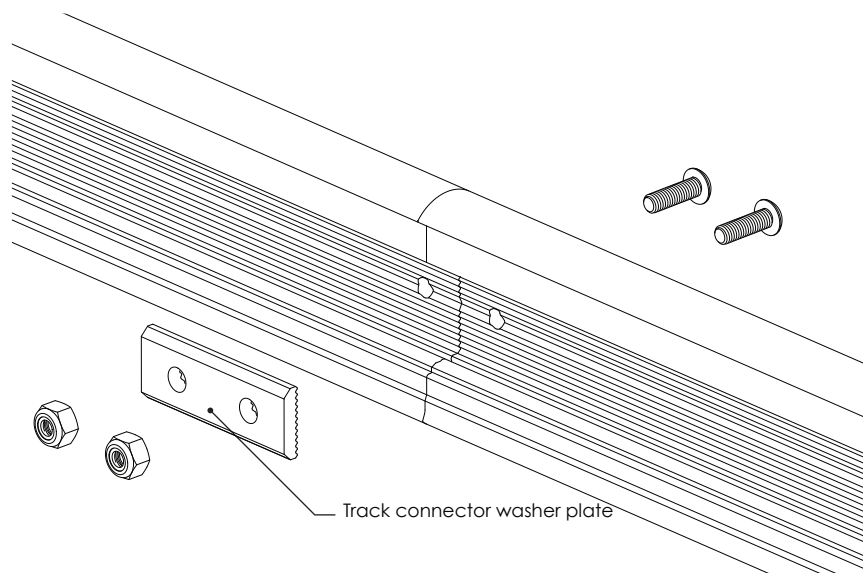

## 6. OPTIONAL STEP - INSTALL DRYWALL INSERTS

Recommended for high use installations and doors in excess of 200 lbs.

- ① Use a 1-3/4" spade bit to remove the drywall at each mounting point.
  - ② Place a drywall insert into each drywall cavity.
- ❗ To perform their function, drywall inserts must be up against the structural material of your wall and flush with the finished surface of the drywall. If needed, use the included steel shims as shown.

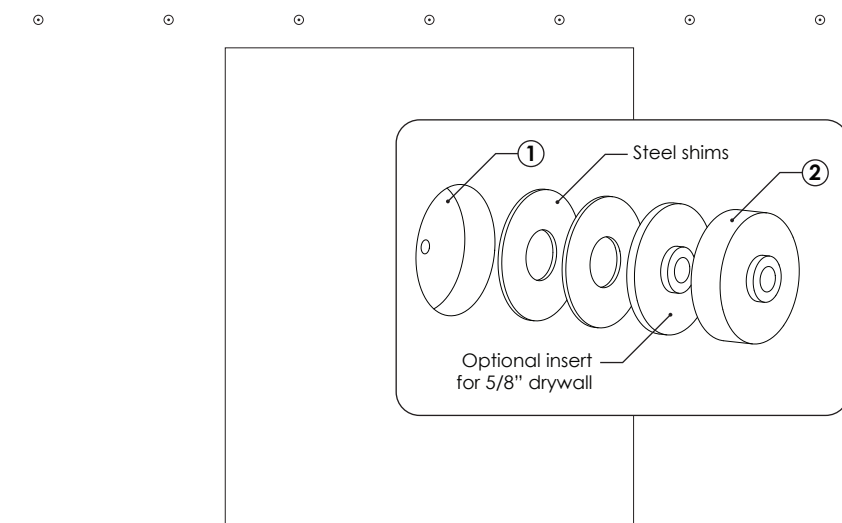

## 7. PREPARE WALL

- ① Drill a pilot hole for each mounting point.
- ❗ Make sure that each mounting point engages an appropriate amount of structural material:
- A. Wood or metal stud framed walls must have 3" of solid wood blocking secured to studs or other framing members.
  - B. Concrete and masonry walls must be solid and thicker than the minimum required thread engagement of 1-1/2".
  - C. Steel beams must be structural in nature and have a minimum wall thickness of 1/4". Note that you cannot attach this hardware to sheet metal studs.

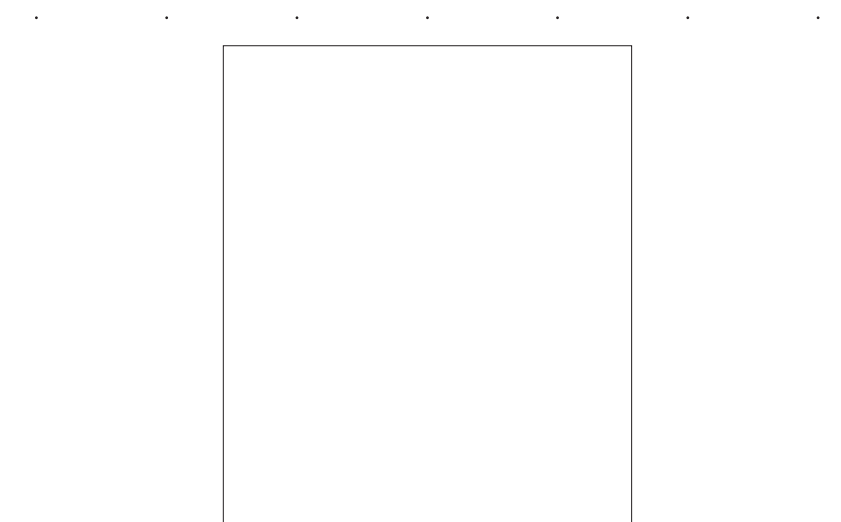

## 8. DETERMINE DESIRED WALL CLEARANCE

- ① Taking baseboard and door frame into consideration, determine if you need to use the optional track stand-off based on the wall clearance dimensions at right.

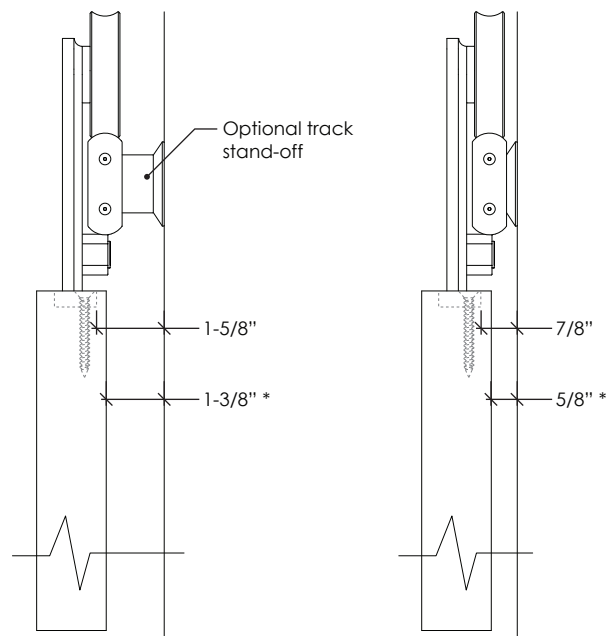
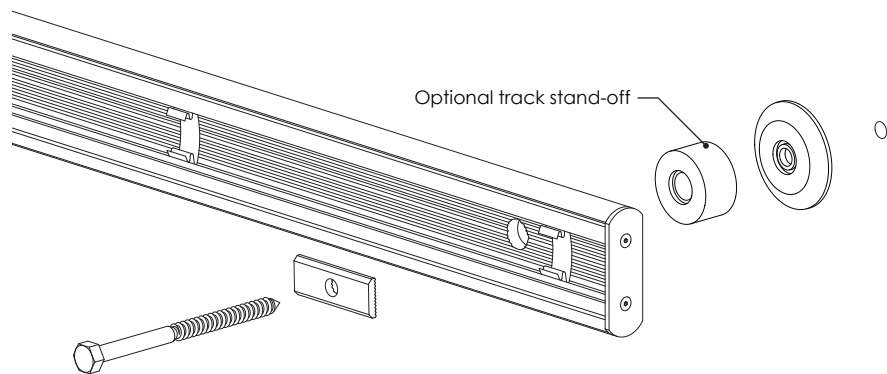

\* Approximate maximum clearance. Dependant on door panel material.

## 9. OPTIONAL STEP - INSTALL PERPENDICULAR WALL FITTING

- ① Remove the pre-installed end cap and replace it with the perpendicular wall fitting end cap.
- ② Temporarily stage the track in the desired position on the wall. Mark the track outline on the wall.
- ③ Carefully remove the drywall inside the outlined area. See dimensions at right.
- ④ Install the wall plate in the drywall cavity. Ensure that the plate is up against the structural material of the wall.
- ⑤ Fully insert the washer plate into the rectangular hole of the wall plate. Butt the track up to the wall and mark the holes from the washer plate on the track. Drill two 13/64" holes in the track.
- ⑥ Attach the washer plate to the track as shown. Ensure that washer teeth align with teeth in the track before tightening fasteners. Torque fasteners to 45 inch-lbs.
- ⑦ Oval holes in wall plate allow for track position to be horizontally adjusted if necessary.
- ⑧ Teeth on washer plate and track allow for track position to be vertically adjusted if necessary.

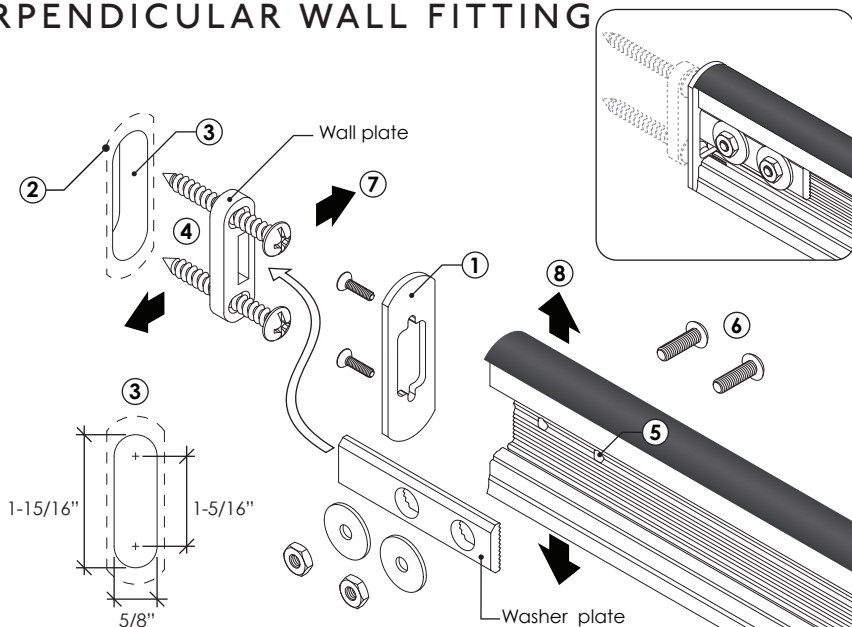

## 10. MOUNT TRACK TO WALL

- ① Ensuring that the black plastic track cap faces up, loosely install one end of your track with the appropriate track spacers and hardware.
- ② Repeat with the opposite end of the track.
- ③ Support the track assembly along its length if multiple tracks are linked together.
- ④ With both ends of the track now supported, loosely install the remaining mounting points.

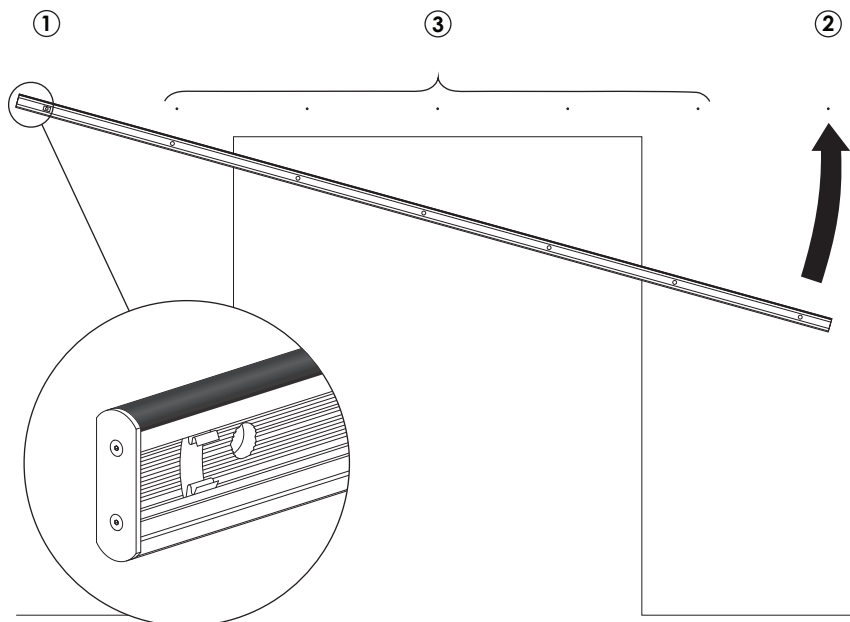

## 11. ADJUST TRACK HEIGHT

- 1 Tighten each track fastener starting at the center and moving toward the ends. For maximum adjustability, start by positioning the washer plate in the center (neutral) position.
  - 2 Level the track by adjusting the position of the washer plate at each mounting point.
- ⚠ Ensure that washer teeth align with teeth in the track before tightening fasteners.

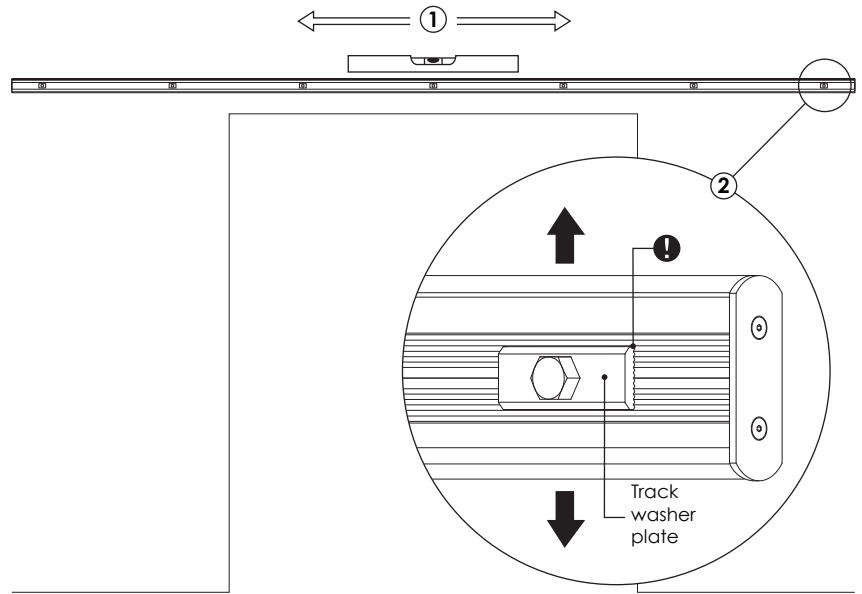

## 12. OPTIONAL STEP - INSTALL TRACK SHIMS

- 1 Sight down the length of your track to determine if unevenness in the wall is causing your track to bow. If necessary:
  - 2 Loosen track attachment points as needed and insert shims from below. Ensure that the opening of the shim faces up. Start with one of the thinner shims, adding and swapping shims as needed until the track is straight to within the thickness of one shim.
- ⚠ If optional track stand-offs are installed, do not use more than one shim kit per mounting point.

NOTE: Bowing in the track will negatively affect the performance of the entire system, causing increased friction and excessive wear on some components. Krownlab's warranty does not cover wear caused by improper installation.

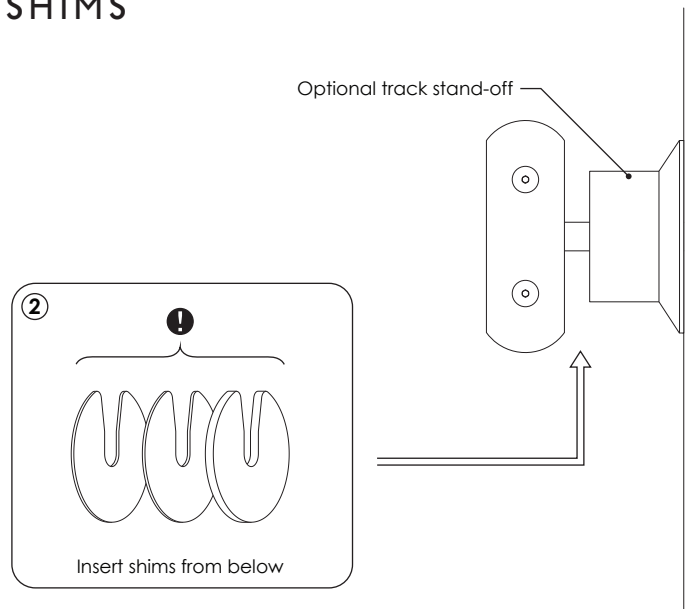

## 13. ATTACH TRACK COVER

- 1 After the track has been leveled, shimmed, and all mounting points have been securely fastened to 120 inch-lbs, reattach the track cover.
- ⚠ Ensure that the arrow on the inside of the track cover is facing up.

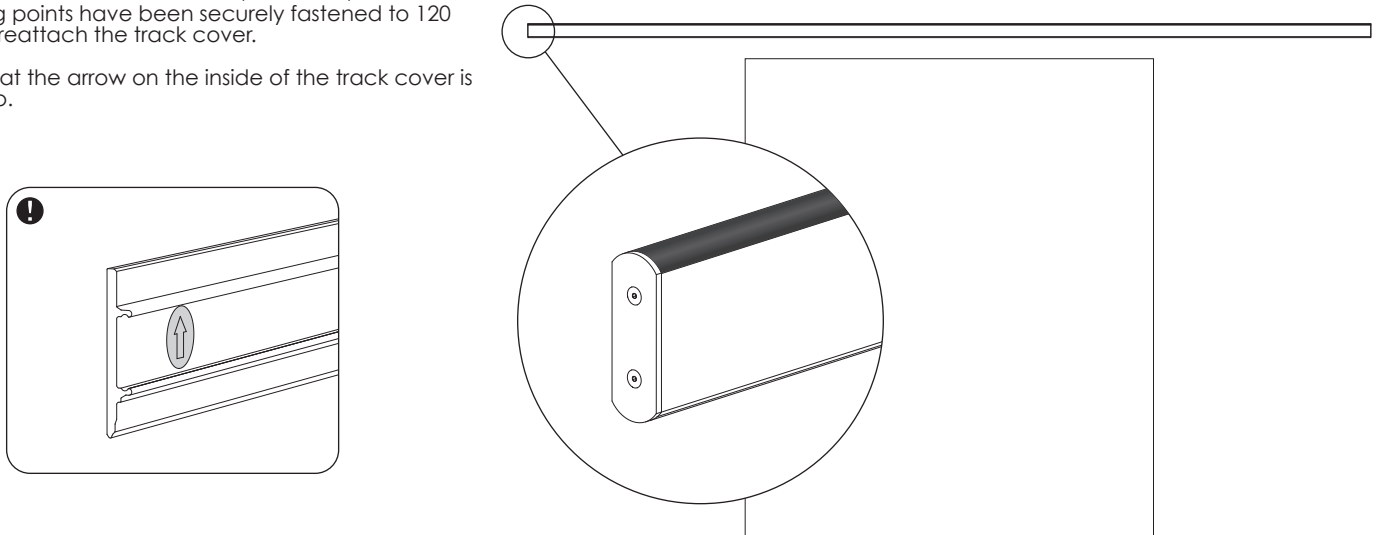

## 14. ATTACH DOOR STOPS

- ① Locate the preinstalled nuts in the bottom of the track. Loosely screw a door stop to each nut.
- ② Temporarily slide door stops to the center and ends of the track. Do not tighten the stops until step 20.

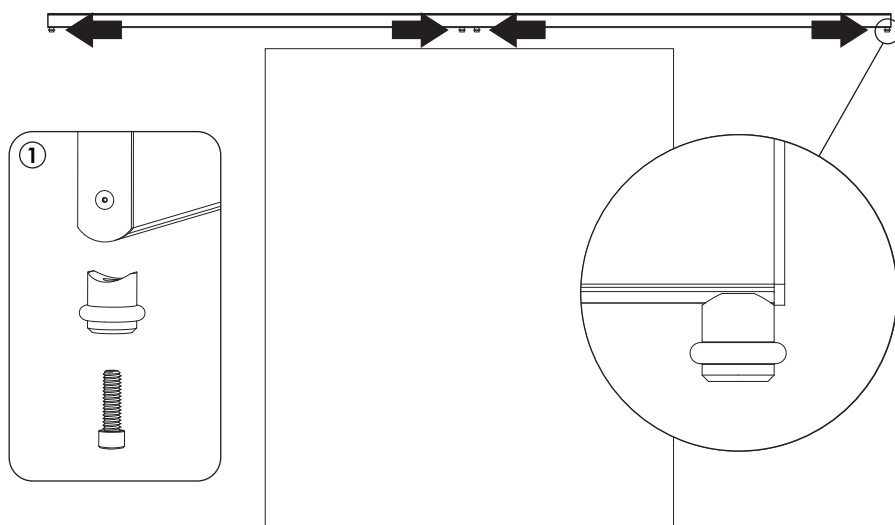

## 15. PREPARE BOTTOM GUIDE

- ① If you have purchased an optional bottom guide channel, attach it using the screws supplied. If necessary, cut the length of the channel to match the width of the door panel.
- ② If you have not purchased an optional bottom guide channel, route the bottom of your door panel along its entire length, as shown.



Installation of a bottom guide solution is a mandatory step for safety reasons.

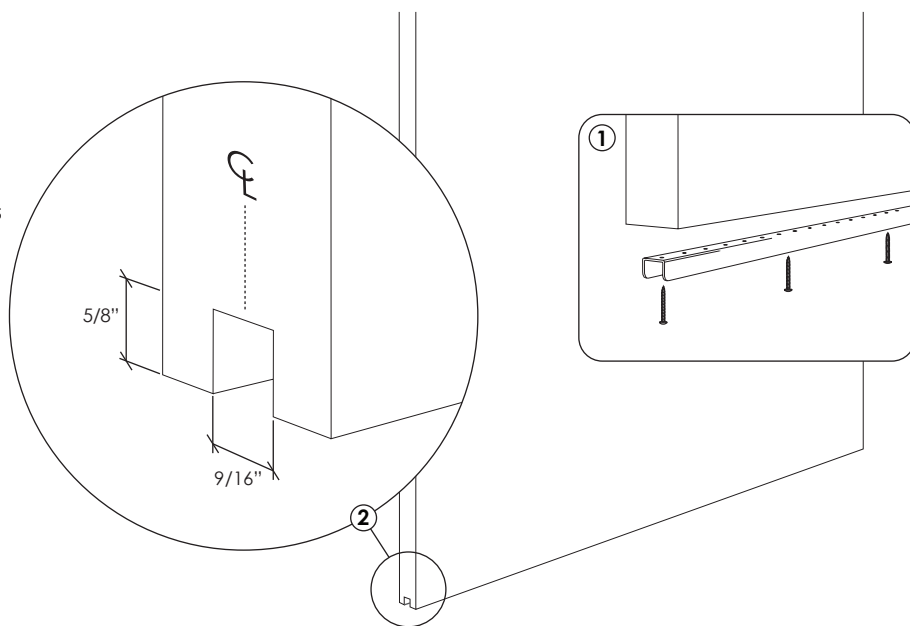

## 16. ROUTE DOOR PANEL

- ① Route the top of the door panel to accept the trolleys as shown.
- ② Also prep for, but do not yet install, your door pulls or other door hardware.
- ❗ Adjust location of recess to achieve the right door panel clearance from wall and door trim. Minimum dimension is driven by door panel material.

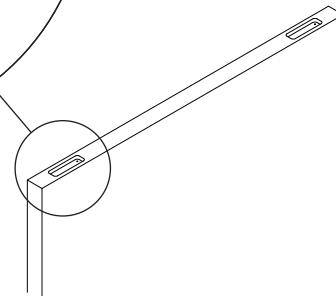
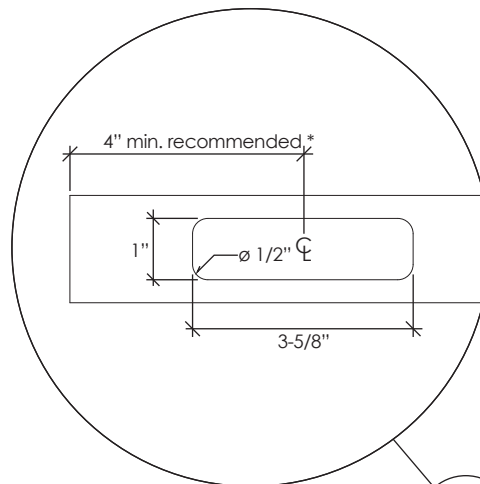
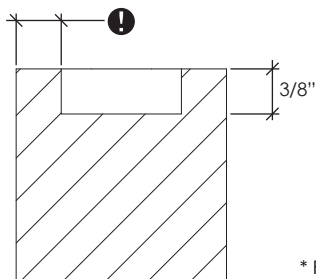

\* Facilitates easier bottom guide post installation in step 19.

## 17. ATTACH TROLLEYS TO DOOR PANEL

- ① Pre-drill and attach the trolleys using the fasteners provided. Make sure that the trolleys are secured parallel to the face of the door panel
  - ② Remove the trolley stops with the provided 9" wrench. Note how tight the screws are. You will need to tighten the screws to this same tension when the trolley stops are reinstalled.
  - ③ Carefully hang your panel.
- ⚠ Do not yet install your door pulls or other door hardware.



No trolley stops are installed at this time. Panel may roll off end of track.

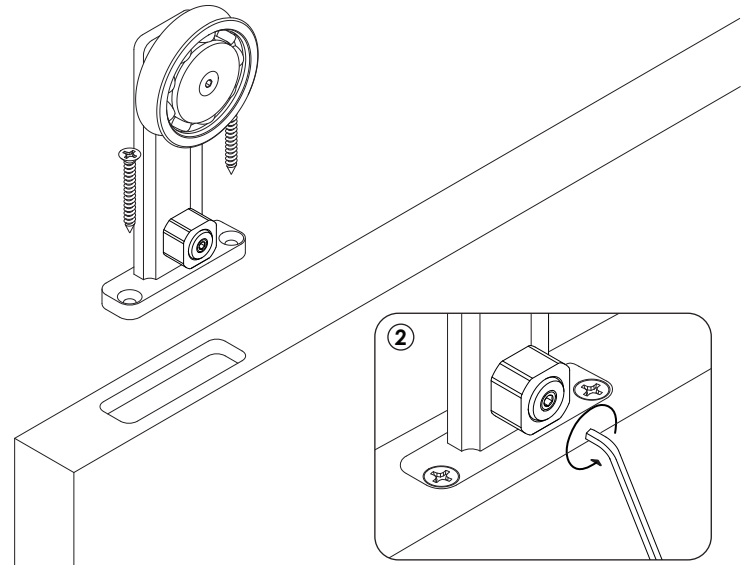

## 18. REINSTALL TROLLEY STOPS

- ① Place the trolley stop assembly on the back of the trolley.
  - ② Align interlocking features and fully seat the trolley stop. Note that a properly seated trolley stop will have interlocking features fully engaged and you will not be able to twist it.
  - ③ Thread and tighten the trolley stop screw using your fingers until finger-tight.
  - ④ Slide the provided 9" wrench behind the track and firmly tighten the screw to 45 inch-lbs. Please note this is the same tightness the screw had when it arrived.
  - ⑤ Repeat above steps for second trolley
- ⚠ In some instances, the screw may also be accessed from inside the door opening. This may aid installation.

Note: Please keep the 9" wrench to make it easier to uninstall your sliding door.

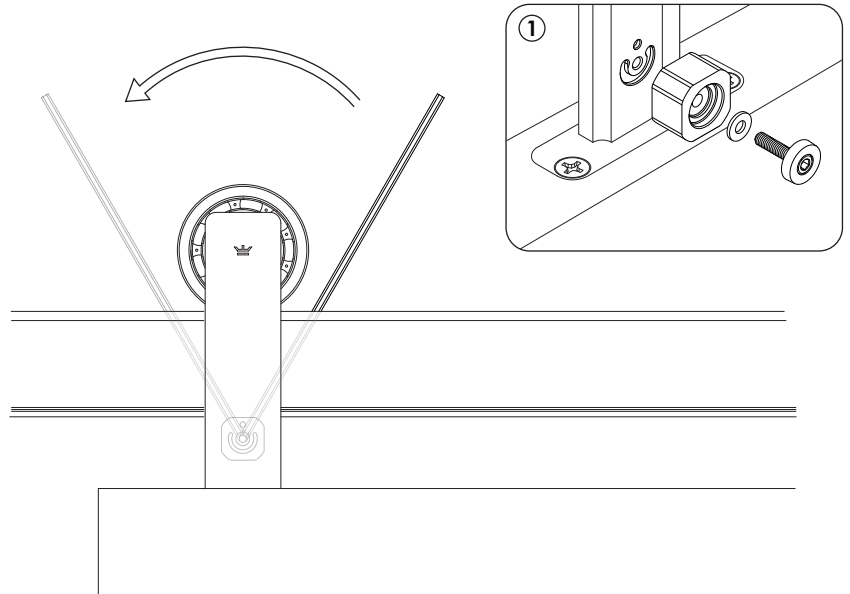

## 19. INSTALL BOTTOM GUIDE POST

- ① With the door in the desired closed position, mark the leading edge of your door panel.
  - ② With the door in the desired open position, mark the trailing edge of your door panel.
  - ③ Temporarily move the door panel beyond the fully open position, revealing the overlap area.
  - ④ Install the bottom guide post in the overlap area. Position the post at the appropriate distance from the wall so that the panel hangs plumb.
  - ⑤ You can now install your door pulls and other door hardware.
- ⚠ Installation of bottom guide is mandatory. Door panel has to be engaged by bottom guide along its entire travel. Door has to be installed plumb.



Not following the above instructions can cause a hazardous condition.

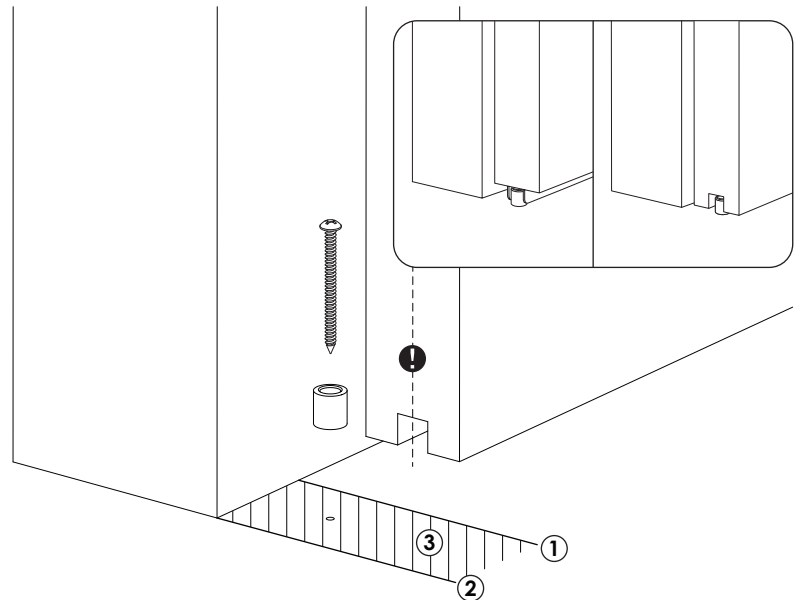

## 20. POSITION DOOR STOPS

- 1 With the doors in the desired closed position, slide the door stop so that it touches the trolley stop of the trailing trolley. Tighten the door stop in place to 110 inch-lbs.
- 2 Repeat with the doors in the open position, sliding the door stop so that it touches the trolley stop of the leading trolley.
- 3 Verify that the bottom guide posts are properly engaged in the fully open and fully closed positions.

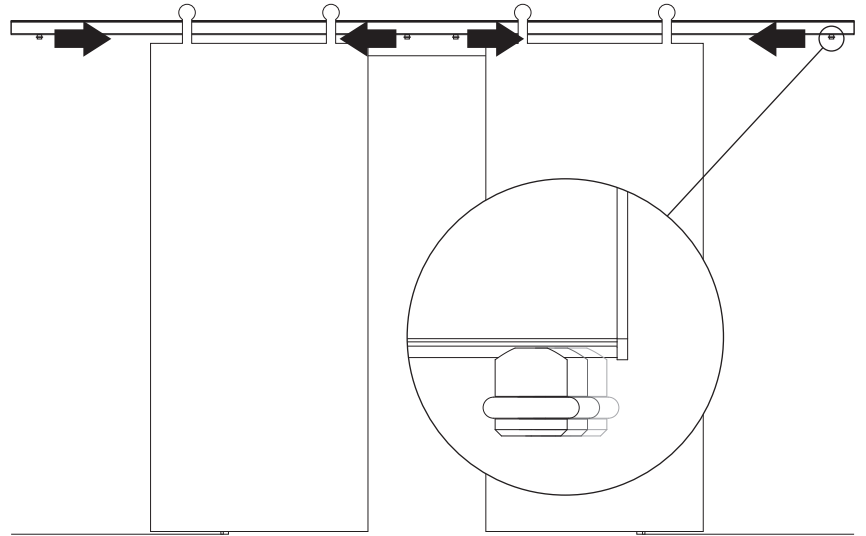

## 21. OPTIONAL STEP - INSTALL DOOR BOTTOM STOP

- 1 Recommended for heavy and high-use door panels.
- 2 With the door in the desired closed position, install the door bottom stop so that it touches the trailing edge of the door panel.
- 3 Repeat with the door in the open position, installing the door bottom stop so that it touches the leading edge of the door panel.

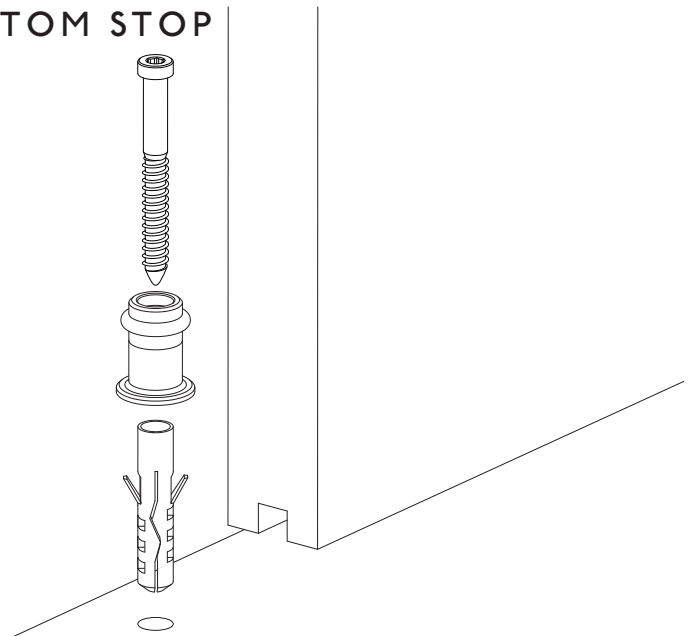

## 22. PRODUCT CARE

### Common Parts

Wheels (bearings) should occasionally be lubricated with bearing oil (e.g. SHC 630 Synthetic Gear and Bearing Oil by Exxon Mobil Corp: [www.mobil.com](http://www.mobil.com)).

### Brushed Stainless

To clean any time after installation, use a non-abrasive lint free cloth or sponge and household glass cleaner. (Remember to test an inconspicuous area prior to cleaning hardware.) Do not use steel wool, or a Scotch Brite pad, as it can scratch the product.

### Black Stainless

To enhance the depth and shine of the finish, periodically apply a thin coating of petroleum jelly with a clean cloth, buff clean and dry. Do not use steel wool, or a Scotch Brite pad, as it can scratch the product.

Product may be covered by pending and awarded U.S. patents. For more information visit [www.krownlab.com](http://www.krownlab.com)