

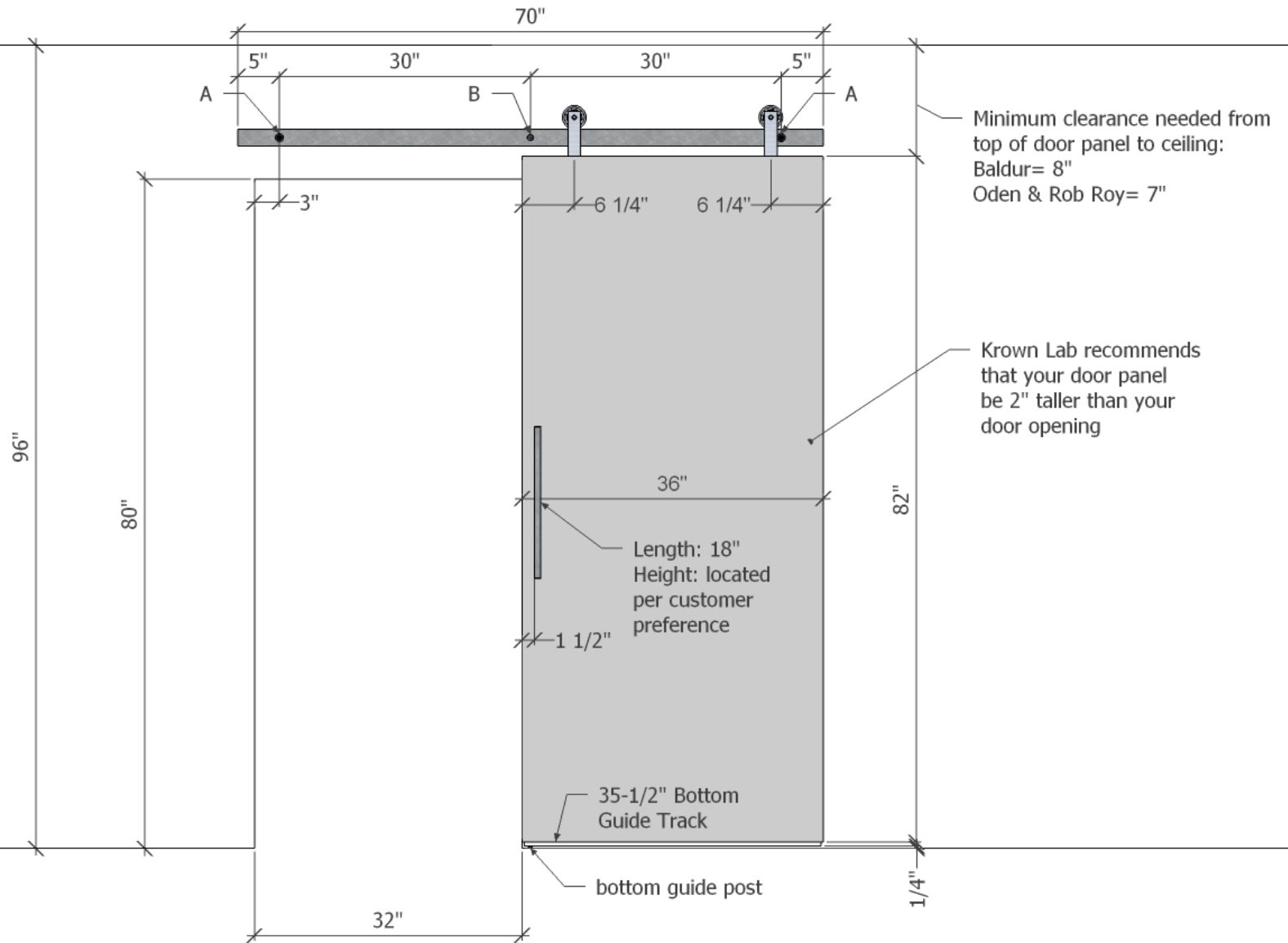

ROB ROY series custom drawing with 70" Track Configuration

Company Name (open)

KROWN LAB



Sales Order #: XXXX
 Date: XX.XX.XX
 Drawn by: michaelangelo

Hole Spec:
 A = 25/64" through hole (bumper)
 B = 9/16" front hole, 25/64" back hole

* Krown Lab system limits, information not provided by customer.

Track#	Qty.	Length	Finish	Panel weight	Panel depth
1	1	70"	LB SS	<150 lbs*	1-1/2" to 3" *

ROB ROY series custom drawing with 70" Track Configuration

Company Name (closed)



KROWN LAB

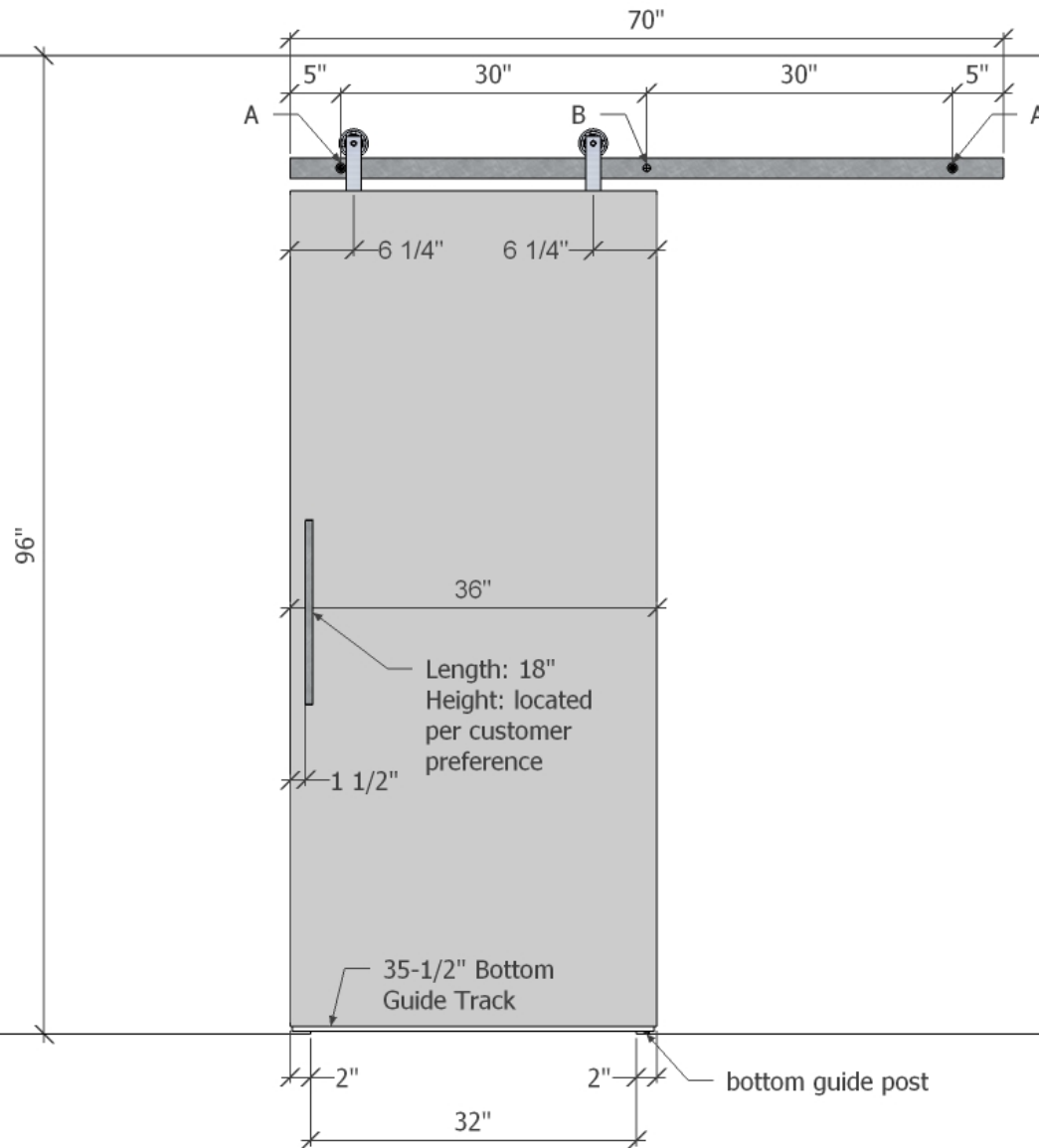

Sales Order #: XXXX
 Date: XX.XX.XX
 Drawn by: michaelangelo

Hole Spec:
 A = 25/64" through hole (bumper)
 B = 9/16" front hole, 25/64" back hole
 * Krown Lab system limits, information not provided by customer.

Track#	Qty.	Length	Finish	Panel weight	Panel depth
1	1	70"	LB SS	<150 lbs*	1-1/2" to 3" *

ROB ROY series custom drawing with 70" Track Configuration

Company Name (track drill pattern)



KROWN LAB

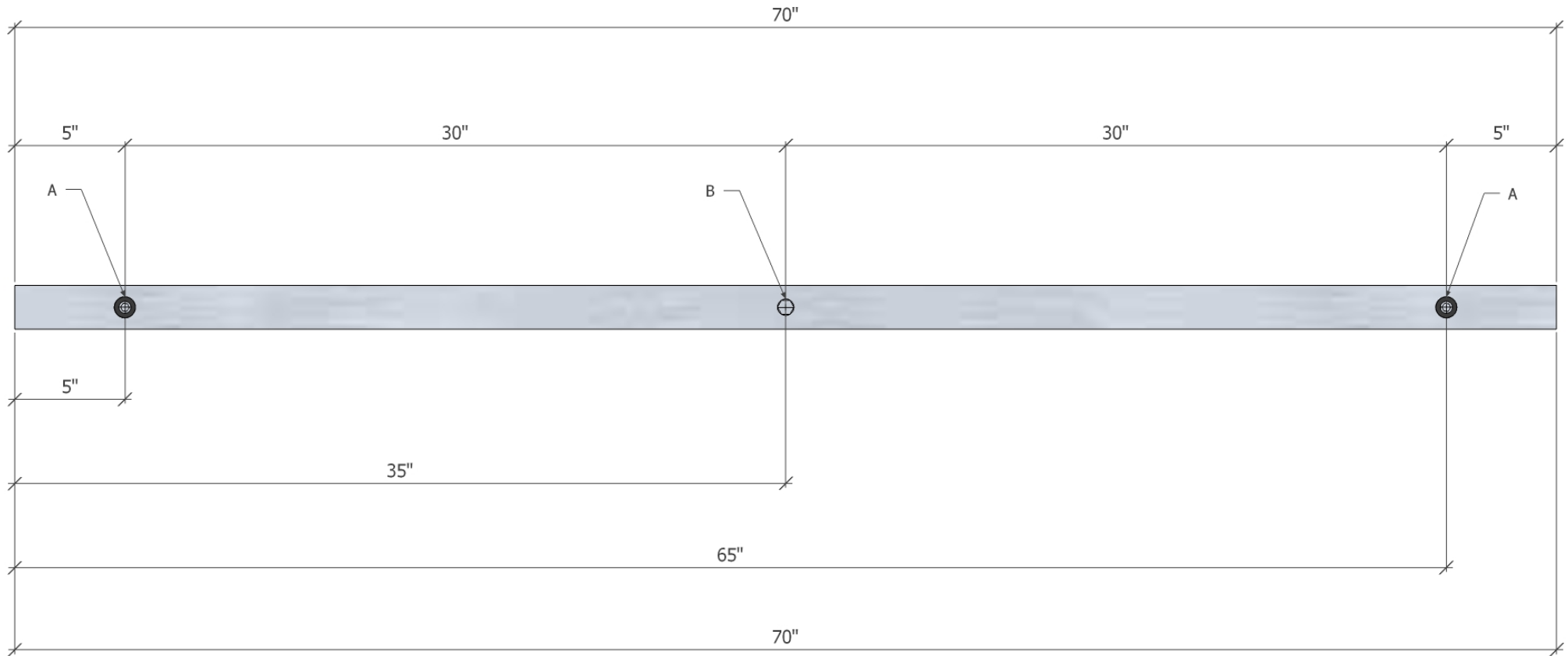

Sales Order #: XXXX
 Date: XX.XX.XX
 Drawn by: michaelangelo

Hole Spec:

A = 25/64" through hole (bumper)
 B = 9/16" front hole, 25/64" back hole

* Krown Lab system limits, information not provided by customer.

Track#	Qty.	Length	Finish	Panel weight	Panel depth
1	1	70"	LB SS	<150 lbs*	1-1/2" to 3" *