

DOCUMENT: PRODUCT SPECIFICATIONS	DOOR APPLICATION: SINGLE, BI-PARTING, BYPASSING	DRAWING SCALE: 1'-0" = 1'-0" (1:1)	KROWNLAB 2351 NW York St. Portland, OR 97210 +1 503 292 6998 www.krownlab.com support@krownlab.com
SYSTEM: EBBA DOOR PULL	PANEL THICKNESS: 3/8" TO 3/4"	UNITS: INCHES	
MOUNTING STYLE: GLASS	MAXIMUM WEIGHT: TROLLEY SYSTEM OR TRACK CONFIGURATION DEPENDENT	DATE: 12/13/2018	

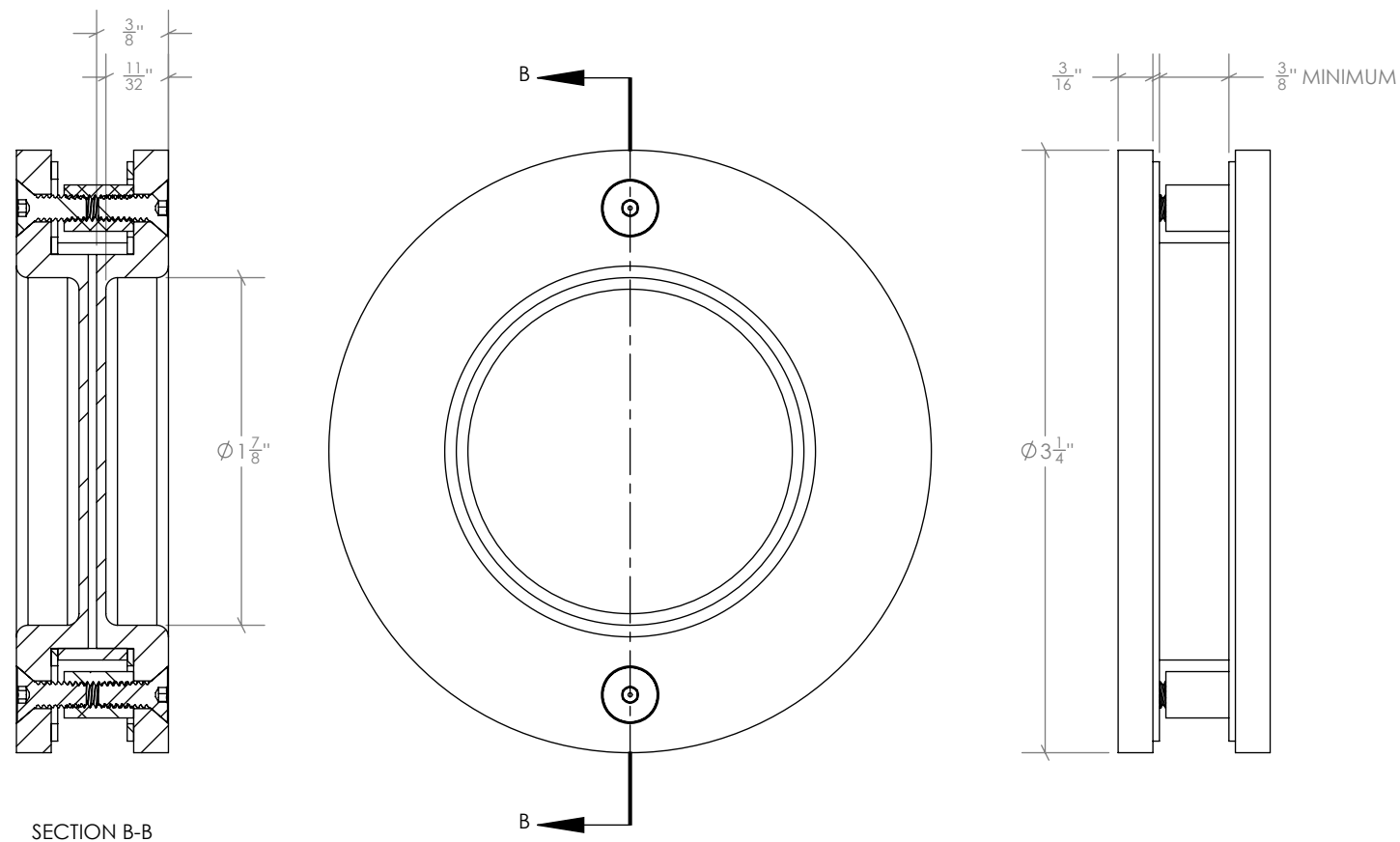

GLASS PANELS MUST BE FLAT POLISHED AND HAVE A 1MM CHAMFER ON ALL EDGES.
 ALL HOLES MUST BE DRILLED OR CNC MACHINED WITH STRAIGHT WALLS AND SEAMED EDGES. DO NOT WATER-JET - NO TAPERED HOLES.
 ALL TEMPERED GLASS IS SUBJECT TO EXPERIENCE SPONTANIOUS BREAKAGE. IT IS THE BUYERS RESPONSIBILITY TO DETERMINE AND APPROVE GLASS SPECIFICATION(S) SUITABLE TO MEET ALL FACTORS RELEVANT TO THEIR PARTICULAR USE OR APPLICATION IN CONJUNCTION WITH ALL KROWN LAB, INC.'S PRODUCTS.
 REFERENCE ASTM C1048, 7.9.5

