

DOCUMENT:	PRODUCT SPECIFICATIONS - PREMIUM DOOR STOP	DOOR APPLICATION:	SINGLE*, BI-PARTING*, BYPASSING*	DRAWING SCALE:	3/4" = 1'-0" (1:16)	KROWNLAB 2351 NW York St. Portland, OR 97210 +1 503 292 6998 www.krownlab.com support@krownlab.com	 <small>PDX - ORE</small>
SYSTEM:	TRU-LEVEL™ TRACK	PANEL THICKNESS:	TROLLEY SYSTEM OR TRACK CONFIGURATION DEPENDENT	UNITS:	INCHES		
MOUNTING STYLE:	TOP MOUNT, FACE MOUNT, GLASS MOUNT	MAXIMUM WEIGHT:	TROLLEY SYSTEM OR TRACK CONFIGURATION DEPENDENT	DATE:	10/9/2018		

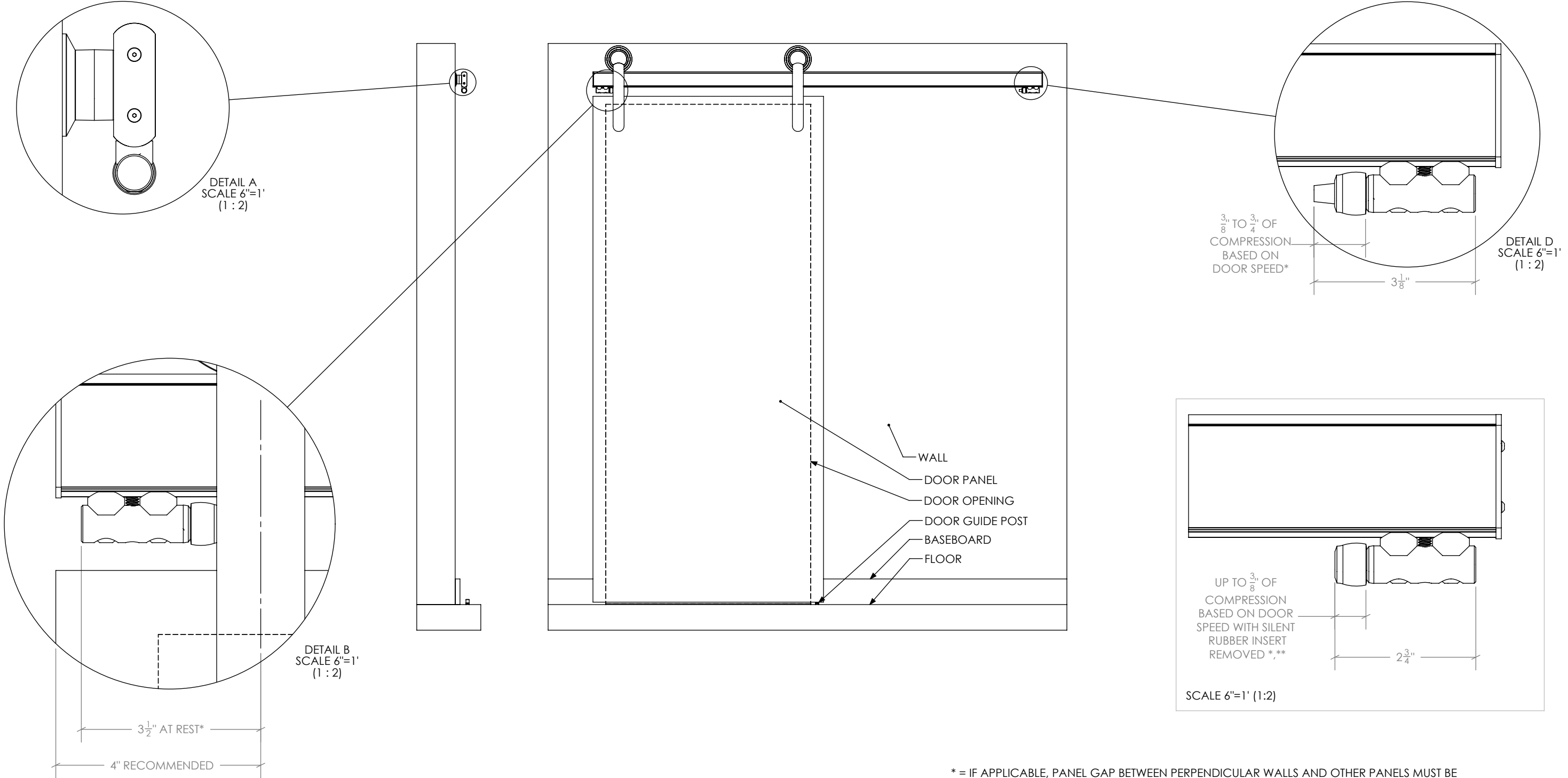

\* = IF APPLICABLE, PANEL GAP BETWEEN PERPENDICULAR WALLS AND OTHER PANELS MUST BE INCREASED TO AVOID COLLISION. DOOR TRAVEL INCREASES BASED ON SPEED AND COMPRESSION OF PREMIUM DOOR STOP.

\*\* = REMOVING SILENT RUBBER INSERT WILL REMOVE THE SILENT FEATURE, BUT MAY BE A NECESSARY ADJUSTMENT TO REDUCE POSSIBLE EXTRA DOOR TRAVEL. THE ENERGY ABSORBING FEATURE OF THE PREMIUM DOOR STOP WILL REMAIN IN THIS CONFIGURATION.